

Test Report issued under the responsibility of:

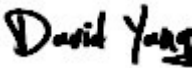

TEST REPORT IEC 62841-1 Electric Motor-Operated Hand-Held Tools, Transportable Tools and Lawn and Garden Machinery – Safety	
Report Number.....	6141986.51QS
Date of issue.....	2022.12.23
Total number of pages	20
Name of Testing Laboratory preparing the Report	DEKRA Testing and Certification (Shanghai) Ltd. 3F #250 Jiangchangan Road Building 16, Headquarter Economy Park Shibe Hi-Tech Park, Jing'an District Shanghai 200436 CHINA
Applicant's name	LEE YEONG INDUSTRIAL CO., LTD.
Address.....	No.2, Kejia Rd., Douliu City, Yunlin County 64057, Taiwan
Test specification:	
Standard	Sub-clause 18.8 of IEC 62841-1: 2014; EN 62841-1:2015 IEC 62841-2-3:2020 EN IEC 62841-2-3:2021+A11:2021
Test procedure	SCF assessment
Non-standard test method	N/A
TRF template used.....	IECEE OD-2020-F1:2020, Ed.1.3
Test Report Form No.	IEC 62841_SCF_Assessment_1A
Test Report Form(s) Originator	DEKRA Testing and Certification (Shanghai) Ltd.
Master TRF	2022-02-23
General disclaimer:	
<p>This document may only be reproduced in its entirety and without any change.</p> <p>DEKRA Testing and Certification and/or its associated companies disclaim liability for any direct, indirect, consequential or incidental damages that may result from the use of the information or data, or from the inability to use the information or data.</p> <p>This Test Report contains the test results related to the sample(s) test and document(s).</p> <p>The tests results cannot be used for any statement related to the quality of the equipment from running production.</p>	

Test item description	Electric Drywall Sander(Mains powered)	
Trade Mark	AGP	
Manufacturer	LEE YEONG INDUSTRIAL CO., LTD. No.2, Kejia Rd., Douliu City, Yunlin County 64057, Taiwan	
Model/Type reference	Detail see "General product information and other remarks".	
Ratings	110-120 Vac; 550 W 220-240 Vac; 550 W	
Software version	GS225MSWV2_V01A	
Hardware version	LY910M-V2_V03	
(PCB)		
Responsible EMC Testing Laboratory (as applicable), testing procedure and testing location(s):		
CB Testing Laboratory:		
Testing location/ address	DEKRA Testing and Certification (Shanghai) Ltd. 3F #250 Jiangchangsan Road Building 16, Headquarter Economy Park Shibe Hi-Tech Park, Jing'an District Shanghai 200436 CHINA	
Tested by (name, function, signature)	Xueyan Zhao	
Approved by (name, function, signature)	David Yang	

Test item particulars: -	
Possible test case verdicts:	
- test case does not apply to the test object.....: N/A	
- test object does meet the requirement.....: P (Pass)	
- test object does not meet the requirement.....: F (Fail)	
Testing:	
Date of receipt of test item: 2022.07.17	
Date (s) of performance of tests: 2022.07.17-2022.08.17	
General remarks:	
<p>"(See Enclosure #)" refers to additional information appended to the report. "(See appended table)" refers to a table appended to the report.</p> <p>Throughout this report a <input checked="" type="checkbox"/> comma / <input type="checkbox"/> point is used as the decimal separator.</p> <p>Required performance levels for applicable safety critical functions are specified by the relevant part of IEC 62841-2, IEC 62841-3 or IEC 62841-4. Typical safety critical functions are indicated in table 18.8.1A.</p> <p>Software used in circuits of programmable devices whose failure would create loss of safety critical function, complied with requirements as in table 18.8.1B according to IEC 60730-1:2010.</p> <p>If safety critical functions are evaluated by using the fault conditions of 18.6.1 and will not result in a loss of any safety critical function or shall place and maintain the tool into a safe state, Software assessment is not applicable. See table 18.6.1 while the fault condition is present.</p>	
Manufacturer's Declaration per sub-clause 4.2.5 of IEC 60300-2-1:	
The application for obtaining a CB Test Certificate includes more than one factory location and a declaration from the Manufacturer stating that the sample(s) submitted for evaluation is (are) representative of the products from each factory has been provided	<input type="checkbox"/> Yes <input checked="" type="checkbox"/> Not applicable
When differences exist, they shall be identified in the General product information section.	
Name and address of factory (ies): LEE YEONG INDUSTRIAL CO., LTD. NO.2, KEJIA RD, DOULIU CITY, YUNLIN COUNGY, TAIWAN	

General product information and other remarks:





Besides the length of handle and connection of head, the construction and components are all same with these samples.

See details as below:

Model (long-reach type)	Model (compact type)	Rated voltage
GS9FE, PI2001, 40700 (DRS2250), MAP-GS9FE, POG225, PB225, WS230F, S9F, DWS9F	GS9FSE, PI2001	110-120 V or 220-240 V
GS9UE, DW20, Miro 955, Miro 955, FDW-550-110, FDW-550- 240, WS230E, S9E, DWS9E	GS9USE, DW10, Miro 955-S	110-120 V or 220-240 V
GS9GE, 62 50 00	GS9GSE, 62 55 00	110-120 V or 220-240 V
FM225U, DWS225L, LHS 225 PRO, LPC97S, FM225U, DWS9	FM225US	220-240 V
GS225U, P1500	GS225US	220-240 V
GS225G, AG700	GS225GS, AG799	220-240 V
GS9U, DYNO 550, MAXPRO 500, PS-1000, TESLER, WS230U, S9U, DWS9U	GS9US,MAXPRO 250	110-120 V or 220-240 V
GS9G	GS9GS	110-120 V or 220-240 V
DWS225	DWS225S	220-240 V

Description of Safety Critical Functions (SCF), if any:

1. Prevent exceeding thermal limits as in Clause 18
2. Restart prevention
3. Prevent self-resetting

18.8	Electronic circuits providing safety critical functions (SCF)		—
18.8.1	Electronic circuits providing SCF are reliable and not susceptible to loss of SCF due to electro-magnetic environmental stresses	See documents:  GS9-1_CS_20220902  GS9-1_Dips_20220902  GS9-1_EFT_20220902  GS9-1_ESD_20220902  GS9-1_Surge_20220902	P
	No SCF lost after tests of 18.8.2 to 18.8.6 for circuits with no internal clock frequency or oscillator frequency > 15 MHz	> 15 MHz (4 MHz)	N/A
	No SCF lost after tests of 18.8.2 to 18.8.7 for other electronic circuits	For Mains tools: No SCF lost after tests of 18.8.2 to 18.8.7.	P
	Test voltage was rated voltage or the mean value of the rated voltage range..... :	110-120 Vac; 220-240 Vac	P
	Difference between upper and lower limit of rated voltage range > 20 % of its mean value, test at both upper and lower limits of the rated voltage range .. :		N/A
	After evaluation using 18.6.1, no loss of any SCF or tool in a safe state under any present fault condition.		N/A
	Concept of 18.6.1 not appropriate, reliability evaluated using ISO 13849-1.	1.Prevent exceeding thermal limits as in Clause 18 2. Restart prevention 3. Prevent self-resetting	P
	Required performance levels	See Table 18.8.1A	P
	If only MTTF _d is applied to achieve the required PL: MTTF _d is 5/20/50 years for PL = a/b/c		P
	Software used in circuits of programmable devices whose failure would create loss of safety critical function, complied with software class B requirements as in H.11.12.3 of IEC 60730-1:2010	See Table 18.8.1B	P
	In the case where software class B is realized by single channel with periodic self-test, an acceptable period is regarded as either after each activation of the power switch or a maximum of 5 min.		P
	Class B realized by single channel, periodic self-test either after each activation of the power switch or at least every maximum 5 min		P
	H.11.12.3.4.1 applicable for SCF with a PL ≥ c		P
18.8.2	Electrostatic discharges as in IEC 61000-4-2:2008 applied to tool, test level 4 used for air discharge and test level 3 for contact discharge, ten / ten discharges having a positive / negative polarity applied		P

18.8.3	Fast transient bursts as in IEC 61000-4-4:2012 applied to tool, test level 3 used. Repetition frequency 5 kHz for 2 min / 2 min with a positive / negative polarity		P
18.8.4	Voltage surges as in IEC 61000-4-5:2005 applied to power supply terminals, five positive impulses and five negative impulses applied at the selected points		P
	Test level 3 applied for line-to-line coupling mode, a generator with 2 Ω source impedance being		P
	Test level 4 applied for line-to-earth coupling mode, a generator with 12 Ω source impedance being		P
	Tools has surge arresters incorporating spark gaps, test was repeated at 95 % of the flashover voltage		P
18.8.5	Injected currents as in IEC 61000-4-6:2008 applied to tool, test level 3 applicable, all frequencies between 0,15 MHz to 230 MHz covered		P
18.8.6	Class 3 voltage dips and interruptions in accordance with IEC 61000-4-11:2004 applied to tool		P
	Values of Tables 1 and 2 of IEC 61000-4-11:2004 were applied at zero crossing of the supply voltage		P
18.8.7	Radiated fields in accordance with IEC 61000-4-3:2010 applied to tool, test level 3 applicable		N/A
	Frequency ranges 80 MHz to 1 000 MHz tested		N/A

18.6.1	TABLE: Fault Condition Tests		
	Ambient temperature (°C)	20°	—
	Fuse-link Current (A)	—	—

The test method is to open or short circuit the safety critical functional related electronic components, the test results all passed (normal operation with no loss of SCF or no operation/ safe state).

18.8.1A	TABLE: Performance levels of Safety Critical Functions			
Type and purpose of SCF	Min. PL determined based on: ^{1,2}	Min. PL	Actual PL	
Prevent exceeding thermal limits as in Clause 18	a	a	c	
Restart prevention	b	b	c	
Prevent self-resetting	c	c	c	
Supplementary Information: ¹ Relevant part of IEC 62841-2, IEC 62841-3 or IEC 62841-4 or; if no such part existent, ISO 13849-1 using Annex E as a guide ² For safety critical functions not listed in Table 4 of IEC 62841-1 and provided by electronic circuits, PL values were determined using the methods of ISO 13849-1.				

18.8.1B	TABLE: Software in Safety Critical Functions		—
H.11.12.3 from IEC 60730-1:2010			
H.11.12.3	Measures to avoid errors		—
H.11.12.3.1	For controls with software Class B or C the V-model for the software life cycle was applied		P
	Measures used for software class C are inherently acceptable for software class B		N/A
	Other methods applied if they incorporate disciplined and structured processes including design and test phases		N/A
H.11.12.3.2	Specification		—
H.11.12.3.2.1	Software safety requirements		—
H.11.12.3.2.1.1	The specification of the software safety requirements includes:		—
	<ul style="list-style-type: none"> • A description of each safety related function to be implemented, including its response time(s): <ul style="list-style-type: none"> ○ functions related to the application including their related software classes ○ functions related to the detection, annunciation and management of software or hardware faults 		P
	<ul style="list-style-type: none"> • A description of interfaces between software and hardware 		P
	<ul style="list-style-type: none"> • A description of interfaces between any safety and non-safety related functions 		P
H.11.12.3.2.2	Software architecture		—
H.11.12.3.2.2.1	The description of software architecture shall include the following aspects:		—
	<ul style="list-style-type: none"> • Techniques and measures to control software faults/errors (refer to H.11.12.2) 		P
	<ul style="list-style-type: none"> • Interactions between hardware and software 		P
	<ul style="list-style-type: none"> • Partitioning into modules and their allocation to the specified safety functions 		P
	<ul style="list-style-type: none"> • Hierarchy and call structure of the modules (control flow) 		P
	<ul style="list-style-type: none"> • Interrupt handling 		P
	<ul style="list-style-type: none"> • Data flow and restrictions on data access 		P
	<ul style="list-style-type: none"> • Architecture and storage of data 		P
	<ul style="list-style-type: none"> • Time based dependencies of sequences and data 		P

H.11.12.3.2.2	The architecture specification was verified against the specification of the software safety requirements by static analysis. Acceptable methods are:	—
	• Control flow analysis	P
	• Data flow analysis	P
	• Walk-throughs / design reviews	P
H.11.12.3.2.3.1	Based on the architecture design, software is suitably refined into modules. Software module design and coding are implemented in a way that is traceable to the software architecture and requirements	P
H.11.12.3.2.3.2	Software code is structured	P
H.11.12.3.2.3.3	Coded software is verified against the module specification, and the module specification is verified against the architecture specification by static analysis	P
H.11.12.3.2.4	Design and coding standards	—
	Program design and coding standards is consequently used during software design and maintenance	P
	Coding standards specify programming practice, proscribe unsafe language features, and specify procedures for source code documentation as well as for data naming conventions	P
H.11.12.3.3	Testing	—
H.11.12.3.3.1	Module design (software system design, software module design and coding)	—
H.11.12.3.3.1.1	A test concept with suitable test cases is defined based on the module design specification.	P
H.11.12.3.3.1.2	Each software module is tested as specified within the test concept	P
H.11.12.3.3.1.3	Test cases, test data and test results are documented	P
H.11.12.3.3.1.4	Code verification of a software module by static means includes such techniques as software inspections, walk-throughs, static analysis and formal proof	P
	Code verification of a software module by dynamic means includes functional testing, white-box testing and statistical testing	P
H.11.12.3.3.2	Software integration testing	P
H.11.12.3.3.2.1	A test concept with suitable test cases is defined based on the architecture design specification	P

H.11.12.3.3.2.2	The software is tested as specified within the test concept		P
H.11.12.3.3.2.3	Test cases, test data and test results are documented		P
H.11.12.3.3.3	Software validation		—
H.11.12.3.3.3.1	A validation concept with suitable test cases is defined based on the software safety requirements specification		P
H.11.12.3.3.3.2	The software is validated with reference to the requirements of the software safety requirements specification as specified within the validation concept.		P
	The software is exercised by simulation or stimulation of:		P
	• input signals present during normal operation		P
	• anticipated occurrences		P
	• undesired conditions requiring system action		P
H.11.12.3.3.3.4	Test cases, test data and test results are documented		P
H.11.12.3.4	Other Items		—
H.11.12.3.4.1	Tools, programming languages are assumed to be suitable if they comply with "increased confidence from use" according to IEC 61508-7, C.4.4	Only applicable for SCF with $PL \geq c$	P
H.11.12.3.4.2	Management of software versions: All versions are uniquely identified for traceability		P
H.11.12.3.4.3	Software modification		—
H.11.12.3.4.3.1	Software modifications are based on a modification request which details the following:		—
	• the hazards which may be affected		N/A
	• the proposed change		N/A
	• the reasons for change		N/A
H.11.12.3.4.3.2	An analysis is carried out to determine the impact of the proposed modification on functional safety.		N/A
H.11.12.3.4.3.3	A detailed specification for the modification is generated including the necessary activities for verification and validation, such as a definition of suitable test cases		N/A
H.11.12.3.4.3.4	The modification are carried out as planned		N/A
H.11.12.3.4.3.5	The assessment of the modification is carried out based on the specified verification and validation activities. This may include:		N/A

	<ul style="list-style-type: none"> • a reverification of changed software modules 		N/A
	<ul style="list-style-type: none"> • a reverification of affected software modules 		N/A
	<ul style="list-style-type: none"> • a revalidation of the complete system 		N/A
H.11.12.3. 4.3.6	All details of modification activities are documented		N/A
H.11.12.3. 5	For class C control functions: One of the combinations (a–p) of analytical measures given in the columns of table H.9 is used during hardware development	Measures to avoid errors for class C not required	N/A

Annex 1 Description of Test Object

The product under evaluation is the safety critical functions of models manufactured by LEE YEONG INDUSTRIAL CO., LTD.

The following safety critical functions are evaluated in this report.

SCF1: Prevent exceeding thermal limits as in Clause 18

Over current protective function is provided to meet this requirement. According to the above table 18.8.1A, PLr = a.

SCF2: Restart prevention

The power off protection function is realized by IC 12F675 and hardware circuit, According to table 1 of IEC/EN 62841-2-3, PLr = b.

SCF3: Prevent self-resetting

The tool has protective circuits that switch off the tool and Monitoring switch status. So, a protective circuit is provided to meet this requirement. According to above table 1, PLr = c.

Annex 2 Achieved Performance Level--Calculation of MTTFd

Component	Reliability Reference	No.	Units n	MTTFd Typical years	n/MTTFd Typical 1/year
Resistor-Carbon Film	ISO 13849	R1	1	114155	0.0000088
Capacitor-Ceramics	ISO 13849	C2, C2A, C6, CS1, CS9, CV1, CVP	7	45662	0.0001533
Standard, no power	ISO 13849	XC1	1	114115	0.0000088
Aluminium electrolytic	ISO 13849	C1	1	45662	0.0000219
Rectifier diodes	ISO 13849	D1 \ DVP	2	228311	0.0000088
Zener diode Ptot < 1 W	ISO 13849	ZD1	1	228311	0.0000044
Low frequency inductors	ISO 13849	CH1	1	45662	0.0000219
MCU	supplier	IC1	1	8799	0.1000000
Triac	ISO 13849	TR1	1	3044	0.0003285
MTTFd (years)Total	1492.697936				

Table: MTTFd 1

Component	Reliability Reference	No.	Units n	MTTFd Typical years	n/MTTFd Typical 1/year
Resistor-Carbon Film	ISO 13849	R1	1	114155	0.0000088
Capacitor-Ceramics	ISO 13849	C2, C2A, C6, CS1, CS9, CV1, CVP	7	45662	0.0001533
Standard, no power	ISO 13849	XC1	1	114115	0.0000088
Aluminium electrolytic	ISO 13849	C1	1	45662	0.0000219
Rectifier diodes	ISO 13849	D1、DVP	2	228311	0.0000088
Zener diode Ptot < 1 W	ISO 13849	ZD1	1	228311	0.0000044
Low frequency inductors	ISO 13849	CH1	1	45662	0.0000219
MCU	supplier	IC1	1	10	0.1000000
Triac	ISO 13849	TR1	1	3044	0.0003285
MTTFd (years)Total					1492.697936

Table: MTTFd 2

The calculated overall MTTF_d values are over **50 years**. According to Cl. 4.6 of EN ISO 13849-1, the circuitry design can meet this requirement.

Annex 3 Description of Safety Software

System Description

System diagram

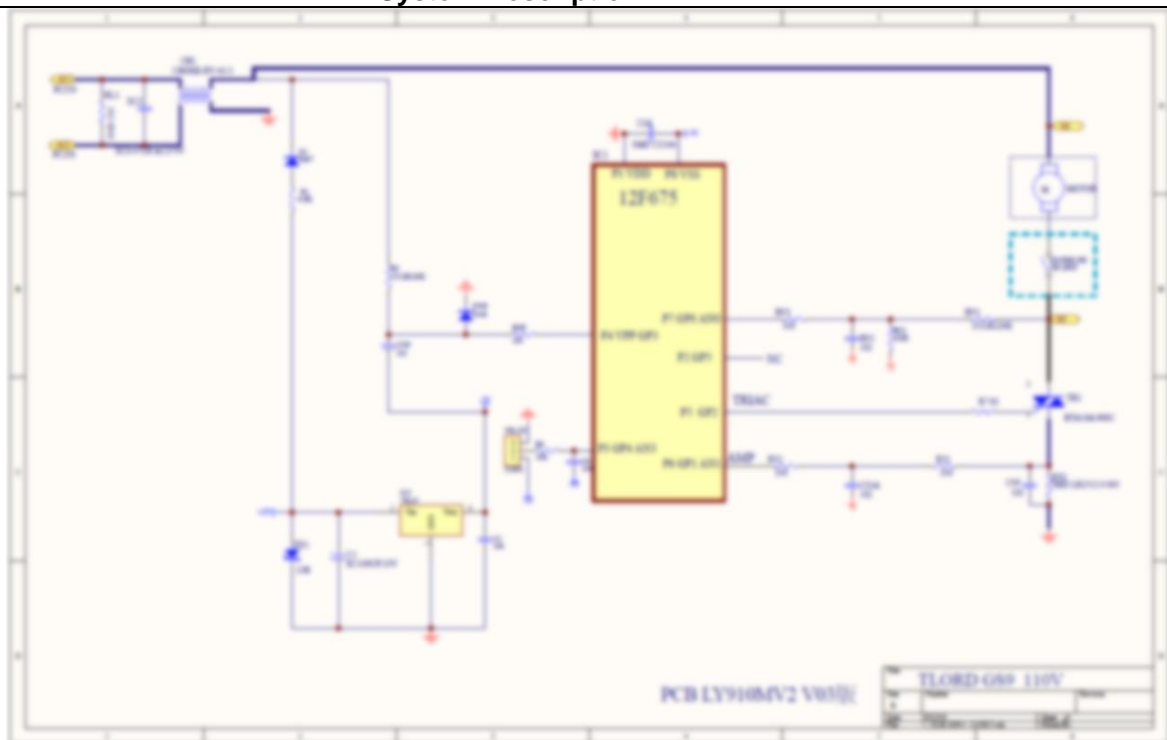

Figure 1: Hardware Structure Diagram

Description of SCF- Prevent exceeding thermal limits as in Clause 18:

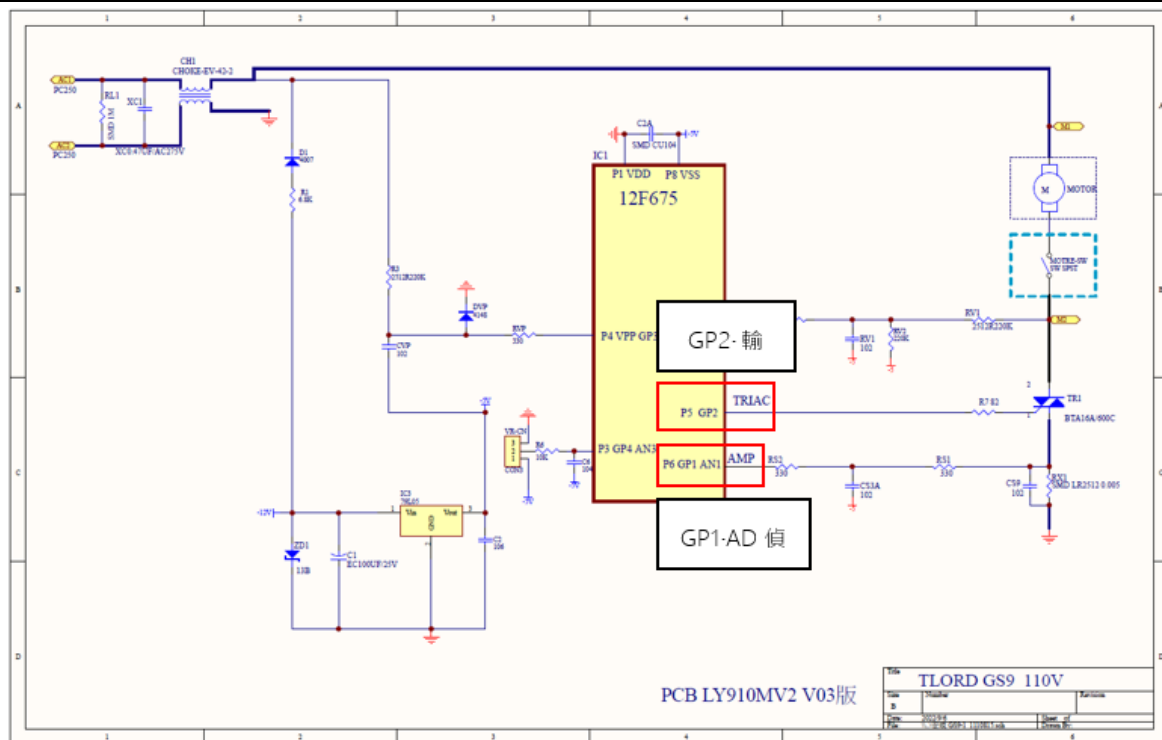
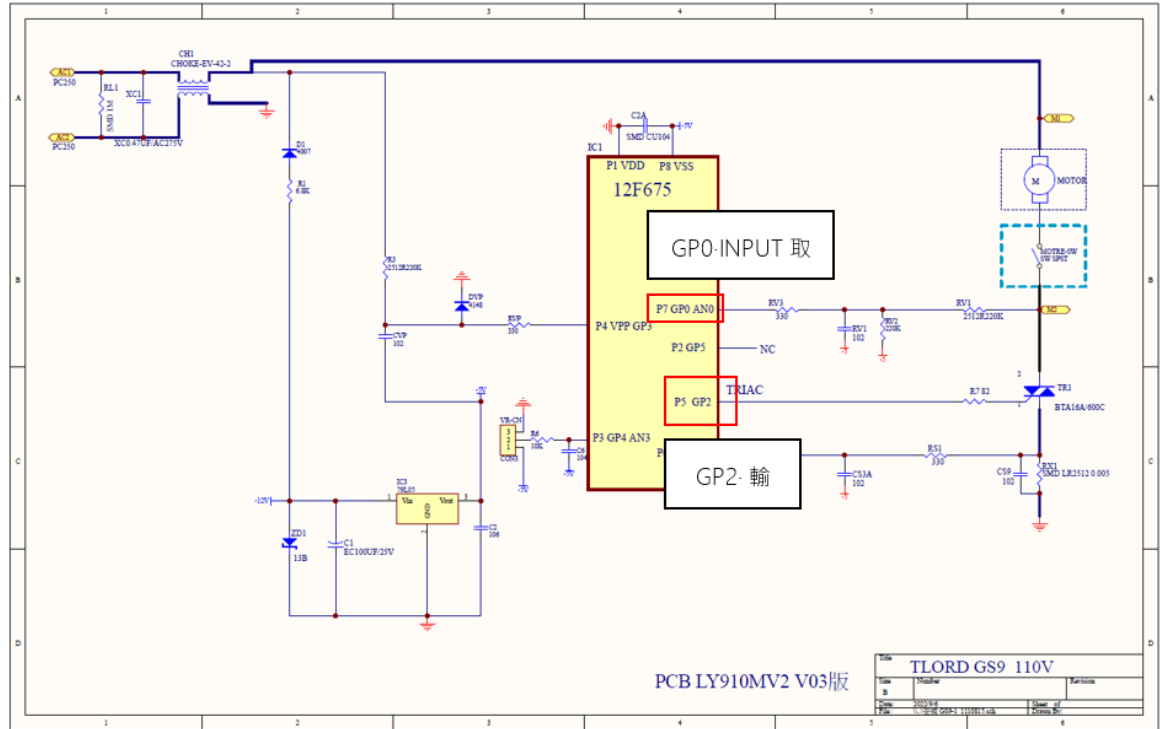

Figure 2: Schematic of Overcurrent

Overcurrent protection:

IC 12F675 and hardware circuit implement the overcurrent protection, GP2/Pin P5 send turn on/off signal, drive the TR1, the current will be sampled by GP1/Pin P6, if the current over the threshold value, MCU will shut the output signal.

Description of SCF- Restart prevention:



Power off protection:

When the power is input, if the switch is in the ON position, the protection mechanism will be started, P7 GP0 will get current signal and GP2 will have no output signal. The motor will be locked and not started. After that, the switch will be switched to the OFF position and then enter the use mode.

When input power, if the switch in the OFF position, directly into the use mode.

Establishment time :50ms

Description of SCF- Prevent self-resetting:

Flowchart:

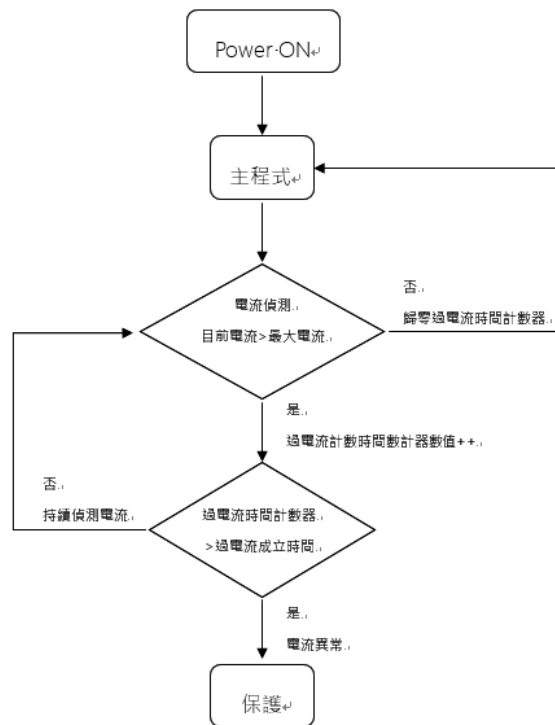

When the tool enter protection state, IC 12F675 will enter error flag, only reset the switch, the IC will clear the flag.

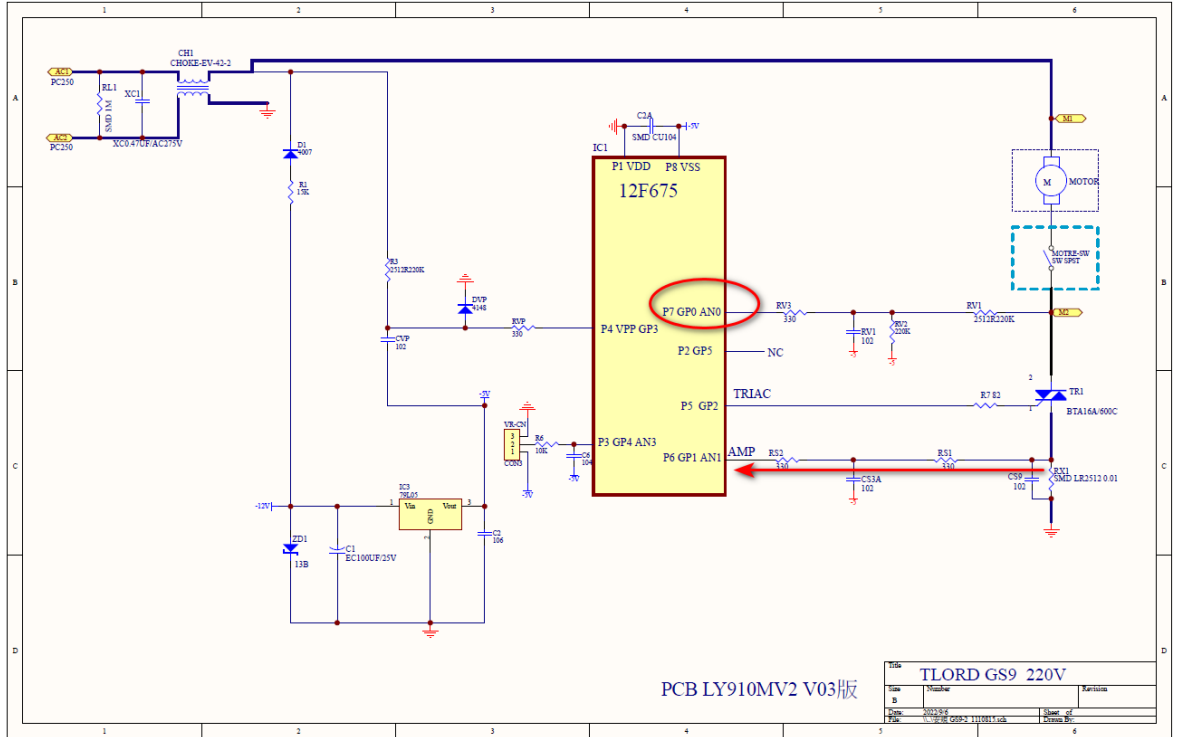

Software Architecture Design

Software Architecture

Firstly, system initialization is performed, including initializing MCU peripheral, clear watchdog, etc. Then, sampling is enabled. The tool starts working only when the switch is determined pressed on, otherwise, it is kept not working. When the system works in the normal working state, motor current are periodically checked. If over current is judged, over current protective function is executed, the tool is stopped working. If the switch is determined released, the tool is stopped.

Flowchart:

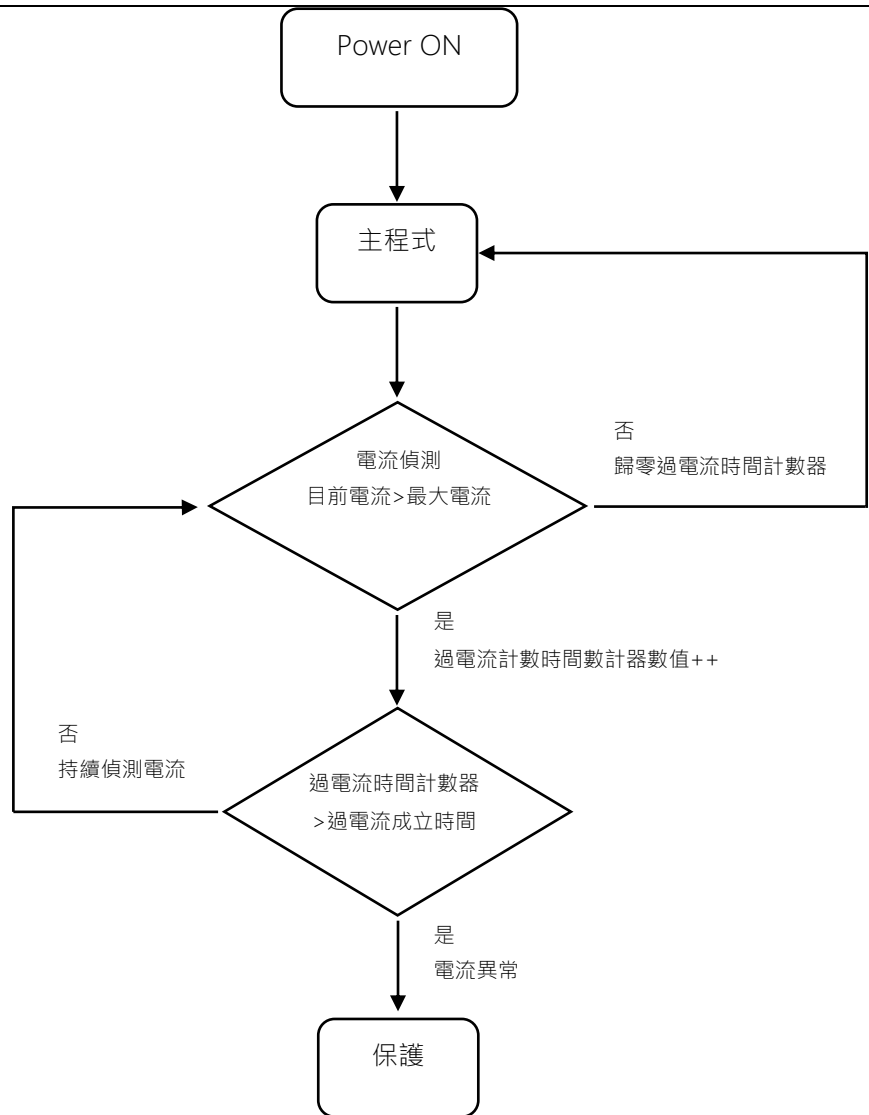

保護機制:

1. 不觸發 TRIAC，馬達停止運轉。

Figure 3: Software Architecture

The Overcurrent threshold value:

Current overload point 1: 2A is established for 3 consecutive seconds.

Note: No current is detected within 2 seconds of motor operation.

Architecture Verification	<p>A control flow analysis is used as the static analysis approach to verify the architecture against the software safety requirements.</p> <p>The following aspects of the drop prevention function have been taken into account:</p> <ul style="list-style-type: none"> - Proper flow of the code - Code structure analysis - Data processing <p>The code must meet the following criteria:</p> <ol style="list-style-type: none"> 1. For the control flow of the code: <ul style="list-style-type: none"> - Meet the predefined design in terms of code sequence - No uncontrolled loops - No unused code and variables/objects - No unexpected code (paths/flow) 2. For code structure: <ul style="list-style-type: none"> - No unexpected/unintended outputs - No unexpected actions/responses 3. For data processing: <ul style="list-style-type: none"> - All safety related variables must be in a certain range - All safety related variables must be initialized before using - All safety related variables must be correctly used after definition (to avoid variables unused or improperly used) <p>After verification, all the code meets these criteria. The software developed has the same architecture design as the software specification, see manufacturer's document "GS9-2_Overcurrent protection work description_20220905".</p>
Module Design and Coding	
Module Design and Coding Techniques	<p>Following techniques are used to assure the modular design and coding of the software:</p> <ul style="list-style-type: none"> - Size of functional module is limited to be as small as possible - Each software module refers to a single object - Values get from ADC out of a certain range is illegal - Divide by zero situations is handled individually for each division - During initialization, RAM memory is erased (0 value) to assure a known value before executing of any code <p>Following techniques are used to keep the code structured:</p> <ul style="list-style-type: none"> - An internal coding standard is used - No dynamic variables used and no dynamic memory allocation involved - Interrupts are fixed at design level - Recursion is not used - No unconditional jump are used
Module Verification	<p>A control flow analysis is used as the static analysis approach to verify the module against the module techniques specification. After verification, all the code meets these criteria. The software module developed has the same architecture design as the software module specification, see manufacturer's document "GS9-2_Overcurrent protection work description_20220905".</p>
Validation	
Validation of SCF- Prevent exceeding thermal limits as in Clause 18:	<p>When the tool ran at overload, during and after the test, the tool did not exceed thermal limits. See manufacturer's document "GS9-2_Validation test_20220907".</p>
Validation of SCF- Restart prevention :	<p>The tool is locked on using the normal lock-on method, then the plug is disconnected from the mains and connected again. Neither during nor after the EMC test, the tool shall start operating. See manufacturer's document "GS9-2_Validation test_20220907".</p>

Validation of SCF- Prevent self-resetting:	The motor of the tool was blocked which caused the tool stopped during operation. The tool cannot restart until the trigger switch was released and then retriggered. See manufacturer's document "GS9-2_Validation test_20220907".
--	---

-----**END**-----