

DIAMOND CONCRETE SAWS

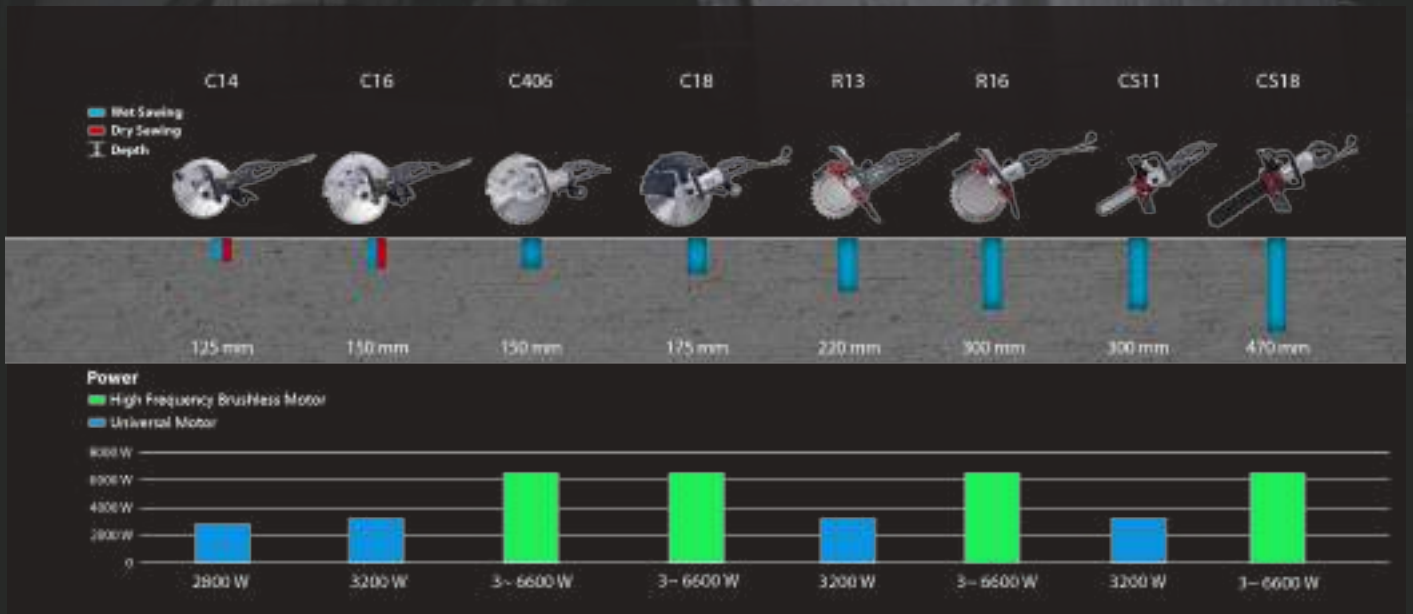

C14 CONCRETE SAW

355 mm (14") handheld wet or dry diamond saw with 3000 W motor for up to 125 mm depth of cut. Ideal for indoor cutting.



■ **Dry Cutting With Dust Skid (Optional)**

With spring-loaded suspension for ideal dust containment when dry cutting



Model	C14
Power Input	3000 W (230-240 V), 2800 W (220 V), 2300 W (110-120 V)
Voltage, Frequency	230-240 V~ 50-60 Hz, 220 V~ 50-60 Hz or 110-120 V~ 50-60 Hz
No Load Speed	4500 min ⁻¹
Linear speed with 14" blade	83.6 m/s (no load), 54.3 m/s (rated)
Blade Diameter	355 mm (14")
Arbor	25.4 mm (1")
Max. Cutting Depth	125 mm (5")
Soft Start & Overload Protection	With
Insulation Class	Class I with PRCD / GFCI
Dimensions (LxWxH)	611 x 245 x 280 mm
Weight	7.9 kg (17 lb) 8.3 kg (18 lb) with guide rollers
Characteristics / Certification	

Features

1. LED Indicator Indicates load conditions (electronic & thermal protection).
2. Integrated water feed system with fine adjustable flow and quick release coupling.
3. Tool-free detachable guide rollers for perpendicular cuts and reduced operator fatigue.
4. Tool-free detachable splash guard.
5. Tool-free blade guard angle adjustment. Handles designed for optimal control.
6. Hall Effect Switch is completely waterproof and dustproof.
7. Quick removable brush for slurry.
8. Externally accessible brushes.

Standard/ Optional Accessories See p. 23

C16 CONCRETE SAW

406 mm (16") handheld wet or dry diamond saw with 3200 W motor for up to 150 mm depth of cut. Ideal for indoor cutting.



■ **Dry Cutting With Dust Skid (Optional)**

With spring-loaded suspension for ideal dust containment when dry cutting



■ **Flush Cutting (Optional)**

Flush cutting details see p. 12



Model	C16
Power Input	3200 W (230-240 V), 3000 W (220 V), 2800 W (110-120 V)
Voltage, Frequency	230-240 V~ 50-60 Hz, 220 V~ 50-60 Hz or 110-120 V~ 50-60 Hz
No Load Speed	3900 min ⁻¹
Linear speed with 16" blade	82.7 m/s (no load), 53.9 m/s (rated)
Blade Diameter	406 mm (16")
Arbor	25.4 mm (1")
Max. Cutting Depth	150 mm (6")
Soft Start & Overload Protection	With
Insulation Class	Class I, (220-240 V models with PRCD / GFCI)
Dimensions (LxWxH)	660 x 259 x 280 mm
Weight	9.6 kg (21.1 lb) 10 kg (22.2 lb) with guide rollers
Characteristics / Certification	

Features

1. LED Indicator Indicates load conditions (electronic & thermal protection).
2. Integrated water feed system with fine adjustable flow and quick release coupling.
3. Tool-free detachable guide rollers for perpendicular cuts and reduced operator fatigue.
4. Tool-free detachable splash guard.
5. Tool-free blade guard angle adjustment. Handles designed for optimal control.
6. Vacuum port for dust or slurry collection with cap.
7. Quick removable brush for slurry.
8. Externally accessible brushes.
9. Hall Effect Switch is completely waterproof and dustproof.

Standard/ Optional Accessories See p. 23

C406 HIGH FREQUENCY CONCRETE SAW

406 mm (16") concrete saw with 6600 W high frequency permanent magnet synchronous motor for up to 150 mm depth of cut. Flush cut capability.



■ Flush Cutting (Optional)



Flush cutting details see p. 12

High Frequency Power Converter

■ P8K



P8K details see p. 22

Model	C406	
Power Input	3Ø~380-480 V 1Ø~200-240 V	6600 W 3600 W (16 A), 5500 W (32 A)*
No Load Speed**	3900 min ⁻¹	
Linear speed with 16" blade	82.9 m/s	
Blade Diameter	406 mm (16")	
Arbor	25.4 mm (1")	
Max. Cutting Depth	150 mm (6")	
Soft Start & Overload Protection	With	
Cable Length	6 M	
Dimensions (LxWxH)	780 x 260 x 300 mm	
Weight	10.5 kg (23.1 lb)	
Characteristics / Certification		

* Maximum input current with a single phase adaptor cable is 16A. If a 32A 220V breaker is available, a 32A rated cable may be used to directly supply the converter for full power.

** Due to the motor design, the no load and the rated load speeds are roughly the same.

Features

1. LED Indicator Indicates load conditions (electronic & thermal protection).
2. Constant speed is maintained regardless of load.
3. Integrated water feed system with fine adjustable flow and quick release coupling.
4. Tool-free detachable guide rollers for perpendicular cuts and reduced operator fatigue.
5. Tool-free detachable splash guard.
6. Tool-free blade guard angle adjustment.
7. Hall Effect Switch is completely waterproof and dustproof.
8. Handles designed for optimal control.
9. Quick removable brush for slurry.

Standard/ Optional Accessories See p. 23

C18 HIGH FREQUENCY CONCRETE SAW

457 mm (18") wet concrete saw with 6600 W high frequency permanent magnet synchronous motor for up to 175 mm depth of cut. With flush cut capability.



■ Flush Cutting (Optional)



Flush cutting details see p. 12

Model	C18
Power Input	3Ø~380-480 V 6600 W 1Ø~200-240 V 3600 W (16 A), 5500 W (32 A)*
No Load Speed**	2800 min ⁻¹
Linear speed with 18" blade	67.0 m/s
Blade Diameter	457 mm (18")
Arbor	25.4 mm (1")
Max. Cutting Depth	175 mm (6")
Soft Start & Overload Protection	With
Cable Length	6 M
Dimensions (LxWxH)	810 x 260 x 310 mm
Weight	11.6 kg (25.5 lb)
Characteristics / Certification	

* Maximum input current with a single phase adaptor cable is 16A. If a 32A 220V breaker is available, a 32A rated cable may be used to directly supply the converter for full power.

** Due to the motor design, the no load and the rated load speeds are roughly the same.

High Frequency Power Converter

■ P8K



P8K details see p. 22

Features

1. LED Indicator Indicates load conditions (electronic & thermal protection).
2. Constant speed is maintained regardless of load.
3. Integrated water feed system with fine adjustable flow and quick release coupling.
4. Tool-free detachable guide rollers for perpendicular cuts and reduced operator fatigue.
5. Tool-free detachable splash guard.
6. Tool-free blade guard angle adjustment.
7. Hall Effect Switch is completely waterproof and dustproof.
8. Handles designed for optimal control.

Standard/ Optional Accessories See p. 23

▪ **Flush Cutting (Optional on C16, C406, C18)**

To perform flush cutting, one must first mount a Flush Cutting Flange Kit (choose A or B), a suitable flush cutting blade, and install the Flush Cut Cover Set. Each kit comes complete with all necessary fasteners.



C16, C406



C18

Flush Cutting Flange Kits



A. HY Pattern Flush Cutting Kit- 1" arbor 6-bolt (60 mm bolt hole circle)



Flush Cutting Blade

88.9 mm bolt hole circle
(for use with the B. HV Pattern Flush Cutting Kit above)



B. HV Pattern Flush Cutting Kit- 1" arbor Longyear 6-bolt (3-1/2" (88.9 mm) bolt hole circle) & 3-bolt combined



Flush Cut Cover Set

For enhanced safety when flush cutting

▪ **Dry Cutting With Dust Skid (Optional on C14, C16)**

With spring-loaded suspension for ideal dust containment when dry cutting.



(14" for C14)



(16" for C16)



▪ **High Frequency Brushless Motor (On C18, C406)**



P8K Power Converter

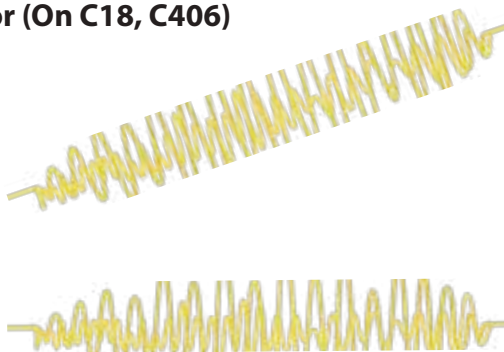

C18



C406

Features



Toggle Latches

Blade Guard with Toggle Latches for quick conversion to Flush cutting



LED Indicator

LED Indicator Indicates load conditions (electronic & thermal protection).



Blade Guard

Tool-free blade guard angle adjustment. Handles designed for optimal control.



Guide Rollers

Tool-free detachable guide rollers for perpendicular cuts and reduced operator fatigue.



Splash Guard

Tool-free detachable splash guard.



Vacuum Port

Vacuum port for dust or slurry collection with cap.

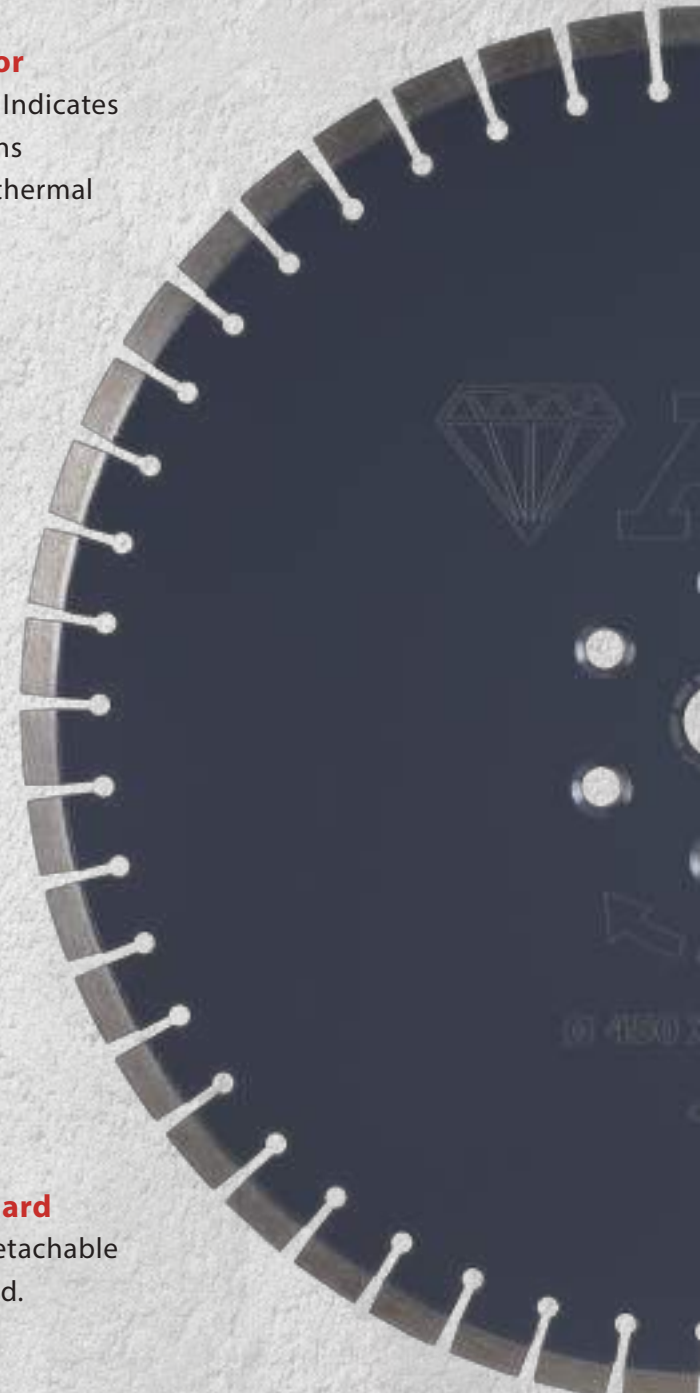

R13 RING SAW

330 mm (13") wet ring saw with 3200 W universal motor for up to 220 mm depth of cut.



Model	R13
Power Input	3200 W (230-240 V), 3000 W (220 V), 2800 W (110-120 V)
Voltage, Frequency	230-240 V~ 50-60 Hz, 220 V~ 50-60 Hz or 110-120 V~ 50-60 Hz
No Load Speed	3900 min ⁻¹
Linear speed	49.2 m/s (no load), 32.0 m/s (rated)
Blade Diameter	330 mm (13")
Max. Cutting Depth	220 mm (8.7")
Soft Start & Overload Protection	With
Insulation Class	Class I, (220-240 V models with PRCD / GFCI)
Dimensions (LxWxH)	730 x 280 x 450 mm
Weight	12.4 kg (27.3 lb)(Not incl. blade)
Characteristics / Certification	

Features

1. Patented One Step Drive Tensioner makes fast and easy blade adjustment and keeps tension equalized.
2. Change saw blade quickly and without disassembly of the cover.
3. High Stability Guide Roller design keeps the blade stable and centralized when beginning the cut.
4. LED Indicator Indicates load conditions (electronic & thermal protection).
5. Flexible upper and bottom splash guards prevent splashing slurry.
6. Hall Effect Switch is completely waterproof and dustproof.
7. Water feed system with fine adjustable flow and quick release coupling.
8. Externally accessible brushes.

Standard/ Optional Accessories See p. 24

R16 HIGH FREQUENCY RING SAW

400 mm wet ring saw with 6600 W high frequency permanent magnet synchronous motor for up to 300 mm depth of cut.



High Frequency Power Converter



P8K details see p. 22

Features

1. Patented One Step Drive Tensioner makes fast and easy blade adjustment and keeps tension equalized.
2. Change saw blade quickly and without disassembly of the cover.
3. High Stability Guide Roller design keeps the blade stable and centralized when beginning the cut.
4. LED Indicator Indicates load conditions (electronic & thermal protection).
5. Flexible upper and bottom splash guards prevent splashing slurry.
6. Hall Effect Switch is completely waterproof and dustproof.
7. Water feed system with fine adjustable flow and quick release coupling.

Model	R16	
Power Input	3Ø~380-480 V	6600 W
	1Ø~200-240 V	3600 W (16 A), 5500 W (32 A)*
No Load Speed**	2500 min ⁻¹	
Linear speed	53 m/s	
Blade Diameter	400 mm (15-3/4")	
Max. Cutting Depth	300 mm (11-13/16")	
Soft Start & Overload Protection	With	
Cable Length	6 M	
Dimensions (LxWxH)	830 x 240 x 460 mm	
Weight	13 kg (28.6 lb)	
Characteristics / Certification		

* Maximum input current with a single phase adaptor cable is 16A. If a 32A 220V breaker is available, a 32A rated cable may be used to directly supply the converter for full power.

** Due to the motor design, the no load and the rated load speeds are roughly the same.

Standard/ Optional Accessories See p. 24

Unparalleled Cutting Depth For A Hand-Held Saw

R13 – 220 mm Cut

With a standard wall saw, you'd need a circular blade diameter of at least 540 mm to match the R13's cutting depth.

330 mm Ring Saw

540 mm Wall Saw

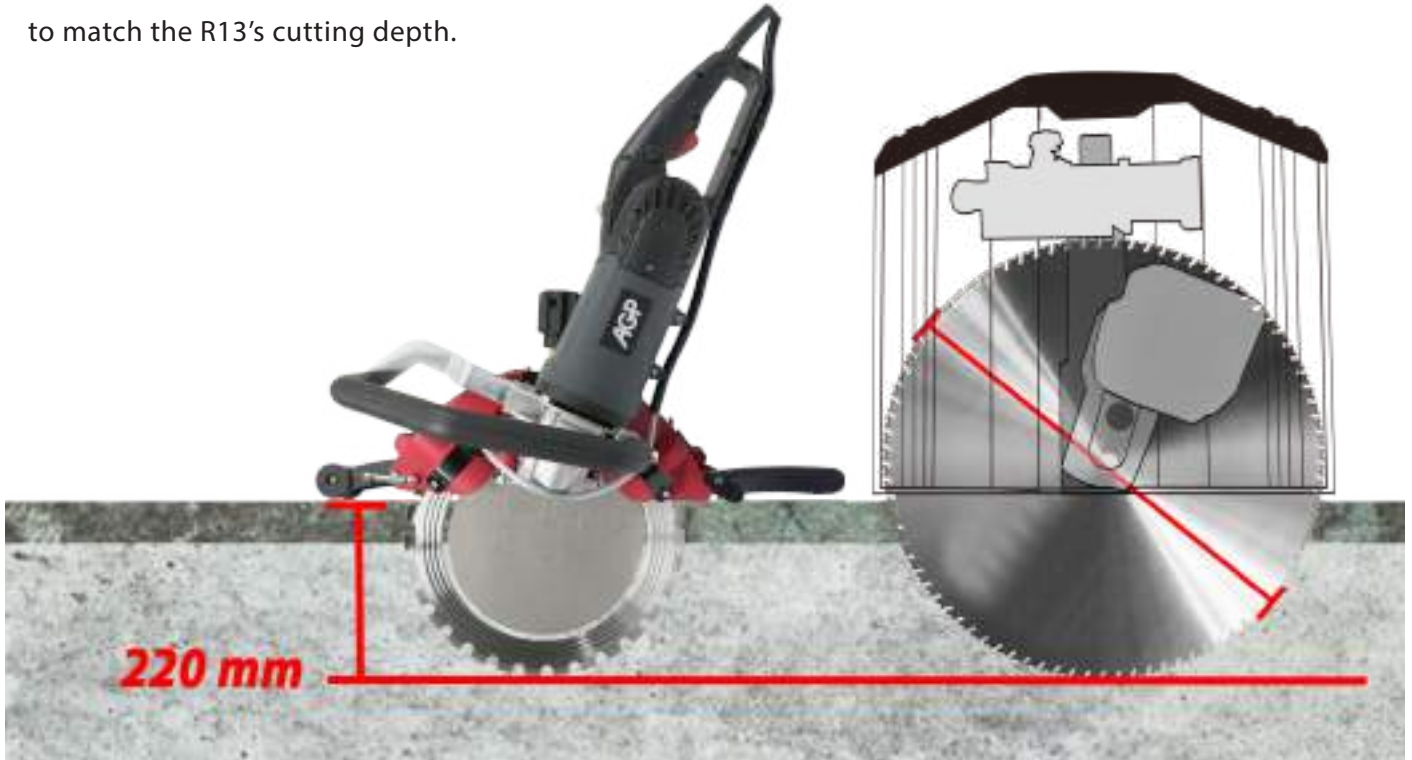

R16 – 300 mm Cut

With a standard wall saw, you'd need a circular blade diameter of at least 700 mm to match the R16's cutting depth.

405 mm Ring Saw

700 mm Wall Saw

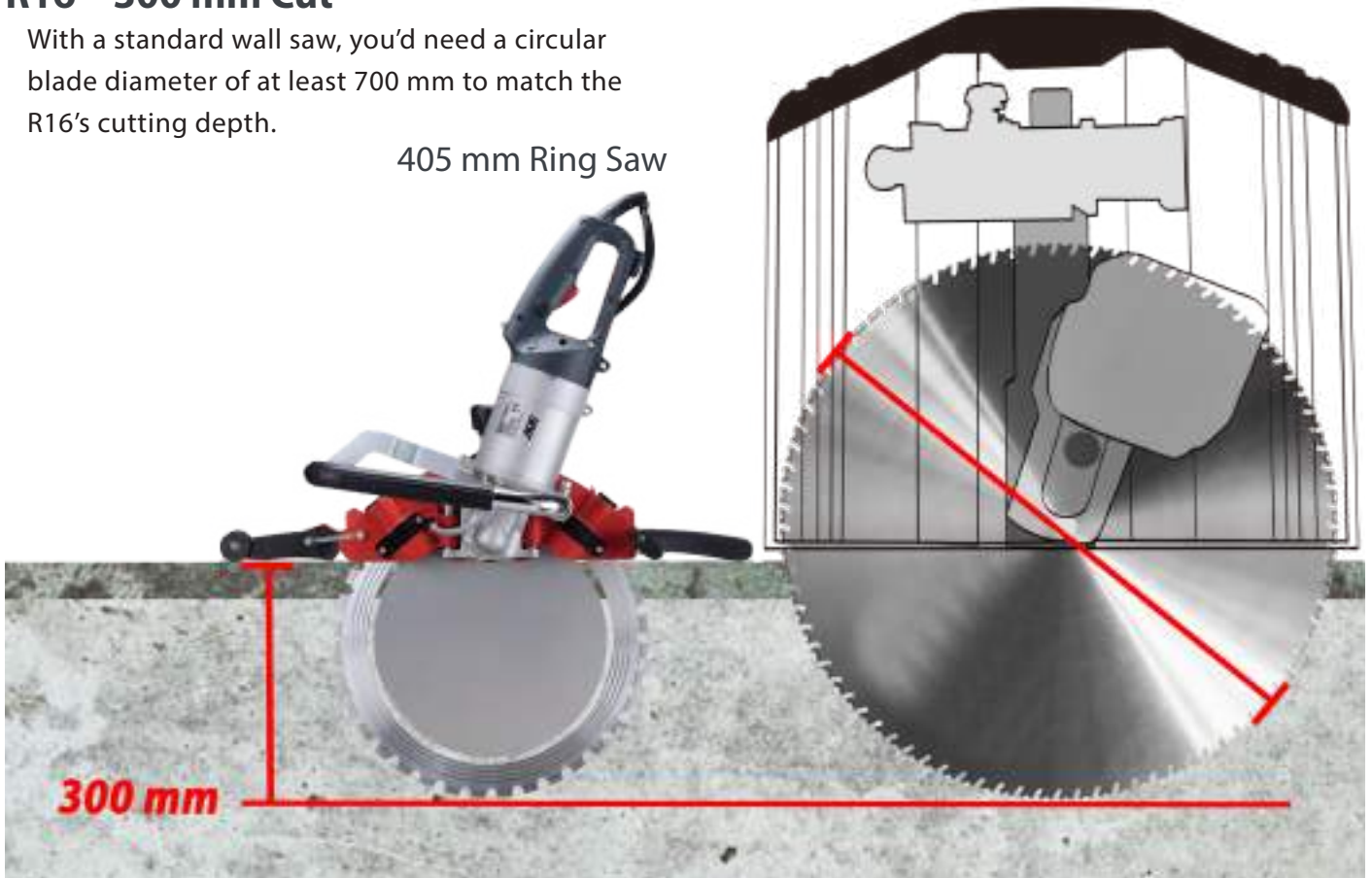

Features



Simple Side-Thrust Tuning

Maximum-stability guide roller design keeps the blade centralized.



One-Step Blade Tensioning System

Patented One- Step Drive Tensioner makes fast and easy blade adjustment and keeps tension equalized.



LED Load Indicator

LED Indicator Indicates load conditions (electronic & thermal protection).



Splash Guards

Flexible upper and bottom splash guards prevent splashing slurry.



Ergonomic Handle Design

Optimum control and minimized fatigue.

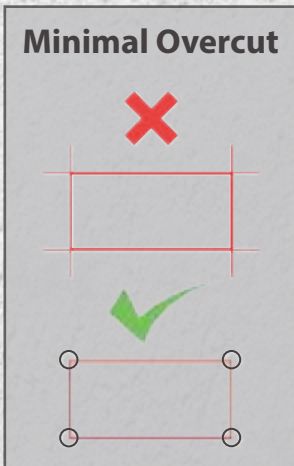

RingSaw
Action Video



Quick & Easy Blade Changing

No need to strip the drive cover to change the blade.

CS11 CONCRETE CHAIN SAW

Concrete chain saw with single phase 3200 W motor and up to 300 mm plunge cutting depth. Excellent for precise corner cut outs with no overcuts.



Model	CS11
Power Input	220 V: 2800 W (certificate), 3200 W (actual) 110 V: 2600 W (certificate), 3000 W (actual)
Voltage, Frequency	220-240 V~ 50-60 Hz or 110-120 V~ 50-60 Hz
No Load Speed	10,000 min ⁻¹
Linear speed	20.7 m/s (no load), 13.4 m/s (rated)
Guide Bar Nominal Length	330 mm (13")
Diamond Chain	25 link
Max. Cutting Depth	300 mm (11.8")
Soft Start & Overload Protection	With
Insulation Class	Class I, (220-240 V models with PRCD / GFCI)
Dimensions (LxWxH)	630 mm (930 mm with guide bar) x 215 mm x 280 mm
Weight	8.0 kg (17.6 lb), 8.94 kg (19.7 lb) with guide bar & chain
Characteristics / Certification	

Features

1. LED Indicator Indicates load conditions (electronic & thermal protection).
2. Bumper Spike for increased leverage.
3. Flexible Splash Flap helps contain slurry.
4. Dual plane horizontal and vertical spirit levels for precise alignment.
5. Wide base for setting tool down and adjusting.
6. Hall Effect Switch is completely waterproof and dustproof.

Standard/ Optional Accessories See p. 24

CS18 HIGH FREQUENCY BRUSHLESS CHAIN SAW

Concrete chainsaw with 6600 W high frequency permanent magnet synchronous motor. Excellent for deep plunge cuts and precise corner cut outs with no overcuts.



High Frequency Power Converter



■ P8K

P8K details see p. 22



7

Features

1. Constant speed is maintained regardless of load.
2. LED Indicator Indicates load conditions (electronic & thermal protection).
3. Bumper Spike for increased leverage.
4. Flexible Splash Flap helps contain slurry.
5. Dual plane horizontal and vertical spirit levels for precise alignment.
6. Wide base for setting tool down and adjusting.
7. Design allows cutting close to the wall.
8. Tool-free bar clamp lever for faster chain tension adjustment.
9. Special motor coupling cable.
10. Hall Effect Switch is completely waterproof and dustproof.

Standard/ Optional Accessories See p. 24

Model	CS18	
Power Input	3Ø~380-480 V	6600 W
	1Ø~200-240 V	3600 W (16 A), 5500 W (32 A)*
No Load Speed**	8500 min ⁻¹	
Linear speed	22.33 m/s (3/8") - 25.7 m/s (0.444")	
Pitch	3/8" or 0.444"	
Guide Bar Nominal Length	12" , 14" , 16" or 19"	
Max. Cutting Depth	470 mm (w / 19" Bar)	
Soft Start & Overload Protection	With	
Dimensions (LxWxH)	635 x 250 x 316 mm	
Weight	8.9 kg (19.5 lb)	
Characteristics / Certification		

* Maximum input current with a single phase adaptor cable is 16A. If a 32A 220V breaker is available, a 32A rated cable may be used to directly supply the converter for full power.

** Due to the motor design, the no load and the rated load speeds are roughly the same.

Features

6600 W Permanent Magnet Synchronous Motor: A Revolution In Brushless Motors

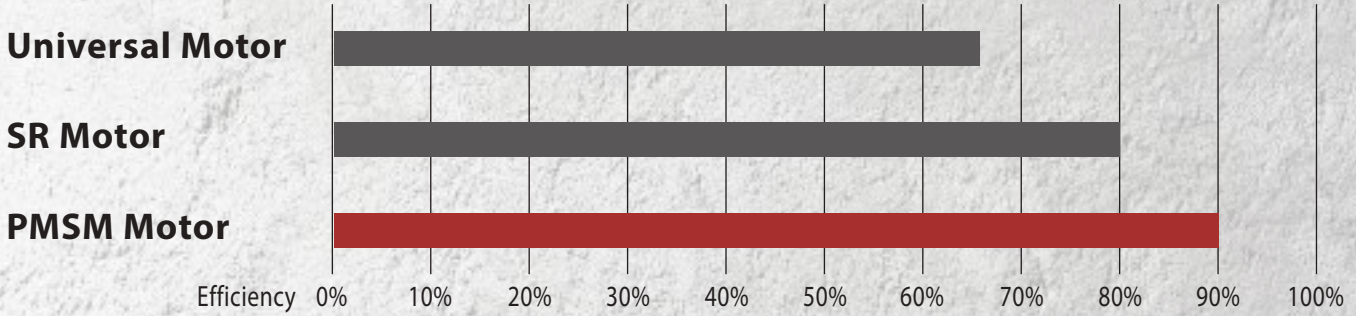

Higher Reliability

No carbon brush changes and longer life time.

Higher Productivity

More efficient PMSM motor for faster results and less wasted energy.

More Power

Higher raw power output for challenging cuts

Slurry Resistant

Uniquely designed to prevent ingress of water, dust, and slurry.

Faster Chain Adjustment

The tool-free bar clamp lever allows chain adjustments with no need for additional tools.

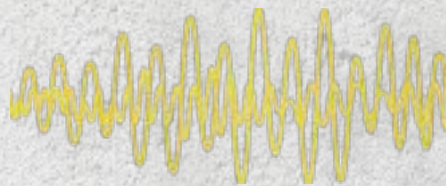

Bumper Spike
Bumper Spike for increased leverage



LED Indicator
LED Indicator
Indicates load conditions



Spirit Levels
Dual plane horizontal and vertical spirit levels for precise alignment



Splash Flap
Flexible Splash Flap
helps contain slurry



Flush Cutting
Special design allows
very close to flush cutting



Bar Clamp Lever
Tool-free bar clamp lever
for faster chain tension
adjustment

P8K POWER CONVERTER

Water cooled 8000 W power converter with special circuitry which allows it to accept **3 phase 380 V and single phase 230 V** supply at the maximum possible power level.

1. Built-in PRCD has full electronic protection for over and under voltage, thermal and current overload supplies high frequency current to the tool.
2. LCD Information Display shows voltage, elapsed hours, error codes, etc. 3 phase power supply cable.
3. Adaptor for single phase supply included. (maximum 16 A)



Model	P8K
Power Input (maximum)	3Ø~380-480 V : 16A 8000 W 1Ø~200-240 V : 32A 7000 W
Min. Water Flow (25°C)	3.5 L/min (1 gpm)
Max. Water Pressure	7 bar (100 psi)
Dimensions (LxWxH)	460 x 220 x 260 mm
Weight	7.1 kg (15.6 lb)



Application: C406, C18, R16, CS18

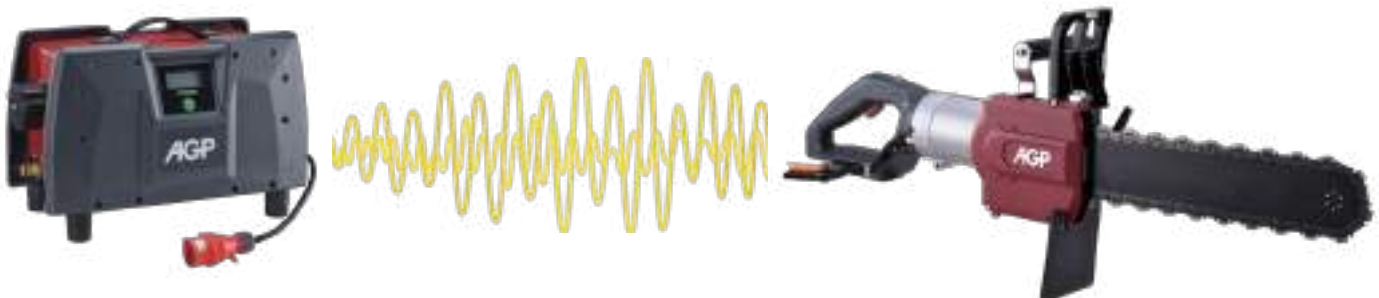

Sawing Accessories

C14 Concrete Saw

Standard Accessories	
M17 Combination Wrench	
Guide Roller Set	
Splash Guard Unit	
Blade Guard Brush	
PRCD / GFCI Interruptor	
Optional Accessories	Part Number
355 mm (14") Diamond Blade	305-00036-000-062
a Dust Skid 14"	0299-0212-0004-002



a Dust Skid (C14)



b Dust Skid (C16, C406)

C16 Concrete Saw

Standard Accessories	
M17 Combination Wrench	
M3 L-hex wrench	
PRCD / GFCI Interruptor (220V models only)	
Optional Accessories	Part Number
b Dust Skid 16"	0299-0212-0004-007
C1 Flush Cutting Flange Kit (60 mm)	0299-0213-0000-001
C2 Flush Cutting Flange Kit (88.9 mm)	0299-0213-0000-002
d 406 mm (16") Flush Cutting Blade (88.9 mm)	305-00036-000-067
e Flush Cut Cover Set	0299-0284-00000-001



C1 Flush Cutting Flange Kit (60 mm)



C2 Flush Cutting Flange Kit (88.9 mm)

C406 High Frequency Concrete Saw

Standard Accessories	
Hex Key (M3)	
Wrench (M17)	
c Flush Cutting Flange Kit (choose 60 mm or 88.9 mm)	
e Flush Cut Cover Set	
Plastic Carry Case	
Optional Accessories	Part Number
d 406 mm (16") Flush Cutting Blade (88.9 mm)	305-00036-000-067

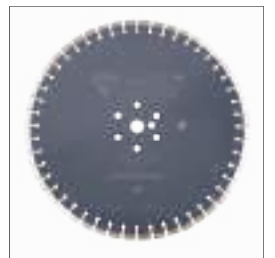

d Flush Cutting Blade

C18 High Frequency Concrete Saw

Standard Accessories	
c Flush Cutting Flange Kits (60 mm or 88.9 mm)	
Flush Cutting Rim Brush	
Plastic Carry Case	
Optional Accessories	Part Number
d 457 mm (18") Flush Cutting Blade (88.9 mm)	305-00036-000-077



e Flush Cut Cover Set

Sawing Accessories

R13 Ring Saw

Standard Accessories	Part Number
T-Wrench	
Face Spanner	
Plastic Carry Case	
f 330 mm Ring Saw Blade	305-00036-000-072
PRCD / GFCI Interruptor (220V models only)	



f Ring Saw Blade

R16 High Frequency Ring Saw

Standard Accessories	Part Number
T-Wrench	
Plastic Carry Case	
Face Spanner	
f 400 mm Ring Saw Blade	305-00036-000-071



g Guide Bar

CS11 Concrete Chain Saw

Standard Accessories
T-Wrench
PRCD / GFCI Interruptor (220 V models only)
Optional Accessories
g Guide Bar (13")
h Diamond Chain (general purpose) (25 link)
i Sprocket 3/8"
Carry Bag

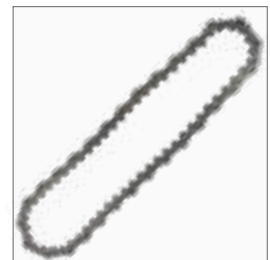

h Diamond Chain

CS18 High Frequency Concrete Chain Saw

Standard Accessories
Snap Ring Pliers
T-Wrench
Hex Key (M4)
Optional Accessories
g Guide Bar (12, 14, 16, or 19")
h Diamond Chain (general purpose)
i Sprocket 3/8" or 0.444"



i Sprocket

SCS7 STONE CUTTING CIRCULAR SAW

A 180 mm wet stone saw with 55 mm depth of cut and 1800 W motor. Use the optional guide rail for precise control.



Features

1. Depth Scale for control of cut.
2. Parallel Guide for straight cuts.
3. Sighting Notch for accurate cutting.
4. Optional Guide Rail for precise control of the cutting process.

Model	SCS7
Power Input	1800 W (220 V), 1680 W (110 V)
Voltage, Frequency	220-240 V~ 50-60 Hz or 110-120 V~ 50-60 Hz
No Load Speed	5800 min ⁻¹
Arbor	22.23 mm (7/8")
Max. Blade Diameter	180 mm
Max. Cutting Depth	55 mm
Overload Protection	With
Soft Start	With
Insulation Class	Class I with PRCD / GFCI
Dimensions (LxWxH)	350 x 270 x 265 mm
Weight	6.7 kg (14.7 lb)
Characteristics / Certification	



Standard Accessories

- Parallel Guide
- Quick-release Water Hose Coupling
- M6 L-Hex Wrench
- PRCD / GFCI Interruptor
- Plastic Carry Case

Optional Accessories

- 7" Diamond Blade
- 4a Aluminum Guide Rails (1400 mm & 800 mm available)
- 4b Guide Rail Connector
- 4c Lever Clamp

SCS8 STONE CUTTING CIRCULAR SAW

A 200 mm stone saw with 70 mm depth of cut and 2200 W constant speed motor. Use the optional guide rail for precise control.



Model	SCS8
Power Input	2200 W (220 V), 1680 W (110 V)
Voltage, Frequency	220-240 V~ 50-60 Hz or 110-120 V~ 50-60 Hz
No Load Speed	6000 min ⁻¹
Arbor	22.23 mm (7/8")
Blade Diameter	200 mm (8") or 180 mm (7")
Cutting Depth (0°)	70 mm (65 mm on rail) 200 mm blade 60 mm (55 mm on rail) 180 mm blade
Cutting Depth (45°)	52 mm (47 mm on rail) 200 mm blade 45 mm (40 mm on rail) 180 mm blade
Cutting Width Range (w/ parallel guide)	10 - 130 mm
Overload Protection	With
Insulation Class	Class I with PRCD / GFCI
Dimensions (LxWxH)	484 x 313 x 198 mm
Weight	5.7 kg (12.5 lb)
Characteristics / Certification	

Features

1. LED Load Indicator & Constant Speed Motor for maximum work efficiency.
2. Suitable for both wet and dry cutting.
3. On-board wrench storage.
4. Bevel Cutting Capability.
5. Hall-Effect Switch is impervious to dust and slurry.
6. Depth Scale for control of cut.
7. Sighting Notches (0°, 30° & 45°) for accurate cutting.
8. Parallel Guide for straight cuts.
9. Optional Guide Rail for precise control of the cutting process.

Optional Accessories

Standard Accessories	
Parallel Guide	
Quick-release Water Hose Coupling	
M6 L-Hex Wrench	
PRCD / GFCI Interruptor	
Plastic Carry Case	
Optional Accessories	
180 mm (7") or 200 mm (8") Diamond Blade	
9a Aluminum Guide Rails (1400 mm & 800 mm available)	
9b Guide Rail Connector	
9c Lever Clamp	

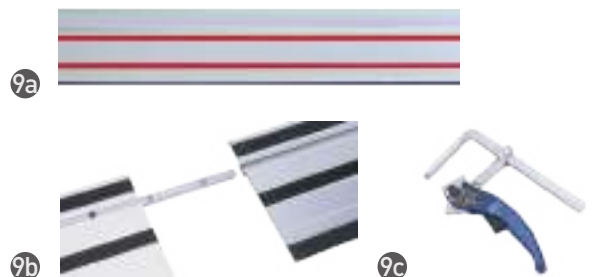

TS9 WET TILE SAW

A 230 mm professional grade, high precision wet tile saw with unique water recirculation design. 48 mm depth of cut. 45° bevel cut capability.



Quick-release table mountings.



Easy mounting 1.5 L water tray

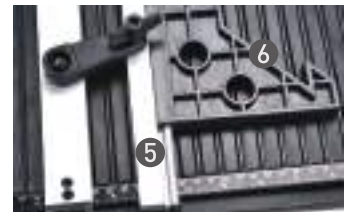

Angle Guide Plate & Micro-adjustable cutting guide

Model	TS9
Motor Type	Single Phase AC Induction
Power Output	0.8 kW (1.1 HP)
Voltage, Frequency	220-240 V~ 50-60 Hz or 110-120 V~ 50-60 Hz
No Load Speed	3000 min ⁻¹ (50 Hz), 3600 min ⁻¹ (60 Hz)
Max. Blade Diameter	230 mm (9")
Blade Bore	25.4 mm (1")
Bevel Capability	0-45°
Max. Cutting Depth-straight	48 mm (1-7/8")
Max. Cutting Depth- at 45°	37 mm (1-7/16")
Rip Cut - Left	305 mm (12")
Rip Cut - Left at 45° Bevel	295 mm (11-39/64")
Rip Cut - Right	147 mm (5-25/32")
Diagonal (Miter) Cut - Left	285 mm (11-7/32")
Diagonal Cut - Left at 45° Bevel	275 mm (10-13/16")
Front of Blade to Table Edge	200 mm (7-7/8")
Ingress Protection	IP44
Dimensions (LxWxH)	660 x 595 x 320 mm
Weight	14.7 kg (32.4 lb)
Characteristics / Certification	CE CB

Features

1. Easy Miter adjustment miters up to 45 degrees.
2. Easy mounting 1.5 L water tray.
3. Quick-release table mountings. Quick tool-free removal of the table for easy cleaning and blade replacement.
4. Rugged, stable, and easy-to-clean table with cutting scale.
5. Micro-adjustable cutting guide always remains parallel.
6. Angle Guide Plate holds work pieces at various angles.

Standard Accessories

- Diamond Blade
- Parallel Cutting Guide
- Angle Guide Plate
- M8 Combination Wrench
- M19 Combination Wrench