

# DIAMOND CORE DRILLING MOTORS

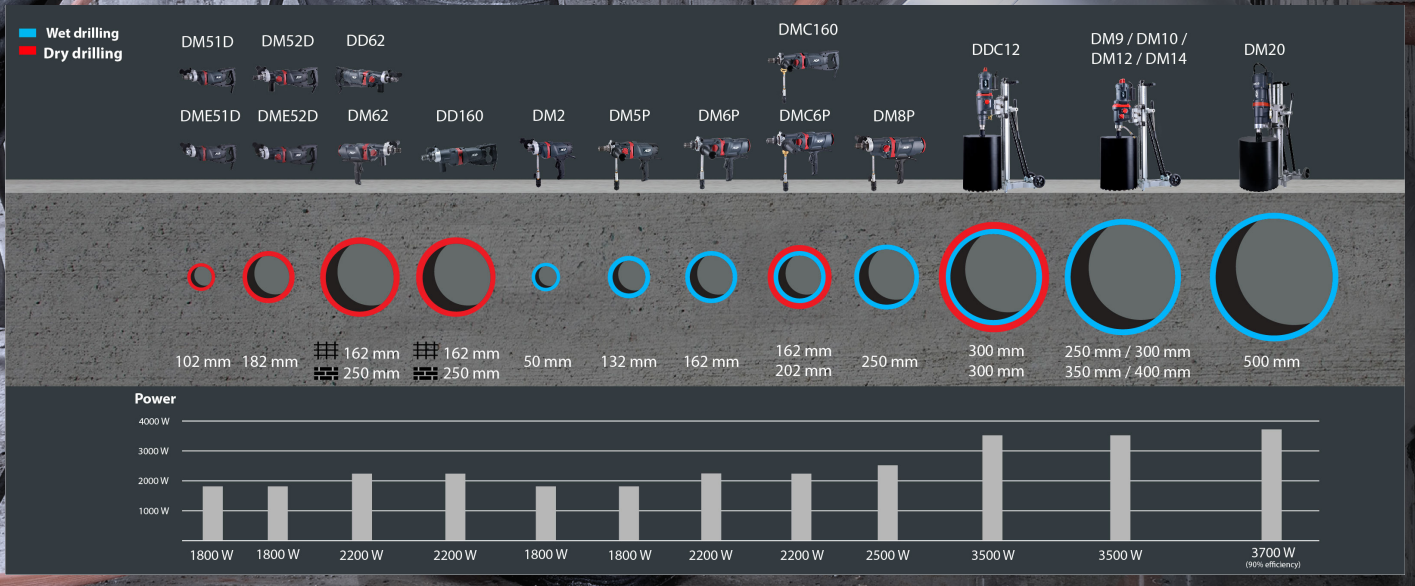

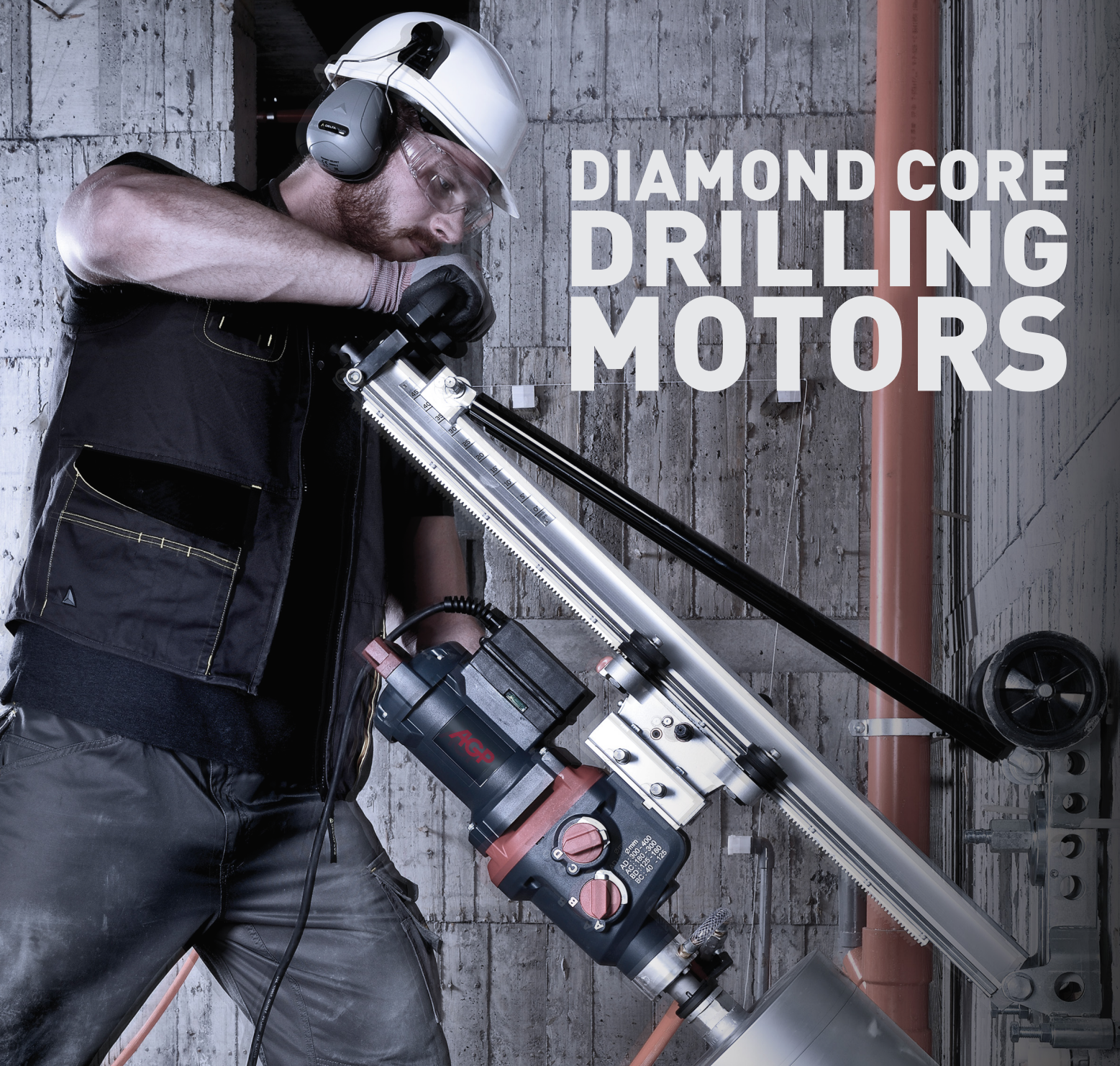

# TC20, TC40, TC402 TILE CORE DRILLS

Wet or dry tile core drills specially designed for core drilling small holes in tiles, ceramics, porcelain, stone, concrete, masonry, glass, and similar materials. Quick-release spindle for easy clearing of cores.



TC20, TC40

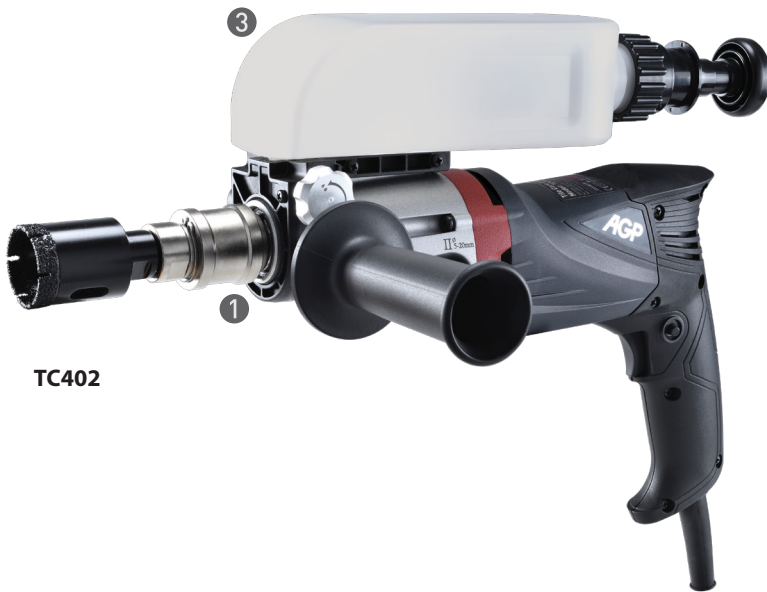

TC402



4 2-speed gear change lever

## Features

1. Quick-release collar for easy clearing of cores.
2. Suction Centering Guide for precise hole positioning and control of slurry and/or dust.
3. Pressurized Water Tank with Flow Regulator (optional).
4. 2-speed motor for a wide range of diameters. (TC402 only).

Model		TC20	TC40	TC402
Power Input		650 W		
Voltage, Frequency		220-240 V~ 50-60 Hz or 110-120 V~ 50-60 Hz		
No Load (Rated Load) Speeds	Gear 1	7500 / (4500) min <sup>-1</sup>	4500 / (2700) min <sup>-1</sup>	4500 / (2700) min <sup>-1</sup>
	Gear 2	N/A	N/A	7500 / (4500) min <sup>-1</sup>
Capacity		20 mm (13/16")	40 mm (1-9/16")	40 mm (1-9/16")
Adapter Thread		G 1/2" (BSP), M14-2.0		
Insulation Class		Class II with PRCD / GFCI		
Neck Diameter		43 mm		
Dimensions (LxWxH)		317 x 100 x 300 mm		348 x 100 x 300 mm
Weight		2.3 kg (5.1 lb)		2.5 kg (5.5 lb)
Characteristics / Certification				

■ **Suction Centering Guide 2**  
(Standard)

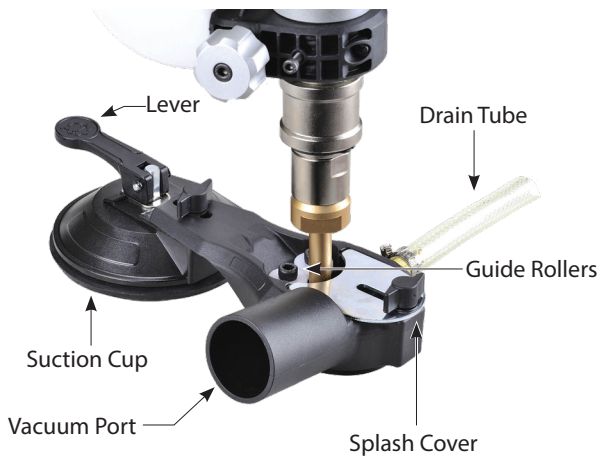

Standard Accessories	
PRCD / GFCI Interrupter	
Suction Centering Guide	
Quick-Release Bit Adapter (1/2" BSP)	
Quick-Release Bit Adapter (M14)	
M22 Wrench	
M27 Wrench	
Side handle	
Collar	
Optional Accessories	
Pressurized Water Tank Kit (0.85 Liter)	
Water Supply Kit	

Tile Diamond Core Bits (For models TC20, TC40, TC402)		
Diameter (mm)	Part Number M14-2.0 Thread	Part Number G 1/2" BSP Thread
6	305-03356-004-084	305-03356-004-096
8	305-03356-004-085	305-03356-004-097
10	305-03356-004-086	305-03356-004-098
12	305-03356-004-087	305-03356-004-099
14	305-03356-004-088	305-03356-004-100
16	305-03356-004-089	305-03356-004-101
18	305-03356-004-090	305-03356-004-102
20	305-03356-004-091	305-03356-004-103
25	305-03356-004-092	305-03356-004-104
30	305-03356-004-093	305-03356-004-105
35	305-03356-004-094	305-03356-004-106
40	305-03356-004-095	305-03356-004-107

■ **Water Supply Kit (Optional)**

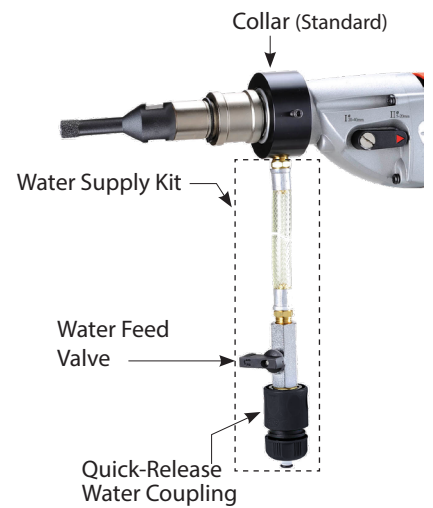

**Tile Diamond Core Bits**

# DM51D, DM51P DRY DIAMOND CORE DRILL MOTORS

Light, compact, high efficiency 1800 W coring motors for dry drilling up to 102 mm.



**DM51D**



**DM51P**



Model	DM51D	DM51P
Power Input	1800 W	
Voltage, Frequency	220-240 V~ 50-60 Hz or 110-120 V~ 50-60 Hz	
No Load (Rated Load) Speeds	3600 (2160) min <sup>-1</sup>	
Percussion Frequency, No Load (Rated Load)	56,000 (36,400) b/min	
Spindle Thread	1/2" BSP female (also available M18-2.5 male) (Specify when ordering)	
Capacity-Dry	102 mm (4")	
Soft Start & Overload Protection	With	
Mechanical Safety Clutch	With	
Insulation Class	Class II	
Neck Diameter	60 mm	60 mm
Dimensions (LxWxH)	450 x 90 x 210 mm	390 x 90 x 280 mm
Weight	4.6 kg	4.6 kg
Characteristics / Certification		

## Features

1. Single-speed gearbox with clutch.
2. Electronic motor management with soft start, overload and thermal protection.
3. Horizontal spirit level for precise alignment.
4. Hall Effect Switch is completely waterproof and dustproof.
5. Switchable soft percussion for optimized dry drilling.
6. Side handle in-line with spindle centerline for best control.

**Standard/ Optional Accessories**  
See p. 52

# DM52D, DM52P DRY/WET DIAMOND CORE DRILL MOTORS

Light, high efficiency 1800 W, 2-speed coring motors for dry drilling up to 182 mm and occasional wet drilling up to 82 mm.



DM52D



DM52P

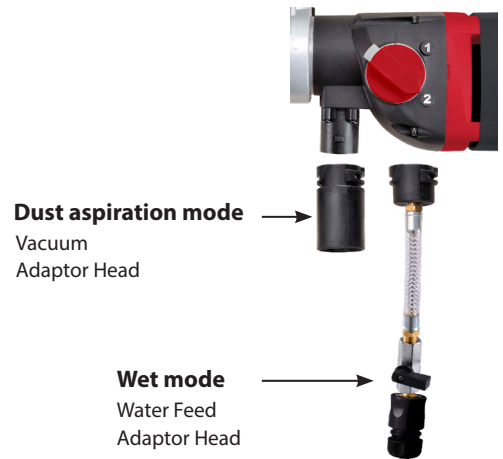

Model	DM52D	DM52P
Power Input	1800 W	
Voltage, Frequency	220-240 V~ 50-60 Hz or 110-120 V~ 50-60 Hz	
No Load (Rated Load) Speeds	Gear 1 1800 (1080) min <sup>-1</sup> Gear 2 3600 (2160) min <sup>-1</sup>	
Percussion Frequency, No Load (Rated Load)	Gear 1 29,000 (18,850) b/min Gear 2 56,000 (36,400) b/min	
Spindle Thread	1-1/4" UNC male & 1/2" BSP female (also available: 1/2" BSP female or M18-2.5 male) (Specify when ordering)	
Capacity-Dry	182 mm (7")	
Capacity-Wet	82 mm (3-1/4")	
Soft Start & Overload Protection	With	
Mechanical Safety Clutch	With	
Insulation Class	Class II with PRCD / GFCI	
Neck Diameter	60 mm	60 mm
Dimensions (LxWxH)	505 x 105 x 210 mm	450 x 105 x 280 mm
Weight	5 kg (11.0 lb)	4.9 kg (10.8 lb)
Characteristics / Certification		

## Features

- 2-speed gearbox with clutch for a wide range of sizes.
- Electronic motor management with soft start, overload and thermal protection.
- Horizontal spirit level for precise alignment.
- Hall Effect Switch is completely waterproof and dustproof.
- Switchable soft percussion for optimized dry drilling.
- Side handle in-line with spindle centerline for best control.

**Standard/ Optional Accessories**  
See p. 52

## DME51D DRY DIAMOND CORE DRILL MOTOR

A compact, high efficiency 1-speed 1800 W dry drilling motor for drilling up to 102 mm. Suitable for drilling of highly abrasive materials. Switchable soft percussion allows optimal dry drilling performance.



## DME52D DRY DIAMOND CORE DRILL MOTOR

A compact, high efficiency 2-speed 1800 W drilling motor for dry drilling up to 182 mm. Suitable for drilling of highly abrasive materials. Switchable soft percussion allows optimal dry drilling performance.



Model	DME51D	DME52D	
Power Input	1800 W		
Voltage, Frequency	220-240 V~ 50-60 Hz or 110-120 V~ 50-60 Hz		
No Load (Rated Load) Speeds	3600 (2160) min <sup>-1</sup>	Gear 1	1800 (1080) min <sup>-1</sup>
		Gear 2	3600 (2160) min <sup>-1</sup>
Percussion Frequency, No Load (Rated Load)	56,000 (36,400) b/min	Gear 1	29,000 (18,850) b/min
		Gear 2	56,000 (36,400) b/min
Capacity-Dry	102 mm (4")	182 mm (7")	
Soft Start & Overload Protection	With		
Spindle Thread	M16-2.0 male or M18-2.5 male (Specify when ordering)		
Insulation Class	Class II		
Dimensions (LxWxH)	450 x 90 x 210 mm	505 x 105 x 210 mm	
Weight	4.7 kg (10.4 lb)	4.9 kg (10.8 lb)	
Characteristics / Certification			

■ **External Dust Extractor Head For Banana Slot Type Bits (Optional)**



Three thread types available:  
 M16 female to M16 male  
 M18 female to M16 male  
 M18 female to M18 male  
 See p. 50

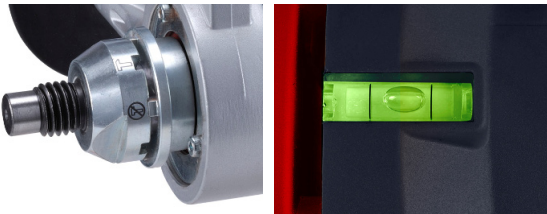

■ **Vacuum Collector Pad (Optional)**

This device adheres to the wall by vacuum cleaner suction and very effectively collects the dust right at the source. Various rings are available for different core sizes. (Details see p. 54)

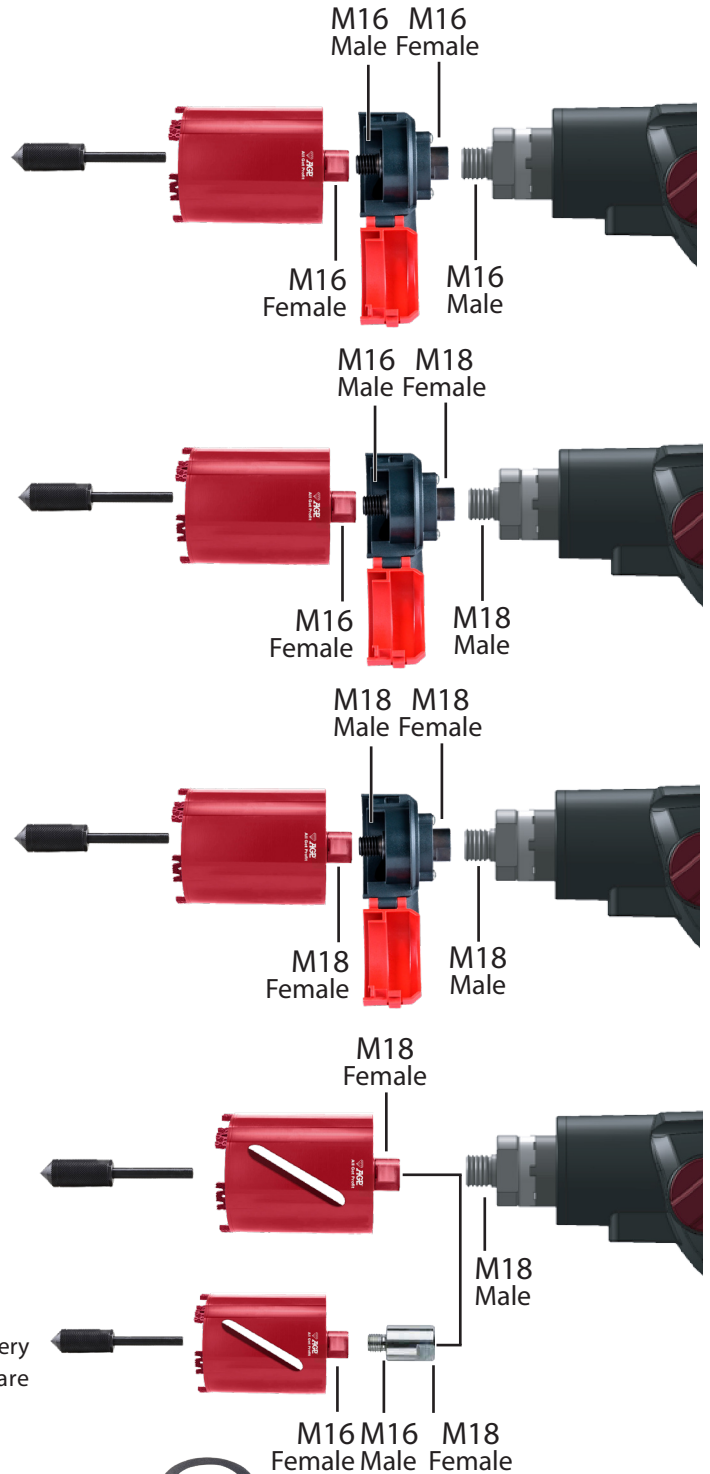

**Features**

1. Gear box with mechanical clutch.
2. Smart Electronic Control with soft-start, thermal protection, and overload protection.
3. Switchable soft percussion for optimized dry drilling.
4. Side Handle in-line with spindle centerline for best control.
5. Hall Effect Switch is completely waterproof and dustproof.
6. Built in horizontal levels for precision.
7. External Dust Extractor Head for use with 50 to 82 mm banana slot type bits (Optional).
8. Spring-loaded Centering Pilot for L 85mm bits or for L 65mm bits. (Optional).

**Standard/ Optional Accessories See p. 52**



# DD160 DRY DIAMONDCORE DRILL MOTOR FOR REINFORCED CONCRETE

A 2-speed 2200 W dry drilling motor for drilling up to 162 mm in reinforced concrete and 250 mm in brick. Excellent for overhead drilling, operation in sub-zero temperatures and any situation where water cannot be used. Perfect for hollow-core slabs. Through-the-spindle dust extraction and switchable soft percussion allow optimal dry drilling performance.



## Features

1. 2-Speed Gear Box with clutch.
2. Smart Electronic Control with soft-start, thermal protection, and overload protection.
3. Highly visible LED indicator for optimizing drilling efficiency with overload and overheat warning.
4. Switchable soft percussion for optimized dry drilling.
5. Hall Effect Switch is completely waterproof and dustproof.
6. Anti-seize ring to keep core bits from getting stuck on the spindle.
7. Soft-Grip Side Handle in-line with spindle centerline for best control.
8. Built in horizontal level for precision.

**Standard/ Optional Accessories See p. 52**

Model	DD160	
Power Input	2200 W (230-240 V), 2000 W (220 V), 1700 W (110-120 V)	
Voltage, Frequency	230-240 V~ 50-60 Hz, 220 V~ 50-60 Hz or 110-120 V~ 50-60 Hz	
No Load (Rated Load) Speeds	Gear 1	1250 / (750) min <sup>-1</sup>
	Gear 2	2600 / (1500) min <sup>-1</sup>
Percussion Frequency, No Load (Rated Load)	Gear 1	25,000 (15,000) b/min
	Gear 2	50,000 (32,500) b/min
Capacity-Dry (Reinforced Concrete)	162 mm (6-1/2")	
Capacity-Dry (Brick)	250 mm (10")	
Soft Start & Overload Protection	With	
Gear Oil Type	80W-90	
Gear Oil Capacity	200 ml	
Spindle Thread	1-1/4" UNC male & 1/2" BSP female	
Insulation Class	Class II	
Dimensions (LxWxH)	550 x 130 x 160 mm	
Weight	6.0 kg (13.2 lb)	
Characteristics / Certification		

# DD62 DRY DIAMOND CORE DRILL MOTOR FOR REINFORCED CONCRETE

A heavy-duty 2-speed 2200 W dry drilling motor for drilling up to 162 mm in reinforced concrete and 250 mm in brick. Excellent for overhead drilling, operation in sub-zero temperatures and any situation where water cannot be used. Perfect for hollow-core slabs. Through-the-spindle dust extraction and switchable soft percussion allow optimal dry drilling performance.



## Features

1. 2-Speed Gear Box with clutch.
2. Smart Electronic Control with soft-start, thermal protection, and overload protection.
3. All metal construction for optimized cooling, durability, and maximum strength.
4. Switchable soft percussion for optimized dry drilling.
5. LED indicator for optimizing drilling efficiency with overload and overheat warning.
6. Hall Effect Switch is completely waterproof and dustproof.
7. Anti-seize ring to keep core bits from getting stuck on the spindle.
8. Side Handle in-line with spindle centerline for best control.
9. Built in vertical and horizontal levels for precision.

**Standard/ Optional Accessories See p. 52**

Model	DD62
Power Input	2200 W (230-240 V), 2000 W (220 V), 1700 W (110-120 V)
Voltage, Frequency	230-240 V~ 50-60 Hz, 220 V~ 50-60 Hz or 110-120 V~ 50-60 Hz
No Load (Rated Load) Speeds	Gear 1 1250 (750) min <sup>-1</sup> Gear 2 1900 (1140) min <sup>-1</sup>
Percussion Frequency, No Load (Rated Load)	Gear 1 25,000 (16,250) b/min Gear 2 38,000 (24,700) b/min
Capacity-Dry (Reinforced Concrete)	162 mm (6-1/2")
Capacity-Dry (Brick)	250 mm (10")
Soft Start & Overload Protection	With
Gear Oil Type	80W-90
Gear Oil Capacity	200 ml
Spindle Thread	1-1/4" UNC male & 1/2" BSP female
Insulation Class	Class II
Dimensions (LxWxH)	530 x 130 x 215 mm
Weight	6.5 kg (14.3 lb)
Characteristics / Certification	

# DM62 DRY DIAMOND CORE DRILL MOTOR FOR REINFORCED CONCRETE

A heavy-duty 2-speed 2200 W dry drilling motor for drilling up to 162 mm in reinforced concrete and 250 mm in brick. Excellent for overhead drilling, operation in sub-zero temperatures and any situation where water cannot be used. Perfect for hollow-core slabs. Through-the-spindle dust extraction and switchable soft percussion allow optimal dry drilling performance.

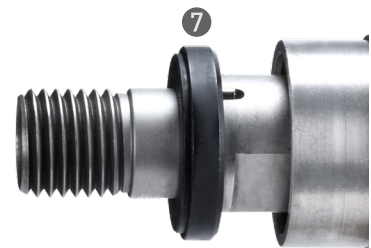
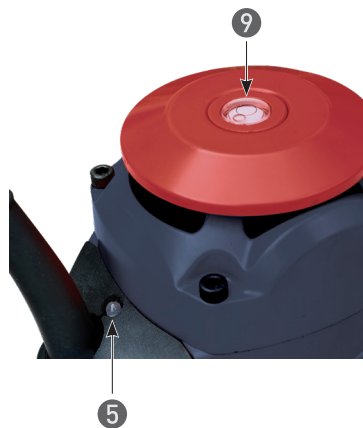



DM62



DM62+AS200

## Features

1. 2-Speed Gear Box with clutch.
2. Smart Electronic Control with soft-start, thermal protection, and overload protection.
3. All metal construction for optimized cooling, durability, and maximum strength.
4. Switchable soft percussion for optimized dry drilling.
5. LED indicator for optimizing drilling efficiency with overload and overheat warning.
6. Hall Effect Switch is completely waterproof and dustproof.
7. Anti-seize ring to keep core bits from getting stuck on the spindle.
8. Side Handle in-line with spindle centerline for best control.
9. Built in vertical and horizontal levels for precision.

**Standard/ Optional Accessories See p. 52**

Model	DM62	
Power Input	2200 W (230-240 V), 2000 W (220 V), 1700 W (110-120 V)	
Voltage, Frequency	230-240 V~ 50-60 Hz, 220 V~ 50-60 Hz or 110-120 V~ 50-60 Hz	
No Load (Rated Load) Speeds	Gear 1	1250 (750) min <sup>-1</sup>
	Gear 2	1900 (1140) min <sup>-1</sup>
Percussion Frequency, No Load (Rated Load)	Gear 1	25,000 (16,250) b/min
	Gear 2	38,000 (24,700) b/min
Capacity-Dry (Reinforced Concrete)	162 mm (6-1/2")	
Capacity-Dry (Brick)	250 mm (10")	
Soft Start & Overload Protection	With	
Gear Oil Type	80W-90	
Gear Oil Capacity	200 ml	
Spindle Thread	1-1/4" UNC male & 1/2" BSP female	
Insulation Class	Class II	
Dimensions (LxWxH)	430 x 122 x 290 mm	
Weight	6.3 kg (13.6 lb)	
Characteristics / Certification		

# DM2 WET DIAMOND CORE DRILL MOTOR

A compact 1-speed 1800 W wet drilling motor designed for fast wet drilling of small diameters from 10 mm up to 50 mm in reinforced concrete. Handles rebar well and is ideal for chemical anchors and similar applications.

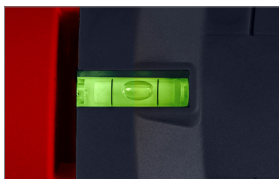

Model	DM2
Power Input	1800 W
Voltage, Frequency	220-240 V~ 50-60 Hz or 110-120 V~ 50-60 Hz
No Load (Rated Load) Speed	6500 (4225) min <sup>-1</sup>
Capacity-Wet	50 mm (2")
Spindle Thread	1/2" BSP Female
Soft Start & Overload Protection	With
Mechanical Safety Clutch	With
Neck Diameter	60 mm
Insulation Class	Class II with PRCD / GFCI
Dimensions (LxWxH)	360 x 90 x 280 mm
Weight	4.5 kg (9.9 lb)
Characteristics / Certification	

## Features

1. 1-speed Gear Box with clutch.
2. Smart Electronic Control with thermal protection and overload protection.
3. Side Handle in-line with spindle centerline for best control.
4. Built in horizontal levels for precision.

**Standard/ Optional Accessories See p. 55**

# DM5P, DM5D WET DIAMOND CORE DRILL MOTORS

A compact, high efficiency 2-speed 1800 W wet drilling motor for drilling up to 132 mm.



DM5P



DM5D

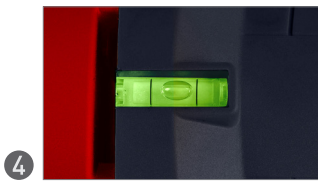

## Features

1. 2-speed Gear Box with clutch.
2. Smart Electronic Control with thermal protection and overload protection.
3. Side Handle in-line with spindle centerline for best control.
4. Built in horizontal levels for precision.
5. Hall Effect Switch is completely waterproof and dustproof.

**Standard/ Optional Accessories See p. 55**

Model	DM5P	DM5D
Power Input	1800 W	
Voltage, Frequency	220-240 V~ 50-60 Hz or 110-120 V~ 50-60 Hz	
No Load (Rated Load)	Gear 1	1500 (780) min <sup>-1</sup>
Speeds	Gear 2	2500 (1400) min <sup>-1</sup>
Capacity-Wet	132 mm (5-1/4")	
Spindle Thread	1-1/4" UNC male & 1/2" BSP female	
Neck Diameter	60 mm	
Insulation Class	Class II with PRCD / GFCI	
Dimensions (LxWxH)	450 x 105 x 280 mm	505 x 105 x 210 mm
Weight	5.35 kg (11.8 lb)	5.46 kg (12.0 lb)
Characteristics / Certification		

# DMC160 WET / DRY DIAMOND CORE DRILL MOTOR

A 3-speed 2200 W wet and dry drilling motor for drilling up to 162 mm in wet, and 202 mm in dry. An excellent choice for an all-around tool for many tasks.



Model	DMC160
Power Input	2200 W (230-240 V), 2000 W (220 V), 1700 W (110-120 V)
Voltage, Frequency	230-240 V~ 50-60 Hz, 220 V~ 50-60 Hz or 110-120 V~ 50-60 Hz
No Load Speeds	1000 / 1600 / 4600 min <sup>-1</sup>
Rated Load Speeds	650 / 1040 / 2890 min <sup>-1</sup>
Capacity-Wet	Hand-Held : 82 mm (3-1/4") Rig-Mounted : 162 mm (6-1/2")
Capacity-Dry	202 mm (8")
Gear Oil Type	80W-90
Gear Oil Capacity	200 ml
Spindle Thread External / Internal	1-1/4" UNC male & 1/2" BSP female
Neck Diameter	60 mm
Soft Start & Overload Protection	With
Mechanical Safety Clutch	With
Insulation Class	Class II with PRCD / GFCI
Dimensions (LxWxH)	528 x 106 x 145 mm
Weight	5.8 kg (12.8 lb)
Characteristics / Certification	

**Brass Claw-Type Couplings**

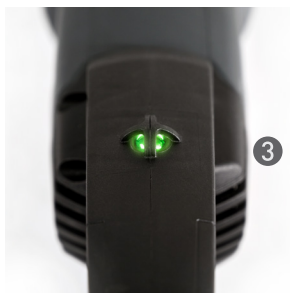
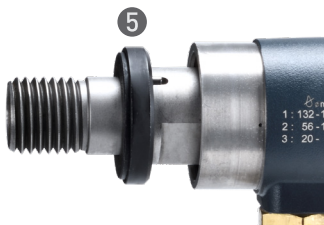
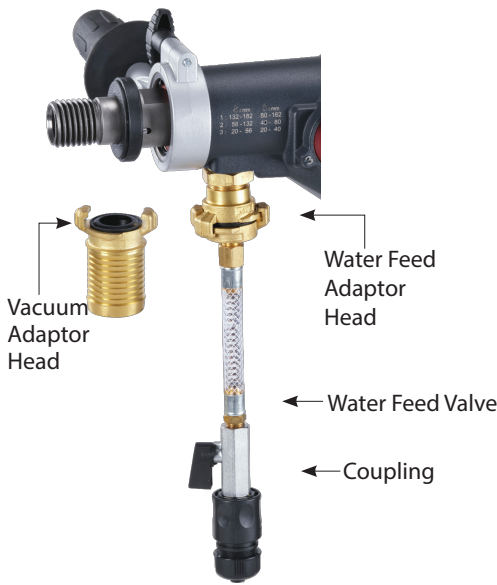

Mounted to AS200 Drill Stand + Water Collector + VB400 Vacuum Plate (See p. 60-61)

**Features**

1. 3-Speed Gear Box with clutch.
2. Smart Electronic Control with soft start, thermal protection, and overload protection.
3. Highly visible LED indicator for optimizing drilling efficiency with overload and overheat warning.
4. Hall Effect Switch is completely waterproof and dustproof.
5. Anti-seize ring to keep core bits from getting stuck on the spindle.
6. Side Handle in-line with spindle centerline for best control.
7. Built in horizontal level for precision.

**Standard/ Optional Accessories See p. 54**



## DM6P, DM6D WET DIAMOND CORE DRILL MOTORS

A heavy duty 3-speed 2200 W wet drilling motor for wet drilling up to 162 mm. Featuring all-metal construction for optimized cooling, durability, and maximum strength.



## DMC6P, DMC6D WET / DRY DIAMOND CORE DRILL MOTORS

A heavy duty 3-speed 2200 W wet and dry drilling motor for drilling up to 162 mm in wet, and 202 mm in dry. Featuring all-metal construction for optimized cooling, durability, and maximum strength.



**Brass Claw-Type Couplings**

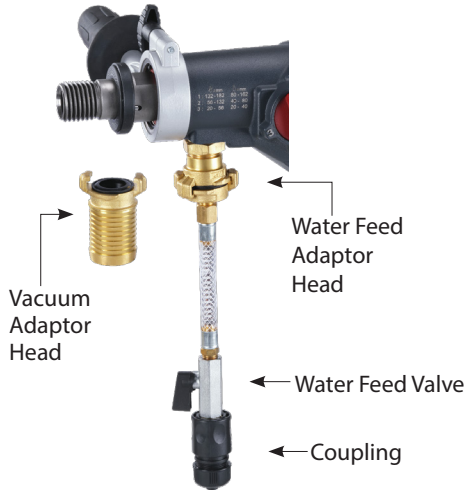

Mounted to AS200 Drill Stand (See p. 58)

**Features**

1. Aluminum alloy construction for optimized cooling, durability, and light weight.
2. Smart electronic motor management with soft start, overload and thermal protection.
3. 3-speed oil bath gearbox with clutch.
4. Side handle in-line with spindle centerline for best control.
5. LED Indicator clearly indicates load conditions.
6. Water supply kit with quick-release water hose adaptor.
7. Anti-seize ring to keep core bits from getting stuck on the spindle.
8. Vertical and horizontal levels for precision.

**Standard/ Optional Accessories See p. 54~55**

Model	DM6P	DM6D	DMC6P	DMC6D
Power Input	2200 W (230-240 V), 2000 W (220 V), 1700 W (110-120 V)			
Voltage, Frequency	230-240 V~ 50-60 Hz, 220 V~ 50-60 Hz or 110-120 V~ 50-60 Hz			
No Load Speeds	930 / 1520 / 4270 min <sup>-1</sup>			
Rated Load Speeds	560 / 910 / 2560 min <sup>-1</sup>			
Capacity-Wet	Hand-Held : 82 mm (3-1/4") Rig-Mounted : 162 mm (6-1/2")			
Capacity-Dry	N/A	N/A	202 mm (8")	202 mm (8")
Gear Oil Type	80W-90			
Gear Oil Capacity	200 ml			
Spindle Thread External / Internal	1-1/4" UNC male & 1/2" BSP female			
Neck Diameter	60 mm			
Soft Start & Overload Protection	With			
Mechanical Safety Clutch	With			
Insulation Class	Class I with PRCD / GFCI			
Dimensions (LxWxH)	437 x 115 x 289 mm	528 x 106 x 145 mm	437 x 115 x 289 mm	528 x 106 x 145 mm
Weight	6.3 kg (13.9 lb)	6.3 kg (13.9 lb)	6.4 kg (14.1 lb)	6.4 kg (14.1 lb)
Characteristics / Certification				

# DM8P WET DIAMOND CORE DRILL MOTOR

A heavy duty 3-speed 2500 W wet drilling motor for drilling up to 250 mm. Featuring constant speed electronics for even drilling speed and longer core bit life.



## Features

1. High output motor with Constant Speed Electronics.
2. Smart Electronic Control with soft-start, thermal protection, and overload protection.
3. 3-speed oil bath gear box with clutch.
4. Highly visible LED load indicator for optimizing drilling efficiency.
5. Anti-seize ring to keep core bits from getting stuck on the spindle.
6. Side handle in-line with spindle centerline for best control.

**Standard/ Optional Accessories See p. 55**

Model	DM8P
Power Input	2500 W (220 V), 2200 W (110 V)
Voltage, Frequency	220-240 V~ 50-60 Hz or 110-120 V~ 50-60 Hz
No Load Speeds	480 / 1050 / 2200 min <sup>-1</sup>
Rated Load Speeds	320 / 700 / 1450 min <sup>-1</sup>
Capacity-Wet	Hand-Held: 82 mm (3-1/4") Rig-Mounted: 250 mm (10 ")
Soft Start & Overload Protection	With
Gear Oil Type	80W-90
Gear Oil Capacity	300 ml
Spindle Thread External / Internal	1-1/4" UNC male & 1/2" BSP female
Neck Diameter	60 mm
Insulation Class	Class I with PRCD / GFCI
Dimensions (LxWxH)	463 x 127 x 310 mm
Weight	7.3 kg (16.0 lb)
Characteristics / Certification	

# DDC12 SOFT PERCUSSION DIAMOND CORE DRILL MOTOR FOR BOTH DRY & WET DRILLING

A heavy-duty 3-speed 3500 W combined dry and wet drilling motor for drilling up to 300 mm dry or wet in reinforced concrete. Its soft percussion function and convertible port allows vacuum connection for dry drilling, and water feed for wet drilling, allowing the motor to keep its wet drilling capabilities, while adding the capability to dry drill reinforced concrete.



## Features

1. Anti-seize ring to keep core bits from getting stuck on the spindle.
2. Switchable Soft Percussion for effective dry drilling.
3. Sturdy 3-speed Gear Box with oil bath lubrication and mechanical clutch.
4. Advanced Electronic Control with soft-start, thermal protection, and overload protection.
5. Surge Function lets the operator easily know that the motor is near overload conditions by pulsing the motor without actually tripping out.
6. Slow-Start function, a unique automatic hole starting function that reduces motor speed for a short time to allow the kerf to be started.
7. Aluminum housing for better cooling and durability.
8. Vertical and horizontal levels for precision.
9. LED Load Indicator for visual monitoring of load conditions.
10. Special Waterproof Switch. The switch's reed-type operative element is completely impervious to water, dust or slurry.
11. Convertible Port for vacuum connection or water supply.
12. Quick-Release Water Feed and Vacuum Adapter Heads.

Model	DDC12
Power Input	3500 W / 16 A (230 V), 2800 W / 25 A (110 V)
Voltage, Frequency	220-240 V~ 50-60 Hz or 110-120 V~ 50-60 Hz
No Load Speeds	450 / 810 / 1300 min <sup>-1</sup>
Rated Load Speeds	270 / 480 / 780 min <sup>-1</sup>
Percussion Frequency, Rated Load	6,480 / 11,520 / 18,720 b/min
Capacity-Dry (RC)	Ø300 mm (12")
Capacity-Wet	Ø300 mm (12")
Gear Oil Type	80W-90
Gear Oil Capacity	625 ml
Spindle Thread	1-1/4" UNC male & 1/2" BSP female
Insulation Class	Class I with PRCD / GFCI (110-120V w/o PRCD / GFCI)
Soft Start & Overload Protection	With
Dimensions (LxWxH)	623 x 149 x 213 mm
Weight	13 kg (28.6 lb)
Characteristics / Certification	

## DM9, DM10, DM12 DIAMOND CORE DRILL MOTORS

High efficiency 3-speed, 3500 W rig-mounted drilling motors with aluminum body. Three models with optimized gearing for different drilling requirements. Choose the version which best suits your drilling needs.



## DM14 RIG-MOUNTED DIAMOND CORE DRILL MOTOR

A high efficiency 4-speed, 3500 W motor with Aluminum body, optimized for a wider range of drill sizes in one tool.





■ **Optional Accessories: 40 mm Spacer Kit**

To provide clearance for the switch box when mounting the motor to some models of other manufacturers' rigs. (The spacer also adds an extra 80 mm to the maximum core bit diameter with a given stand.)

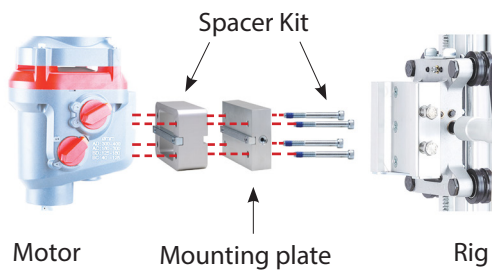

**Standard/ Optional Accessories See p. 55**

1. Sturdy 4-speed Gear Box with oil bath lubrication and mechanical clutch.
2. Advanced Electronic Control with soft-start, thermal protection, and overload protection.
3. Surge Function lets the operator easily know that the motor is near overload conditions by pulsing the motor without actually tripping out.
4. Slow-Start function, a unique automatic hole starting function that reduces motor speed for a short time to allow the kerf to be started.
5. Vertical and horizontal levels for precision.
6. Aluminum housing for better cooling and durability.
7. Anti-seize ring to keep core bits from getting stuck on the spindle.
8. Quick-replaceable water seals.
9. Special Waterproof Switch The switch's reed-type operative element is completely impervious to water, dust or slurry, thus eliminating a common failure point in coring motors. The switch also features anti-restart function.
10. LED Load Indicator for visual monitoring of load conditions.

Model	DM9	DM10	DM12	DM14
Power Input	3500 W / 16 A (220 V), 2800 W / 25 A (110 V)			
Voltage, Frequency	220-240 V~ 50-60 Hz or 110-120 V~ 50-60 Hz			
No Load Speeds	550 / 1000 / 1600 min <sup>-1</sup>	450 / 810 / 1300 min <sup>-1</sup>	350 / 600 / 1000 min <sup>-1</sup>	385 / 530 / 975 / 1340 min <sup>-1</sup>
Rated Load Speeds	345 / 630 / 1000 min <sup>-1</sup>	270 / 480 / 780 min <sup>-1</sup>	220 / 370 / 620 min <sup>-1</sup>	225 / 300 / 565 / 780 min <sup>-1</sup>
Drilling Capacity	Ø250 mm (10")	Ø300 mm (12")	Ø350 mm (14")	Ø400 mm (16")
Gear Oil Type	80W-90			
Gear Oil Capacity	625 ml			
Spindle Thread	1-1/4" UNC male & 1/2" BSP female			
Insulation Class	Class I with PRCD / GFCI (110-120V w/o PRCD / GFCI)			
Soft Start & Overload Protection	With			
Dimensions (LxWxH)	550 x 155 x 210 mm			
Weight	12.3 kg (27.1 lb)			13.5 kg (29.7 lb)
Characteristics / Certification				

# DM20 INTEGRATED HIGH-FREQUENCY DIAMOND CORE DRILL MOTOR

The water-cooled permanent magnet synchronous motor provides unprecedented power output efficiency on single phase supply for outstanding performance with large diameters up to 500 mm (20"). The 17-speed integrated controller allows a wide speed range with full torque available at every speed.









**Features**

1. Water-cooled PMSM motor has the highest output efficiency of any single phase coring motor on the market.
2. Conveniently runs directly on 230 V single phase supply. The power converter is integrated into the unit, and the automatic PRCD is built-in as well, so you can just plug it in and start drilling!
3. Oil bath gearbox with mechanical clutch. Due to the special motor characteristics which allow electronic speed selection with no loss of torque, only one mechanical ratio is needed.
4. Anti-seize ring to prevents core bits from getting stuck on the spindle.
5. Water feed inlet can be mounted on either side of the motor for operator convenience.
6. Easy to use operator interface.
7. The Ferro-Fix rebar assist button makes it much easier to handle embedded steel while drilling.
8. LED display gives bit diameter, as well as mode display, service indicator, hours counter, and error codes.
9. The separate LED load indicator lamp gives reliable information on load and thermal conditions.
10. The electronic speed selection with 17 diameter settings are easy to select, and can be adjusted on the fly. Can be easily changed between metric and inch display units.
11. Bit threading function makes threading on large heavy bits much easier. Simply align the spindle with the bit, press the button once, and it will automatically rotate at low speed to thread the bit on. Press the button once again to stop.

**Standard/ Optional Accessories See p. 55**

Model	DM20
Power Input	3700 W /16 A
Power Output Efficiency	90%
Voltage, Frequency	1~ 220-240 V, 50-60 Hz
Rated Load Speeds*	220 - 540 min <sup>-1</sup>
Electronic Speed Settings	17 steps
Drilling Capacity	Ø500 mm (20")
Soft Start & Overload Protection	With
Gear Oil Type	80W-90
Gear Oil Capacity	400 ml
Spindle Thread	1-¼" UNC
Insulation Class	Class I with PRCD
Ingress Protection Class	IP55
Dimensions (LxWxH)	669 x 221 x 182 mm
Weight	16.7 kg (36.7 lb)
Characteristics / Certification	   

\* Due to the constant speed motor design, the no load speeds and rated load speeds are the same.



# Dry Drilling Accessories

## DM51 Dry Diamond Core Drill Motor

Standard Accessories	
Side Handle	
Percussion Selector	
Optional Accessories	
Soft-Grip Side Handle	



**a** SDS Pilot Drill Socket

## DM52 Diamond Core Drill Motor

Standard Accessories	
Side Handle	
Water Feed Adaptor Head	
Vacuum Adaptor Head	
<b>b</b> PRCD / GFCI Interrupter	
Optional Accessories	Part Number
Soft-Grip Side Handle	
<b>a</b> SDS Pilot Drill Socket	302-04387-907-001



**b** PRCD / GFCI Interrupter



**c1** Centering Pilot

## DME51, DME52 Dry Diamond Core Drill Motors

Standard Accessories	
Side Handle	
Optional Accessories	Part Number
<b>e</b> M18 to M16 Spindle Adaptor	302-04311-903-009
Vacuum Collector Pad Set (See p.54)	
<b>c1</b> Centering Pilot for L 85 mm bits	0202-0111-00000-014
<b>c1</b> Centering Pilot for L 65 mm bits	0202-0111-00000-015
<b>d</b> External Dust Extractor Head (for banana slot bits)	
M16 female to M16 male	0299-0295-00000-016
M18 female to M18 male	0299-0295-00000-012
M18 female to M16 male	0299-0295-00000-011
(choose desired thread when ordering)	



**c2** L 300 mm Centering Pilot



**d** External Dust Extractor Head  
(Three thread types available)

## DM62, DD62, DD160 Dry Diamond Core Drill Motors

Standard Accessories	
Blow Molded Case	
Side Handle	
M32 Wrench	
Optional Accessories	Part Number
<b>c2</b> Centering Pilot for L 300 mm Bits	0202-0111-00000-001



**e** M18 to M16 Spindle Adaptor

# DM52, DM62, DD62, DD160, DMC6, DMC160

## Dry Drilling Accessories

ADD quick release dry drilling equipment			Part Number
①	Centering pilot, ADD		0202-0111-00000-013
②	Extension 200 mm		0299-0114-00000-006
③	ADD quick release		0299-0114-00000-007
④	1-1/4" to ADD M42 Adaptor		301-03022-000-005
Dry Diamond Core Bits with ADD M42 Coupling			Part Number
Diameter(mm)	Coupling	Useful Length(mm)	
56	ADD	200	305-91042-200-056
68	ADD	200	305-91042-200-068
82	ADD	200	305-91042-200-082
102	ADD	200	305-91042-200-102
112	ADD	200	305-91042-200-112
132	ADD	200	305-91042-200-132
162	ADD	200	305-91042-200-162
172	ADD	200	305-91042-200-172
182	ADD	200	305-91042-200-182
M16 dry drilling equipment			Part Number
⑤	Centering Pilot		0202-0111-00000-008
⑥	M16 Dust Extractor (for banana slot bits)		0299-0114-00000-008
⑦	1-1/4" to M16 Adaptor		301-03022-000-005
Dry Diamond Core Bits with M16 Coupling			Part Number
Diameter(mm)	Coupling	Useful Length(mm)	
68	M16	85	305-91016-085-068
82	M16	85	305-91016-085-082
102	M16	85	305-91016-085-102
112	M16	85	305-91016-085-112

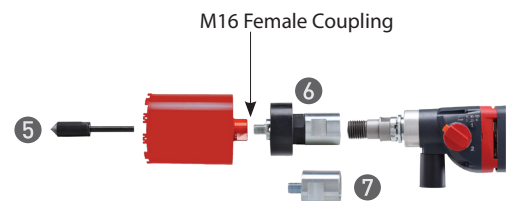
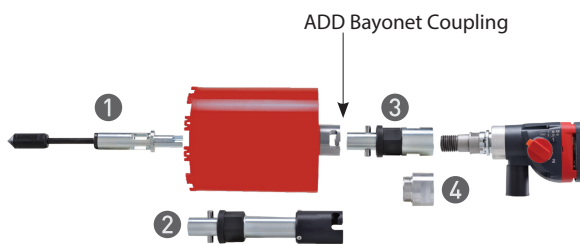

Dry-Type Diamond Core Bits (For models with M16 coupling)		
Diameter (mm)	Part Number 150 mm Length	Part Number 250 mm Length
32	305-03356-004-068	305-03356-004-108
38	305-03356-004-069	305-03356-004-109
42	305-03356-004-070	305-03356-004-110
52	305-03356-004-071	305-03356-004-111
62	305-03356-004-072	305-03356-004-112
65	305-03356-004-073	305-03356-004-113
72	305-03356-004-074	305-03356-004-114
78	305-03356-004-075	305-03356-004-115
82	305-03356-004-076	305-03356-004-116
86	305-03356-004-077	305-03356-004-078



# Wet / Dry Drilling Accessories

## DMC160 Wet / Dry Diamond Core Drill Motors

Standard Accessories	
Side Handle	
Water Supply Kit	
M32 Wrench	
<b>b</b> PRCD / GFCI Interrupter	
<b>f</b> Brass Claw-Type Couplings	
Optional Accessories	Part Number
Soft-Grip Side Handle	
<b>a</b> SDS Pilot Drill Socket	302-04387-907-001
<b>c2</b> Centering Pilot for L 300mm Bits	0202-0111-00000-001



**a** SDS Pilot Drill Socket



**b** PRCD / GFCI Interrupter

## DMC6 Wet / Dry Diamond Core Drill Motors

Standard Accessories	
Side Handle	
Water Supply Kit	
M32 Wrench	
<b>b</b> PRCD / GFCI Interrupter	
<b>f</b> Brass Claw-Type Couplings	
Optional Accessories	Part Number
Soft-Grip Side Handle	
<b>a</b> SDS Pilot Drill Socket	302-04387-907-001
<b>c2</b> Centering Pilot for L 300mm Bits	0202-0111-00000-001



**c2** L 300 mm Centering Pilot



**f** Brass Claw-Type Couplings

# Wet Drilling Accessories

## DM2 Wet Diamond Core Drill Motors

Standard Accessories	
Side Handle	
Water Supply Kit	
<b>b</b> PRCD / GFCI Interrupter	
Optional Accessories	Part Number
Soft-Grip Side Handle	



**a** SDS Pilot Drill Socket

## DM5 Wet Diamond Core Drill Motors

Standard Accessories	
Blow Molded Case	
Side Handle	
Water Supply Kit	
<b>b</b> PRCD / GFCI Interrupter	
Optional Accessories	Part Number
Soft-Grip Side Handle	
<b>a</b> SDS Pilot Drill Socket	302-04387-907-001



**b** PRCD / GFCI Interrupter

## DM6 Wet Diamond Core Drill Motors

Standard Accessories	
Side Handle	
Water Supply Kit	
M32 Combination Wrench	
<b>b</b> PRCD / GFCI Interrupter	
Optional Accessories	Part Number
Soft-Grip Side Handle	
<b>a</b> SDS Pilot Drill Socket	302-04387-907-001

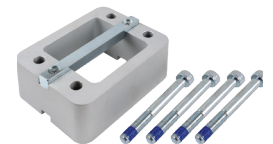

**g** 40 mm Spacer Kit

## DM8P Wet Diamond Core Drill Motor

Standard Accessories	
Blow Molded Case	
Side Handle	
Water Supply Kit	
M32 Wrench	
<b>b</b> PRCD / GFCI Interrupter	

## DM9, 10, 12 , 14 Diamond Core Drill Motors

Standard Accessories	
Water Supply Kit	
<b>b</b> PRCD / GFCI Interrupter	
Remark: 110-120V W/O PRCD / GFCI	
Optional Accessories	Part Number
<b>g</b> 40 mm Spacer Kit	0299-0214-0000-001

## DM20 High Frequency Diamond Core Drill Motor

Standard Accessories	
Water Supply Kit	
Optional Accessories	Part Number
<b>g</b> 40 mm Spacer Kit	0299-0214-0000-001

# Drilling Accessories

Drilling Series Optional Accessories	Part Number
<b>a</b> SDS Pilot Drill Socket (for models with female 1/2" BSP spindles)	302-04387-907-001
<b>h</b> Acme Thread Adaptor (Adapts 1-1/4"-7 UNC spindles to 1-1/4"-3 Acme)	302-04311-901-002
<b>i</b> M16 Dry Arbor Adaptor (Adapts 1-1/4"-7 UNC spindles to M16-2.0)	302-04311-000-002



**a** SDS Pilot Drill Socket

Vacuum Collector Pad	Part Number
<b>j</b> Vacuum Collector Pad Set (small, max. 82 mm) *Set includes pad + 4 rings	0299-0113-00000-002
<b>k</b> Vacuum Collector Pad Set (large, max. 150 mm) *Set includes pad + 2 rings	0299-0113-00000-001
<b>l</b> Ring (Ø45) - for small pad	303-02034-004-003
Ring (Ø55) - for small pad	303-02034-004-004
Ring (Ø65) - for small pad	303-02034-004-005
Ring (Ø75) - for small pad	303-02034-004-006
<b>m</b> Ring (Ø110) - for large pad	303-02034-004-001
Ring (Ø130) - for large pad	303-02034-004-002

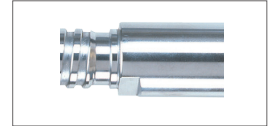

**h** Acme Thread Adaptor

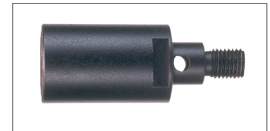

**i** M16 Dry Arbor Adaptor

# Special Clutch Tools

Torque Wrench Adapter Socket (for checking the clutch's slipping torque)	Part Number
For DD160, DD62, DM62, DMC6D/P, DMC160	0202-0117-00000-010
For DM52D, DME51D, DME52D	0202-0117-00000-011
<b>n</b> For DM12, DM14	0202-0117-00000-013
For DM2	0202-0117-00000-014
For DM8P	0202-0117-00000-015
For DM20	0202-0117-00000-017



**j** Vacuum Collector Pad (small)



**k** Vacuum Collector Pad (large)

Holding Fixture for adjusting clutches (to safely hold the shaft without damaging it)	Part Number
For DM52D, DME51D, DME52D	0202-0117-00000-001
For DMC6D/P, DMC160	0202-0117-00000-002
For DM12	0202-0117-00000-003
For DM14	0202-0117-00000-004
<b>o</b> For DM2	0202-0117-00000-006
For DD160	0202-0117-00000-007
For DD62, DM62	0202-0117-00000-008
For DM8P	0202-0117-00000-009
For DM20	0202-0117-00000-016

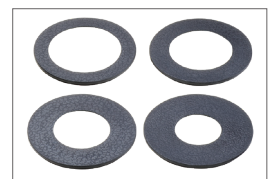

**l** Ring Set (Ø45~Ø75)



**m** Ring Set (Ø110~Ø130)



**n** Torque Wrench Adapter Socket

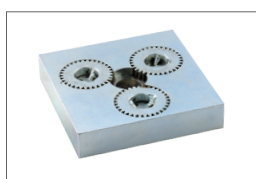

**o** Holding Fixture for adjusting clutches

# 1-Piece Wet-Type Diamond Core Bits (For models with 1-1/4"-7 UNC spindles)

450mm Length (1-1/4"-7 UNC Coupling)			
Diameter (mm)	Segment Dimensions (mm)		Part Number
	Height x Thickness & Number of Segments		
25	H 9 x T 3.2 - single seg.		305-03356-004-034
32	H 9 x T 3.2 - single seg.		305-03356-004-035
38	H 9 x T 3.2 - single seg.		305-03356-004-036
42	H 9 x T 3.2 - single seg.		305-03356-004-037
52	H 10 x T 3.5 - 5 seg.		305-03356-004-038
56	H 10 x T 3.5 - 5 seg.		305-03356-004-039
62	H 10 x T 3.5 - 5 seg.		305-03356-004-040
65	H 10 x T 3.5 - 6 seg.		305-03356-004-041
72	H 10 x T 3.5 - 6 seg.		305-03356-004-042
76	H 10 x T 3.5 - 7 seg.		305-03356-004-043
82	H 10 x T 3.5 - 7 seg.		305-03356-004-044
86	H 10 x T 3.5 - 7 seg.		305-03356-004-045
92	H 10 x T 3.5 - 8 seg.		305-03356-004-046
102	H 10 x T 3.5 - 9 seg.		305-03356-004-047
112	H 10 x T 3.5 - 10 seg.		305-03356-004-048
122	H 10 x T 3.5 - 10 seg.		305-03356-004-050
127	H 10 x T 3.5 - 10 seg.		305-03356-004-051
132	H 10 x T 3.5 - 10 seg.		305-03356-004-052
142	H 10 x T 3.5 - 11 seg.		305-03356-004-053
152	H 10 x T 4.0 - 12 seg.		305-03356-004-054
162	H 10 x T 4.0 - 12 seg.		305-03356-004-055
172	H 10 x T 4.0 - 13 seg.		305-03356-004-056
182	H 10 x T 4.0 - 13 seg.		305-03356-004-057
200	H 10 x T 4.0 - 14 seg.		305-03356-004-058
203	H 10 x T 4.0 - 14 seg.		305-03356-004-059
226	H 10 x T 4.5 - 15 seg.		305-03356-004-060
232	H 10 x T 4.5 - 16 seg.		305-03356-004-061
252	H 10 x T 4.5 - 16 seg.		305-03356-004-062
300	H 10 x T 5.0 - 20 seg.		305-03356-004-063
305	H 10 x T 5.0 - 20 seg.		305-03356-004-064
332	H 10 x T 5.0 - 22 seg.		305-03356-004-065
356	H 10 x T 5.0 - 24 seg.		305-03356-004-066
<b>Special Core Bit for Asphalt:</b>			
102	H 10 x T 4.0 - 9 seg.		305-03356-004-067



# S170 / AS200 / NS250 / S350 / S500 / S800 Diamond Core Drill Stands

**S800**

Aluminum column with steel inserts for maximum rigidity and minimum weight

Convenient, tool-free carriage lock lever

Quick mount Dovetail cradle for fast motor fixing

Motor Mounting Plate supplied as standard equipment:

NS250 & S350      S500 & S800

Crank Handle doubles as a wrench

Heavy gauge steel base with lightening holes for optimum stability and vibration resistance

Wheels for easy transport

Optional: Fixing Kit for use with M12 drop-in anchors: Includes stud, washer, and speed nut (drop-in anchors not included)

Optional: Anchoring Plate (necessary with steel-base models: AS200, S170, NS250, S350, S500, S800)

0~45°

S800 and S500 include a second crank spindle with reduction gearing for decreased effort

AS200 folds down completely for easy storage



Model	S170	AS200	NS250	S350	S500	S800
Capacity w/o extension spacers (mm)	Ø170 (7")	Ø202 (8")	Ø250 (10")	Ø350 (14")	Ø350 (14")	Ø400 (16")
Max. Capacity with extension spacers (mm)	-	-	-	-	Ø500 (20")	Ø800 (32")
Effective Stroke (mm)	540	590	660	660	690	760
Dimensions (LxWxH) (mm)	460 x 215 x 815	361 x 250 x 890	400 x 245 x 984	390 x 248 x 970	480 x 240 x 1025	555 x 275 x 1035
Weight (Not Including crank handle)	10.1 kg (22.3 lb)	10.5 kg (23.1 lb)	14.9 kg (31.7 lb)	14.4 kg (31.7 lb)	19.1 kg (42.0 lb)	26.5 kg (58.4 lb)

# QS600 Diamond Core Drill Stand

Large Capacity  
Fits up to 500 mm bits without needing to use any extension spacer.

Optional:  
50 mm Extension Spacer Kit allows drilling up to Ø 600 mm



Wrench Stop Lug  
For safely loosening tight core bits

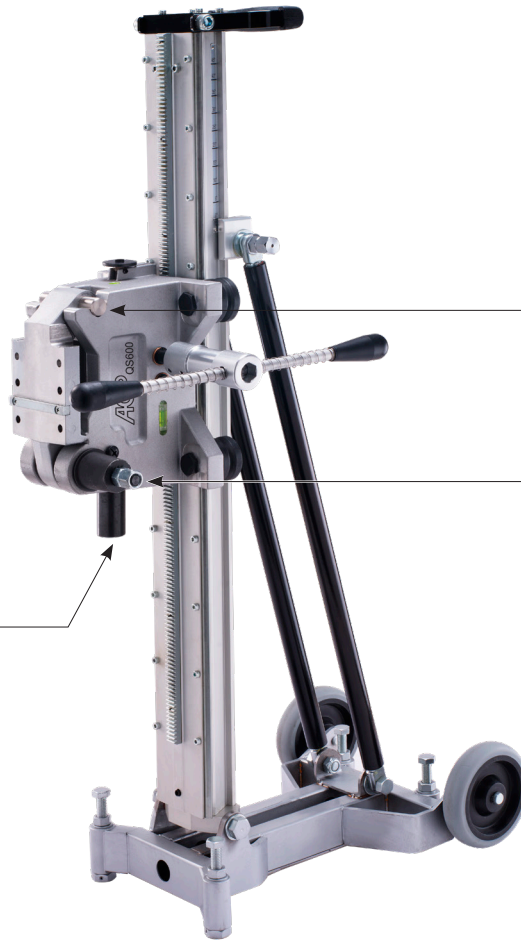

Quick-Release Cam-Lock Cradle  
Makes it easy to mount and remove the motor, even in difficult positions.



Dual Gear Ratio Feed on Both Sides  
One ratio for fast motion, and the other slow ratio for decreased operator effort



Self-Centering M19 Crank Handle  
Gives more leverage when extended and is convenient to use as a wrench for all of the M19 control elements.



Convenient Features  
Pin-type carriage lock  
Built-in horizontal & vertical spirit levels  
Cable clip

Model	QS600
Capacity w/o extension spacers (mm)	Ø500 (20")
Max. Capacity with extension spacers (mm)	Ø600 (24")
Effective Stroke (mm)	670
Dimensions (LxWxH) (mm)	582 x 313 x 1032
Weight (Not Including crank handle)	26.8 kg (59 lb)



# Diamond Core Drill Stand Accessories

## ■ Laser Aiming Devices

Especially useful when creating accurately aligned holes through multiple walls for pipe passes.

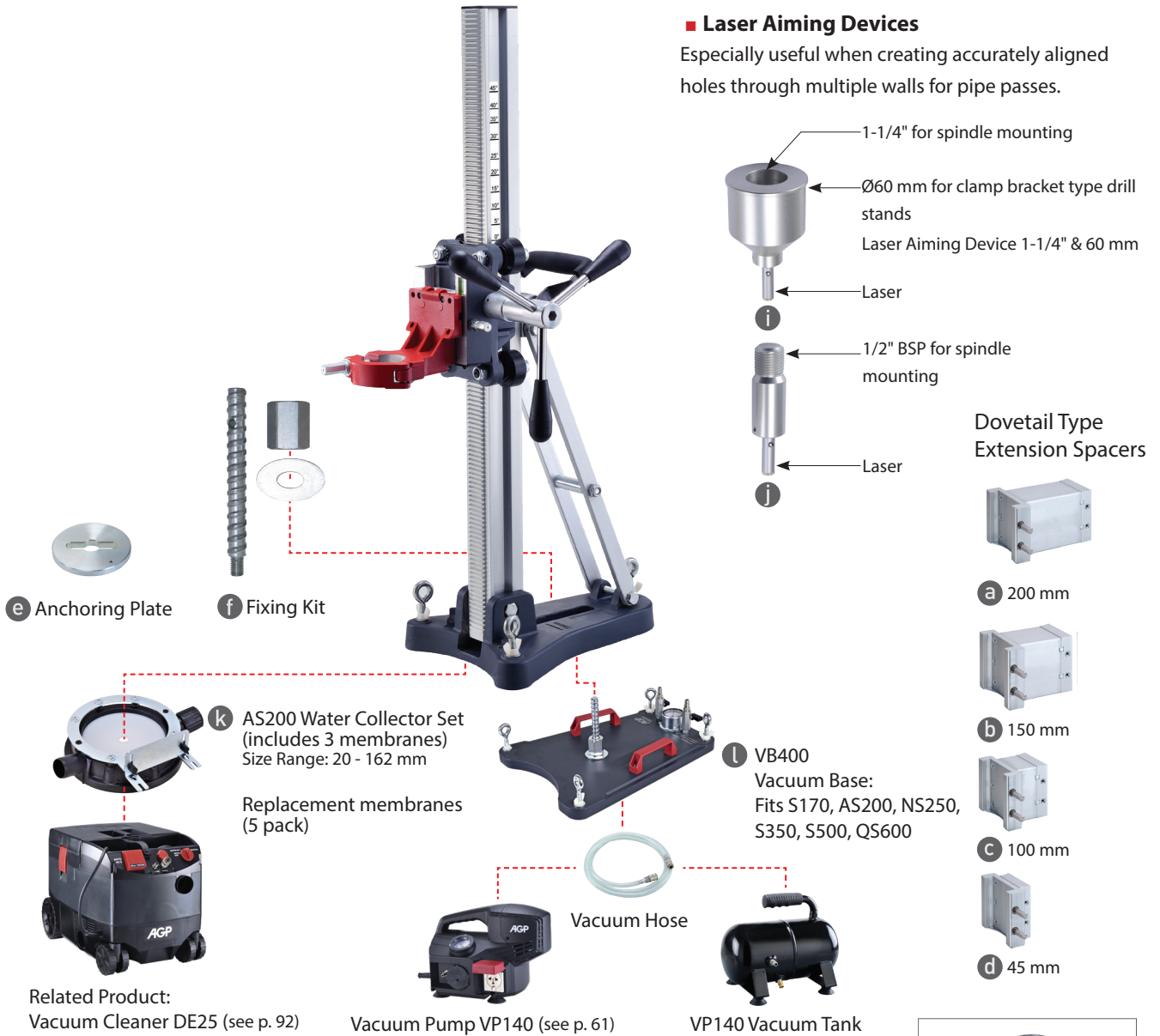

**e** Anchoring Plate

**f** Fixing Kit

**k** AS200 Water Collector Set (includes 3 membranes) Size Range: 20 - 162 mm

Replacement membranes (5 pack)

**l** VB400 Vacuum Base: Fits S170, AS200, NS250, S350, S500, QS600

Vacuum Hose

Dovetail Type Extension Spacers

**a** 200 mm

**b** 150 mm

**c** 100 mm

**d** 45 mm

Related Product: Vacuum Cleaner DE25 (see p. 92)

Vacuum Pump VP140 (see p. 61)

VP140 Vacuum Tank

### Optional Accessories

### Part Number

<b>a</b> Extension Spacer 200 mm	0299-0159-00000-004
<b>b</b> Extension Spacer 150 mm	0299-0159-00000-003
<b>c</b> Extension Spacer 100 mm	0299-0159-00000-002
<b>d</b> Extension Spacer 45 mm	0299-0159-00000-001
<b>e</b> Anchoring Plate	302-04464-903-001
<b>f</b> Fixing Kit	0299-0252-0000-001
<b>g</b> Jack Screw for S500	302-04178-907-001
<b>g</b> Jack Screw for S800	302-04178-907-003
<b>h</b> Front Handle Set for S500	0299-0211-0000-001
<b>i</b> Laser Aiming Device 1-1/4" & 60 mm	0299-0261-00000-001
<b>j</b> Laser Aiming Device 1/2" BSP	0299-0261-00000-002
<b>k</b> AS200 Water Collector Set (includes 3 membranes) Size Range: 20 - 162 mm	0299-0249-0004-001
Replacement membranes (5 pack)	0299-0250-0004-001
<b>l</b> VB400 Vacuum Plate (Fits S170, AS200, NS250, S350, S500, QS600)	0299-0143-00000-026
<b>m</b> 60 mm Clamp Bracket (except S170, AS200)	0299-0159-00000-005



**g** Jack Screw



**h** Front Handle Set



**m** 60 mm Clamp Bracket

# VP140 VACUUM PUMP

A vacuum pump specifically designed for use with power tools which are anchored by a vacuum base.



4 Air Hose, 2.5 M

VP140 Vacuum Pump

7 Vacuum Tank

VB400 Vacuum Base  
See p. 60

Mag Drill Vacuum Base  
See p. 113

## Features

1. Integrated Switching Socket only supplies power to tool when sufficient vacuum is achieved.
2. Warning Buzzer sounds when vacuum is insufficient.
3. Vacuum Gauge alerts operator to vacuum status.
4. Quick-Release Fittings for faster set up.
5. Water Separator for draining out water from the system.
6. Safety Reset Button to energize the connected power tool.
7. Optional Vacuum Tank provides an added layer of safety.

Model	VP140
Power Input	200 W
Voltage, Frequency	220-240 V~ 50-60 Hz or 110-120 V~ 50-60 Hz
Air Flow	30.5 l/min (1.07 cfm)
Max Vacuum	-0.9 bar (-13 psi)
Ingress Protection	IPX4
Dimensions (LxWxH)	310 x 238 x 250 mm
Weight	6.7 kg (14.8 lb)
Characteristics / Certification	<b>CE CB</b>

<b>Standard Accessories</b>
Air Hose, 2.5 M
<b>Optional Accessories</b>
Vacuum Tank (Includes Air Hose, 1 M)