



AGP[®]

**2025
EUROPE
PRODUCT
CATALOG
METAL WORKING**



Our History

In 1989, AGP started as a 2-person family company producing small power tools for the Taiwanese market. With the years of dedication and the constant expansion to new markets, we have grown to be an international organization with over 180 skilled employees which is currently distributing products on 6 continents. AGP Taiwan serves as the design and manufacturing center for global markets. We export over 60% of our products to European market. Since 2017, the sales and distribution of AGP products in the European market are organized by AGP Europe, located in Erpe Mere, Belgium.

Interesting Fact

AGP comes from All Get Profit, as simple as it sounds, it symbolizes the values the founders of AGP keep, which are to be always mindful of all stakeholders within the entire business, including our suppliers and our customers.

BRAND VISION

We Harness The Power of Technology, Enabling You to Achieve.

BRAND MISSION

We Focus on Concrete Matters and Real Needs,
Innovating Power Tools for The Toughest Demands.



R&D Capabilities

With designers and engineers of unique backgrounds and a strategic R&D decision process, we transform new concepts into working power tools faster than most, providing advantages to our customers by greatly shortening the time frame to bring a new tool to market.

Consistent High Quality and Flexibility

From in-house design and certified testing capabilities, to sourcing and production, we control each stage of the production process. This integration is key to maintaining consistent quality and maximum flexibility.

Responsive and Problem Solving

Industry experience, creativity, and a dynamic team means we can be responsive to market needs. We listen to user suggestions to create products which are most suitable to their given market. We constantly seek out feedback from end users to find the best solutions to fit their needs.

Global Service

AGP customers can receive their products fast, safely and smoothly, thanks to the close collaboration with our distribution network in various countries. Find high-quality drill motors, drill stand, saws, concrete grinders, wall chasers, drywall sanders and vacuum cleaners from our distributors.



Product Index

Magnetic Core Drills



Auto-Reverse Tapping Magnetic Core Drill	TP2000	
Low Profile Magnetic Core Drill	PMD3530	
1-Speed Magnetic Core Drills	SMD351L, SMD351H	P.05 - P.21
2-Speed Magnetic Core Drills	SMD352, SMD502, MD500/2	
4-Speed Magnetic Core Drills	MD750/4, MDS750/4, MD120/4	



Metal Saws

Metal Saws	CS320, DRC355	P.22 - P.25
------------	---------------	-------------



Hole Cutting Drill

Hole Cutting Drill	HC127	P.26 - P.27
--------------------	-------	-------------



Tapper

Tapper	T14	P.28
--------	-----	------

Key to symbols used this catalog:

Overload Protection	Soft Start	Double Insulation (Class II)	Number of Gears
Variable Speed	Forward & Reverse	Constant Speed	Plastic Carry Case
			Blow Molded Case

TP2000 MAGNETIC TAPPING & DRILLING MACHINE





PATENTED

A patented, versatile, 1100 W magnetic tapping & drilling machine. Specially designed, two-mode gearbox with one setting for tapping with auto-reverse, and another setting for standard drilling. Convenient quick-release Bilz no.2 type coupling system.

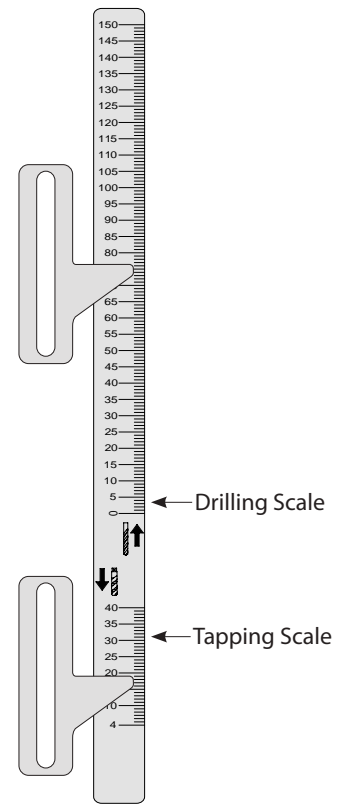

Depth Meter (for blind holes)



Model	TP2000
Power Input	1100 W
Voltage, Frequency	220-240 V~ 50-60 Hz, or 110-120 V~ 50-60 Hz
Tapping Mode: No / Full Load Speed min ⁻¹	150 (90) (350 in reverse)
Drilling Mode: No / Full Load Speed min ⁻¹	550 (330)
Spindle Coupling	31 mm (Bilz no. 2)
Annular Cutter Arbor	Set Screw Type, 19.05 mm (3/4") Weldon Shank
Capacity, Taps: Ø	20 mm (13/16")
Capacity, Cutters: Ø x Depth of Cut	35 mm x 50 mm (1-3/8" x 2")
Capacity, Twist Drills (≤ 1/2" shank): Ø x Depth of Cut	13 mm x 150 mm (1/2" shank x 6")
Magnetic Adhesion	15,000 N
Net Weight	14.5 kg (32.0 lb)
Characteristics / Certification	   

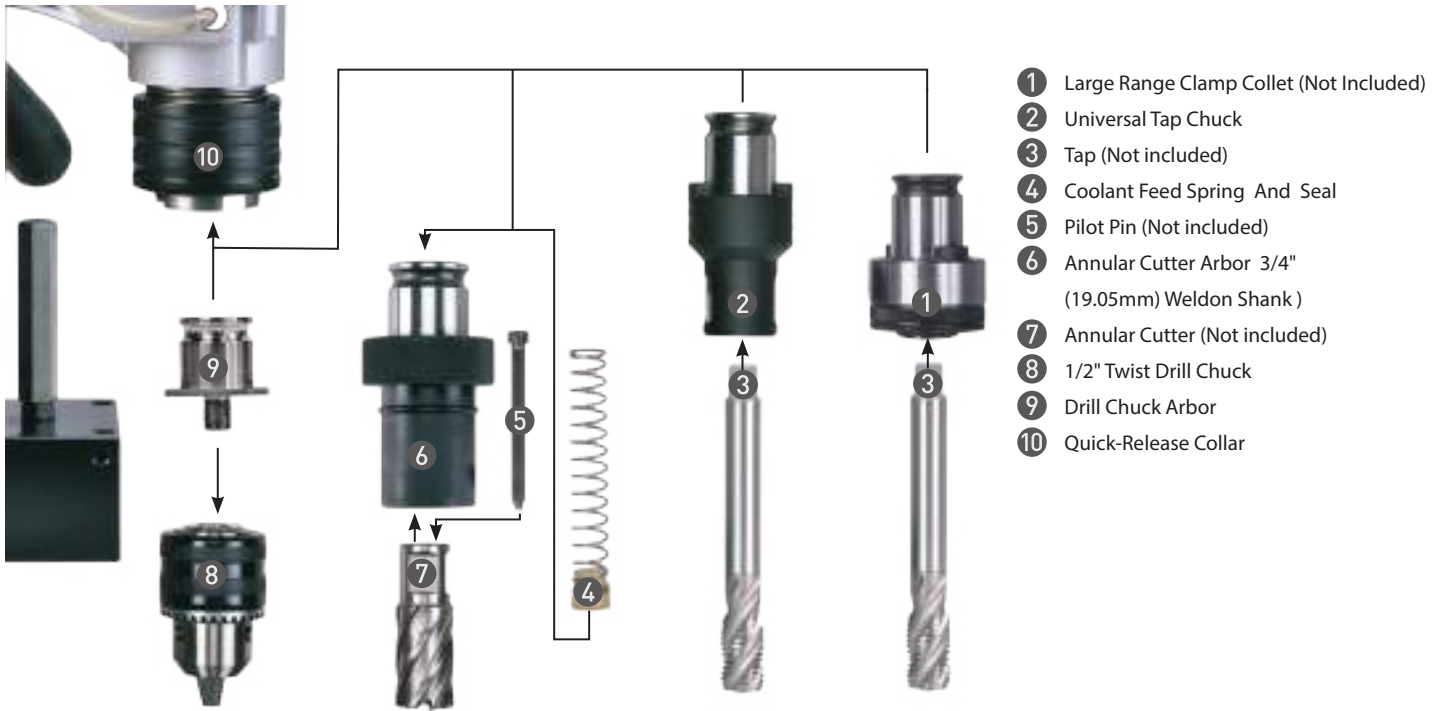

- ① Large Range Clamp Collet (Not Included)
- ② Universal Tap Chuck
- ③ Tap (Not included)
- ④ Coolant Feed Spring And Seal
- ⑤ Pilot Pin (Not included)
- ⑥ Annular Cutter Arbor 3/4" (19.05mm) Weldon Shank
- ⑦ Annular Cutter (Not included)
- ⑧ 1/2" Twist Drill Chuck
- ⑨ Drill Chuck Arbor
- ⑩ Quick-Release Collar

Mode Selector

Auto-Reverse Tapping Mode

Drilling Mode

Tapping Mode

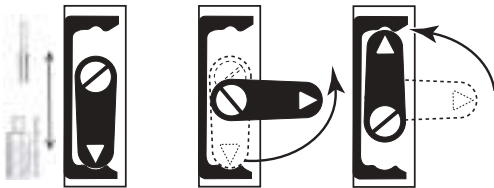

Annular Cutter Arbor
(Annular cutter and pilot pin not included)



Drill Chuck Arbor

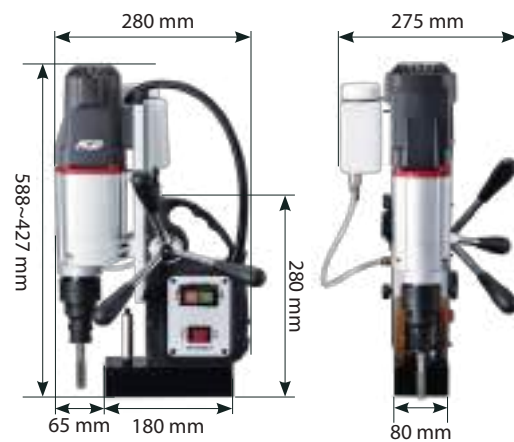

Features

1. 2 mode gear box for optimized torque and cutting speed.
2. Mode Selector for shifting between Auto-Reverse Tapping Mode or Standard Drilling Mode.
3. The Quick-Release arbor makes it quick and tool-free to change cutters and accessories.
4. Depth Meter.
5. Travel Limiter Stop.

Standard/Optional Accessories See p. 16

PMD3530 LOW PROFILE MAGNETIC DRILL

A low-profile single speed 1100 W magnetic drilling machine for up to Ø 35 x 35 mm standard sized cutters. It's compact size fits into 198 mm vertical spaces. The LED work light is very useful in dark work areas.



Model	PMD3530
Power Input	1100 W
Voltage, Frequency	220-240 V~ 50-60 Hz, or 110-120 V~ 50-60 Hz
No Load (Rated Load) Speed min ⁻¹	650 (390)
Max. Capacity Ø x Depth of Cut	35 mm x 35 mm (1-3/8" x 1-3/8")
Cutter Shank	19.05 mm (3/4") Weldon
Magnetic Adhesion	15,000 N
Net Weight	10.5 kg (23.2 lb)
Characteristics / Certification	

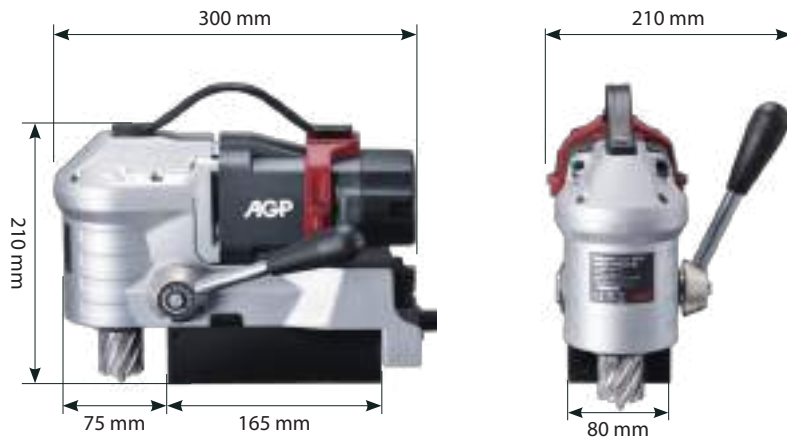

Features

1. 1 speed gear box for optimized torque and cutting speed.
2. The Quick-Release arbor makes it quick and tool-free to change cutters and accessories.
3. The adjustable tool-free lever can mount on either side.
4. LED light for working in dark space.
5. Ergonomic handle for convenient carrying.

Standard/Optional Accessories See p. 16

SMD351L & SMD351H

VARIABLE SLIDE MAGNETIC DRILLS WITH QUICK-RELEASE ARBOR

Single speed 1100 W magnetic drilling machines with quick-release arbor and adjustable slide height. The speed of the SMD 351L is optimized for HSS cutters up to Ø 42 x 50 mm and the SMD 351H is optimized for TCT cutters up to Ø 35 x 50 mm. Both are capable of twist drilling up to 1/2" shank.



Features

1. A versatile and economical tool that fulfills the needs of most operators.
2. The quick-adjustable variable height slide allows quick conversion between cutters and twist drills. Lower for cutters, raise for twist drills.
3. The Quick-Release arbor makes it quick and tool-free to change cutters and accessories.

Standard/Optional Accessories See p. 16

Model	SMD351L	SMD351H
Power Input	1100 W	
Voltage, Frequency	220-240 V~ 50-60 Hz, or 110-120 V~ 50-60 Hz	
No / Full Load (Rated Load) Speed min ⁻¹	450 (270)	730 (440)
Max. Capacity	Ø x Depth of Cut of Cutters	
	SMD351L: 42 x 50 mm (1-5/8" x 2") SMD351H: 35 x 50 mm (1-3/8" x 2")	
	Ø Twist Drills	
	≤ 1/2" shank	
	Stroke	
	140 mm (5-1/2")	
Overload Protection	With	
Magnetic Adhesion	15,000 N	
Net Weight	12.6 kg (27.7 lb)	
Characteristics / Certification		

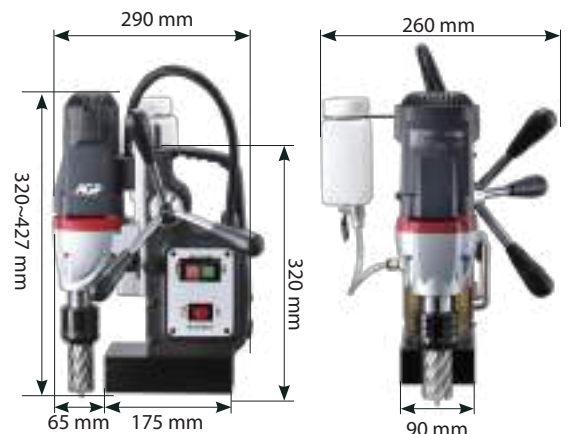

SMD352 & SMD502

TWO SPEED, VARIABLE SLIDE MAGNETIC DRILLS WITH QUICK-RELEASE ARBOR

2 speed 1100 W magnetic drilling machine with quick-release arbor and adjustable slide height. Choose the SMD 352 for cutters up to Ø 42 x 50 mm and the SMD 502 for cutters up to Ø 50 x 50 mm. Both are capable of twist drilling up to 1/2" shank.



Features

1. 2 speed gear box for optimized torque and cutting speed for a wide range of cutting tools.
2. The quick-adjustable variable height slide allows quick conversion between cutters and twist drills. Lower for cutters, raise for twist drills.
3. The Quick-Release arbor makes it quick and tool-free to change cutters and accessories.

Standard/Optional Accessories See p. 17

Model	SMD352	SMD502
Power Input	1100 W	
Voltage, Frequency	220-240 V~ 50-60 Hz, or 110-120 V~ 50-60 Hz	
No / Full Load (Rated Load)	Speed 1 450 (270)	300 (180)
Speed min ⁻¹	Speed 2 730 (440)	450 (270)
Max. Capacity	Ø x Depth of Cut of Cutters SMD352: 42 mm x 50 mm (1-3/8" x 2") SMD502: 50 mm x 50 mm (2" x 2")	
	Ø Twist Drills ≤ 1/2" shank	
	Stroke 140 mm (5-1/2")	
Overload Protection	With	
Magnetic Adhesion	15,000 N	17,000 N
Net Weight	13.1 kg (28.8 lb)	14.8 kg (32.6 lb)
Characteristics / Certification		

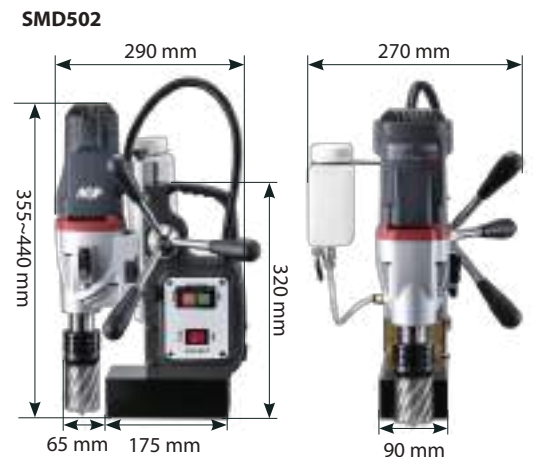

MD500/2 2-SPEED LONG-CUTTER MAGNETIC DRILL

A 2 speed 2000 W magnetic drilling machine for cutters up to Ø65 x 75 mm L and twist drills up to 16 mm (5/8") shank. Features extra long cutter capacity.



Features

1. 2 speed gear box for optimized torque and cutting speed for a wide range of cutting tools.
2. Extra Long Cutter Capacity.
3. Arbor Support Bracket.
4. The Quick-Release arbor makes it quick and tool-free to change cutters and accessories.

Standard/Optional Accessories See p. 17

Model	MD500/2	
Power Input	2000 W (220 V), 1700 W (110 V)	
Voltage, Frequency	220-240 V~ 50-60 Hz, or 110-120 V~ 50-60 Hz	
No / Full Load (Rated Load) Speed min ⁻¹	Speed 1	380 (230)
	Speed 2	550 (330)
	Ø x Depth of Cut of Cutters	65 mm x 75 mm (2-9/16" x 3")
Max. Capacity	Ø Twist Drills	≤ 16 mm (5/8") shank
	Stroke	115 mm (4-1/2")
Overload Protection	With	
Magnetic Adhesion	32,000 N	
Net Weight	21.1 kg (46.5 lb)	
Characteristics / Certification		

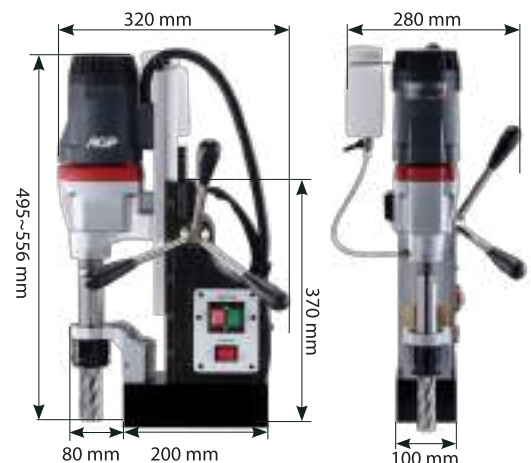

MD750/4

4 SPEED, MT3 MAGNETIC DRILLING & TAPPING MACHINE

MDS750/4

4 SPEED, MT3 SWIVEL BASE MAGNETIC DRILLING & TAPPING MACHINE

4-speed 2000 W heavy-duty magnetic drilling machine for cutters up to Ø 75 x 50 mm, twist drills up to 32 mm, and taps up to 25.4 mm. The MT3 arbor can also fit many other types of cutting tools. MDS750/4 features swivel Base for difficult to reach areas.



MD750/4

MDS750/4

Model	MD750/4	MDS750/4
Power Input	2000 W (220-240 V), 1700 W (110-120 V)	
Voltage, Frequency	220-240 V~ 50-60 Hz, or 110-120 V~ 50-60 Hz	
No Load (Rated) Speed min ⁻¹	Speed 1	150 (90)
	Speed 2	200 (120)
	Speed 3	300 (180)
	Speed 4	380 (230)
Max. Capacity	Ø x Depth of Cut of Annular Cutters	75 mm x 50 mm (3" x 2")
	Drill Chuck Capacity	≤ 16 mm (5/8") shank
Max. Capacity	Ø of MT3 Twist Drill	32 mm (1-1/4")
	Ø of Taps	25.4 mm (1")
	Stroke with MT3 Cutting Tools	145 mm (5-11/16")
Overload Protection	With	
Magnetic Adhesion	32,000 N	
Net Weight	24.4 kg (53.8 lb)	27.8 kg (61.3 lb)
Characteristics / Certification		

■ **Twist Drilling with Chuck**



MT3 Chuck Adaptor and Chuck (Optional)

■ **Twist Drilling**



MT3 Twist Drill Bit (Not included)

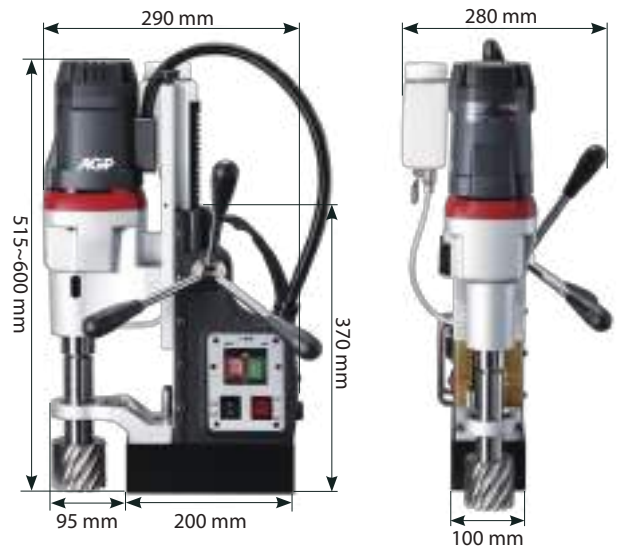

MD750/4

■ **Tapping Mode (Optional)**



MT3 #2 Range Tapping Chuck & Clamp Collet



MT3 #1 Range Tapping Chuck & Clamp Collet



Quick-Release Annular Cutter Arbor for cutters up to Ø 60mm

■ **SWIVEL BASE EQUIPPED MODELS (MDS750/4)** for difficult to reach areas

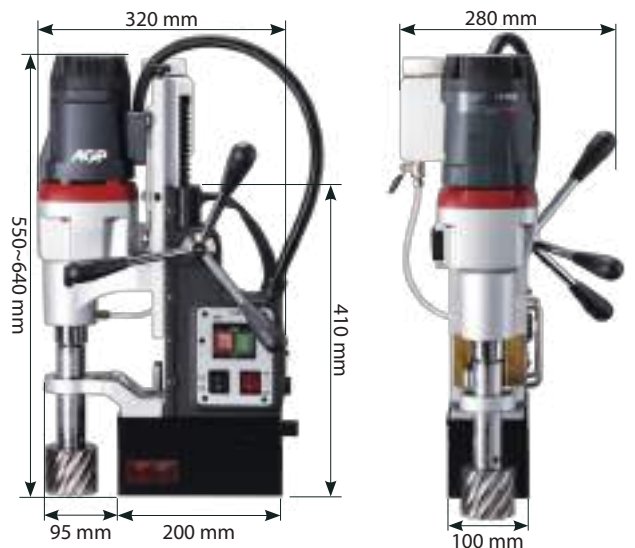
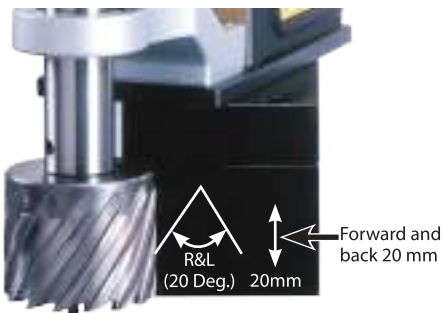

MDS750/4

Features

1. 4 speed gear box for optimized torque and cutting speed for a wide range of cutting tools.
2. Built-in cutting fluid system with unique through-the-spindle fluid feed.
3. Swivel Magnet Base Equipped for difficult to reach areas. (MDS750/4)
4. Reversing Switch for tapping.

Standard/Optional Accessories See p. 18

MD120/4

4 SPEED, MT3 MAGNETIC DRILLING & TAPPING MACHINE WITH VARIABLE SPEED

A 4-speed, 2000 W heavy-duty magnetic drilling machine for cutters up to Ø120 x 50 mm, twist drills up to 32 mm, and taps up to M32. The MT3 arbor can also fit many other types of cutting tools. The variable constant speed and sophisticated electronics allow optimized cutting speeds. The gearbox features a mechanical clutch for safety.



Model	MD120/4	
Power Input	2000 W (220-240 V), 1700 W (110-120 V)	
Voltage, Frequency	220-240 V~ 50-60 Hz, or 110-120 V~ 50-60 Hz	
* Rated Load Speed min-1	Speed 1	35-115
	Speed 2	70-210
	Speed 3	80-250
	Speed 4	140-450
Max. Capacity	Ø x Depth of Cut (with Set-Screw Type Cutter Arbor)	120 mm x 50 mm(4-3/4" x 2"), (100 mm (4") depth optional)
	Ø x Depth of Cut (with Quick-Release Cutter Arbor)	60 mm x 50 mm (2-3/8" x 2")
	Chuck Capacity	≤ 16 mm (5/8") shank
	Ø of MT3 Twist Drills	32 mm (1-1/4")
	Ø of Taps	32 mm (1-1/4")
	Stroke	215 mm (8-1/2")
	Max. Spindle Height	295 mm (11-5/8")
Overload Protection	With	
Magnetic Adhesion	32,000 N	
Net Weight	29.3 kg (64.6 lb)	
Characteristics / Certification		

* Due to the constant speed design, the no load and the rated load speeds are roughly the same.

■ Tapping Mode (Optional)



MT3 #2 Range
Tapping Chuck &
Clamp Collet



MT3 #1 Range
Tapping Chuck &
Clamp Collet



Quick-Release Annular
Cutter Arbor for cutters
up to Ø 60 mm



■ Twist Drilling with Chuck ■ Twist Drilling



MT3 Chuck Adaptor and 5/8"
Chuck (Not included)



MT3 Twist Drill Bit
(Not included)



Features

1. 4 speed gear box with mechanical clutch for optimized torque and cutting speed for a wide range of cutting tools.
2. Built-in cutting fluid system for cutters with unique through-the-spindle fluid feed.
3. Stepless variable speed wheel for electronic speed control with constant speed circuitry.
4. Reversing Switch for tapping.
5. Special MT3 high-torque tang drive spindle (mounts any MT3 accessory).

Standard/Optional Accessories See p. 19

Magnetic Drilling Accessories

TP2000 Magnetic Tapping & Drilling Machine

Standard Accessories	Part Number
Wrench M8	305-00302-004-001
L-Hex Key M2.5	305-00010-901-001
L-Hex Key M4	305-00010-901-002
Universal Tap Chuck	0202-0060-00000-012
Coolant Tank Kit	299-0007-00005-007
Annular Cutter Arbor 3/4" (19.05mm) Weldon Shank)	0202-0058-00907-002
1/2" Chuck And Chuck Key	305-00014-000-001
Drill Chuck Adaptor Arbor	0202-0059-00907-003
Chip Guard Kit	303-01007-000-003
Ratchet Strap	305-00034-004-002
Optional Accessories	
Tapping Chuck & Clamp Collet	See p. 20

PMD3530 Low Profile Magnetic Drill

Standard Accessories	Part Number
Ratchet Strap	305-00034-004-001
Chip Guard Kit	203-0094-00000-002

SMD351L & SMD351H

Variable Slide Magnetic Drills With Quick-Release Arbor

Standard Accessories	Part Number
Wrench M8	305-00009-000-001
L-Hex Key M2.5	305-00010-901-001
L-Hex Key M4	305-00010-901-002
T- Wrench M6	305-00004-901-002
Coolant Tank Kit	299-0007-00005-007
Ratchet Strap	305-00034-004-002
Chip Guard Kit	303-01007-000-003
Optional Accessories	
Quick-Release Chuck Adaptor	See p. 21
1/2" (13 mm) Chuck & Chuck Key	305-00014-000-001

SMD352 & SMD502

Two Speed, Variable Slide Magnetic Drills With Quick-Release Arbor

Standard Accessories	Part Number
Wrench M8	305-00302-004-001
L-Hex Key M2.5	305-00010-901-001
L-Hex Key M4	305-00010-901-002
T-wrench M6	305-00004-901-002
Coolant Tank kit	299-0007-00005-007
Ratchet Strap	305-00034-004-002
Chip Guard Kit	303-01007-000-003
Optional Accessories	
Quick-Release Chuck Adaptor	302-04240-901-001
1/2" (13 mm) Chuck & Chuck Key	305-00014-000-001

MD500/2 Long Cutter 2-Speed Magnetic Drill

Standard Accessories	Part Number
Wrench M8	305-00302-004-001
L-Hex Key M2.5	305-00010-901-001
Chip Guard Kit	303-01007-000-003
Coolant Tank Kit	299-0007-00005-007
Ratchet Strap	305-00034-004-002
Optional Accessories	
Chuck Adaptor	302-04020-901-014
5/8" (16 mm) Chuck & Chuck Key	305-00014-000-002

Magnetic Drilling Accessories

MD750/4

4 Speed, MT3 Magnetic Drilling & Tapping Machine

Standard Accessories	Part Number
MT3 Annular Cutter Arbor (set screw type)	302-04061-000-001
Wrench M8	305-00302-004-001
L-Hex Key M2.5	305-00010-901-001
L-Hex Key M4	305-00010-901-002
Chip Guard Kit	303-01007-000-003
Coolant Tank Kit	299-0007-00005-007
Ratchet Strap	305-00034-004-002
Drift	302-03022-903-001
Optional Accessories	
MT3 Chuck Adaptor	0202-0016-00000-001
5/8" (16 mm) Chuck & Chuck Key	305-00014-000-002
MT3 Tapping Adaptors	See p. 20
Tapping Attachments	See p. 20
MT3 Quick-Release Annular Cutter Arbor	See p. 20

MDS750/4

4 Speed, MT3 Swivel Base Magnetic Drilling & Tapping Machine

Standard Accessories	Part Number
MT3 Annular Cutter Arbor (set screw type)	302-04061-000-004
Wrench M8	305-00302-004-001
L-Hex Key M2.5	305-00010-901-001
L-Hex Key M4	305-00010-901-002
Chip Guard Kit	303-01007-000-003
Coolant Tank Kit	299-0007-00005-007
Ratchet Strap	305-00034-004-002
Drift	302-03022-903-001
Wrench M17	305-00009-000-002
Optional Accessories	
MT3 Chuck Adaptor	0202-0016-00000-001
5/8" (16 mm) Chuck & Chuck Key	305-00014-000-002
MT3 Tapping Adaptors	See p. 20
Tapping Attachments	See p. 20
MT3 Quick-Release Annular Cutter Arbor	See p. 20

MD120/4

4 Speed, MT3 Magnetic Drilling & Tapping Machine With Variable Speed

Standard Accessories	Part Number
Wrench M8	305-00302-004-001
L-Hex Key M2.5	305-00010-901-001
L-Hex Key M5	305-00010-901-004
Chip Guard Kit	302-03203-907-001
Coolant Tank Kit	299-0007-00005-012
Ratchet Strap	305-00034-004-002
Drift	302-03022-903-001
MT3 (1-1/4" Weldon) Annular Cutter Arbor, 50 mm depth (set screw type)	302-04061-000-005
MT3 (3/4" Weldon) Annular Cutter Arbor, 50 mm depth (set screw type)	302-04061-000-003
Optional Accessories	
MT3 Chuck Adaptor	0202-0016-00000-001
5/8" (16 mm) Chuck & Chuck Key	305-00014-000-002
MT3 Tapping Adaptors	See p. 20
Tapping Attachments	See p. 20
MT3 (3/4" Weldon) Quick-Release Annular Cutter Arbor, 50 mm depth	See p. 20
MT3 (1-1/4" Weldon) Annular Cutter Arbor, 100 mm depth, (set screw type)	See p. 20
MT3 (3/4" Weldon) Annular Cutter Arbor, 75 mm depth, (set screw type)	See p. 20



Magnetic Drilling Accessories

MD750/4, MDS750/4, MD120/4 Tapping Attachments

MT3 #1 Range Tapping Chuck & #1 Range Clamp Collets

MT3 Small Range Tapping Chuck (For Clamp Collets 3 ~ 15mm) **302-04293-901-001**

Clamp Collets				Clamp Collets			
Nominal Tap	Shank	Size of	Part Number	Nominal Tap	Shank	Size of	Part Number
Sizes:	Dia.:	Square:		Sizes:	Dia.:	Square:	
M3-JIS	4.0	3.2	305-00155-000-001	UNC1/2-JIS	9.0	7.0	305-00155-000-041
M4-JIS	5.0	4.0	305-00155-000-002	M3.5-DIN376	2.5	2.1	305-00155-000-015
M5-JIS	5.5	4.5	305-00155-000-003	M4-DIN376	2.8	2.1	305-00155-000-016
M6-JIS	6.0	4.5	305-00155-000-004	M4.5 / M5 -DIN376	3.5	2.7	305-00155-000-017
M7/M8-JIS	6.2	5.0	305-00155-000-005	M6-DIN376	4.5	3.4	305-00155-000-019
M9/M10-JIS	7.0	5.5	305-00155-000-006	M7-DIN376	5.5	4.3	305-00155-000-020
M11-JIS	8.0	6.0	305-00155-000-007	M8-DIN376	6.0	4.9	305-00155-000-021
M12-JIS	8.5	6.5	305-00155-000-008	M10-DIN376	7.0	5.5	305-00155-000-022
M14/M15-JIS	10.5	8.0	305-00155-000-009	M12-DIN376	9.0	7.0	305-00155-000-023
UNC5/16-JIS	6.1	5.0	305-00155-000-040	M14-DIN376	11.0	9.0	305-00155-000-024



MT3 #2 Range Tapping Chuck & #2 Range Clamp Collets

MT3 Large Range Tapping Chuck (For Clamp Collets 7 ~ 25mm) **302-04293-901-002**

Clamp Collets				Clamp Collets			
Nominal Tap	Shank	Size of	Part Number	Nominal Tap	Shank	Size of	Part Number
Sizes:	Dia.:	Square:		Sizes:	Dia.:	Square:	
M7/M8-JIS	6.2	5.0	305-00155-000-030	UNC 1/2-JIS	9.0	7.0	305-00155-000-042
M9/M10-JIS	7.0	5.5	305-00155-000-031	UNC 5/8-JIS	12.0	9.0	305-00155-000-046
M11-JIS	8.0	6.0	305-00155-000-032	M8-DIN376	6.0	4.9	305-00155-000-036
M12-JIS	8.5	6.5	305-00155-000-033	M10-DIN376	7.0	5.5	305-00155-000-037
M14/M15-JIS	10.5	8.0	305-00155-000-034	M12-DIN376	9.0	7.0	305-00155-000-038
M16-JIS	12.5	10.0	305-00155-000-010	M14-DIN376	11.0	9.0	305-00155-000-039
M18-JIS	14.0	11.0	305-00155-000-011	M16-DIN376	12.0	9.0	305-00155-000-025
M20-JIS	15.0	12.0	305-00155-000-012	M18-DIN376	14.0	11.0	305-00155-000-026
M22 / UNC7/8 -JIS	17.0	13.0	305-00155-000-013	M20-DIN376	16.0	12.0	305-00155-000-027
M24/M25-JIS	19.0	15.0	305-00155-000-014	M22 / M24 -DIN376	18.0	14.5	305-00155-000-028



MT3 Annular Cutter Arbors w/ 19.05 (3/4") or 31.75 mm (1-1/4") Weldon Shank

(2 Set Screws, C- clip, Washer, O-ring, Water seal , and Spring are included)

Sizes:	Application	Part Number
ø19.05 mm (3/4") (L 186 mm), 50 mm depth	MD120/4	0299-0078-00000-003
ø19.05 mm (3/4") (L 212 mm), 50 mm depth	MD750/4	0299-0078-00000-009
ø19.05 mm (3/4") (L 237 mm), 75 mm depth	MDS750/4, MD120/4	0299-0078-00000-010
ø31.75 mm (1-1/4") (L 156 mm), 50 mm depth	MD120/4	0299-0078-00000-035
ø31.75 mm (1-1/4") (L 223 mm), 100 mm depth	MD120/4	0299-0078-00000-042



MT3 Quick-Release Annular Cutter Arbors w/19.05 (3/4") Weldon Shank*

(Spring & Water seal are included)

Sizes:	Application	Part Number
Single flat side with lock pin 12.3 mm	MD750/4, MD120/4	0299-0078-00000-001
Single flat side with lock pin 11.7 mm	MD750/4, MD120/4	0299-0078-00000-005
Single flat side with lock pin 12.3 mm	MDS750/4	0299-0078-00000-012
Single flat side with lock pin 11.7 mm	MDS750/4	0299-0078-00000-015
Two flat side with lock pin 12.3 mm	MDS750/4	0299-0078-00000-024
Two flat side with lock pin 11.7 mm	MDS750/4	0299-0078-00000-016



*60 mm cutter maximum capacity

Quick-Release Chuck Adaptors

Description	Application	Part Number
Single flat side (shank 17.4mm) Chuck adaptor for 1/2" chuck	SMD series	302-04240-901-001
Two flat side (shank 17.4mm) Chuck adaptor for 1/2" chuck		302-04240-901-002
Single flat side (shank 17.9mm) Chuck adaptor for 1/2" chuck		302-04240-903-003
Two flat side (shank 17.8mm) Chuck adaptor for 1/2" chuck		302-04240-903-004



Pilot Pins

Description:	Dimensions	Part Number
Pilot Pin for 12-17 mm TCT 35L cutters	TCT - 90L x Ø 6.34 mm	305-00016-000-009
Pilot Pin for 18-60 mm TCT 35L cutters	TCT - 90L x Ø 7.98 mm	305-00016-000-008
Pilot Pin for 12-17 mm TCT 50L cutters	TCT - 106L x Ø 6.34 mm	305-00016-000-010
Pilot Pin for 18-60 mm TCT 50L cutters	TCT - 108L x Ø 7.98 mm	305-00016-000-011
Pilot Pin for 12-100 mm HSS 30L cutters	HSS - 77L x Ø 6.34 mm	305-00016-000-002
Pilot Pin for 12-100 mm HSS 50L cutters	HSS - 103L x Ø 6.34 mm	305-00016-000-003



Chuck Adaptors (to allow mounting of a chuck for twist drilling)

Description:	Mount	Application	Part Number
Chuck Adaptor for 5/8" Chucks (5/8"-16 UNF)	M27-3.0	MD500/2	302-04020-901-014



Description:	Mount	Application	Part Number
Chuck Adaptor for 5/8" Chucks	MT3 / 5/8"-16	MD750/4, DS750/4, MD120/4	0202-0016-00000-001
Chuck Adaptor for B16 Taper Mount Chucks	MT3 / B16		302-04020-901-009



Drill Chucks & Chuck Keys

Description & Clamping Capacity	Mount	Application	Part Number
5/8" Chuck (w/ Key) (1 mm~16 mm)	5/8"-16	EVP180 , MD750/4 , MDS750/4 MD500/2 , MD120 (MT3 Machines)	305-00014-000-002
1/2" Chuck (w/ Key) (1 mm~13 mm)	1/2"-20	EV21 , MD500/2 , SMD351H , SMD351L , SMD352 , SMD502 , ST50	305-00014-000-001



Magnetic Chip Collector

(Push in the plunger to activate magnetic force to collect chips,
Pull back the plunger to release the chips.)

Dimensions	Part Number
400 mm x 25 mm	305-00173-000-001



CS320 METAL CUTTING CIRCULAR SAW

PATENTED

Quickly cut metals such as steel, stainless, aluminum and others using 320 mm TCT dry cut blades for accurate, burr-free cuts. Extra deep 121 mm depth of cut and optional guide rail make it especially suited to cutting thick, corrugated sandwich panels.



OPTIONAL ACCESSORIES:

The guide rail allows perfectly straight cuts and the cut-to-fit rubber strip shows the operator exactly where the cutting line will be.



Guide Rail 1400 mm
Guide Rail 800 mm

Features

1. Unique, patented dust chamber cover opens and snaps closed in seconds. Highly effective dust and debris collection.
2. Large cutting capacity provided by the 320 mm metal cutting blade. A full 121 mm depth of cut when mounted on a guide rail.
3. Guide clearance adjustor.
4. Kicker Lever for opening the lower blade guard on thick, soft-cored sandwich panels.
5. LED Load Indicator enables maximum efficiency.

Standard/Optional Accessories See p. 23

Model	CS320
Power Input	1800 W (220-240 V), 1700 W (110-120 V)
Voltage, Frequency	220-240 V~ 50-60 Hz, or 110-120 V~ 50-60 Hz
No Load min ⁻¹ / Rated Load min ⁻¹	1700 / 1020
Rated Blade Diameter	320 mm
Arbor Hole Diameter	25.4 mm (1")
Max Cutting Depth	128 mm (121 mm on Guide Rail)
Soft Start & Overload Protection	With
Dimensions (LxWxH)	500 x 342 x 355 mm
Net Weight	8.4 kg (18.5 lb)

Characteristics / Certification

Circular Saw Accessories

CS320 Metal Cutting Circular Saw

Optional Accessories	Part Number
a Guide Rail 1400 mm	0299-0065-00164-001
a Guide Rail 800 mm	0299-0065-00164-002
b Guide Rail Connector	0299-0106-00000-001
c Lever Clamp	305-00179-000-001
d TCT Saw Blades (Excellent for sandwich panel)	305-00036-000-054



a Guide Rail



b Guide Rail Connector



c Lever Clamp



d TCT Saw Blades (Excellent for sandwich panel)

TCT Saw Blades



TCT Saw Blades for Steel:										
Application	Dia. (mm)	Kerf. (mm)	Bore (mm)	Teeth	Plate (mm)	Hardness HRA	Carbide (mm)		Hook Angle	Grind
							Thick	Length		
CS320	320	2.2	25.4	80	1.8	90.8	1.9	6.2	0°	TCG

Note: Tooth Grind Patterns

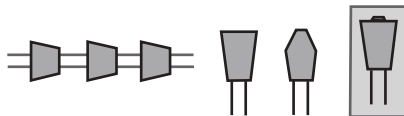

TCG (Triple Chip Grind)

Ideal for metal cutting blades. Gives long sharp life in hard materials. The pointed tooth cuts narrow kerf, then the flat-top raker tooth widens the kerf and clears out chips.

CS320 Work Materials



Sandwich Panels up to 120 mm thick



Box Section Steel



Steel Tubing



Aluminum Extrusions



Diamond Plate



Metal gratings





DRC355 DRY-CUT METAL SAW

Quickly cut metals such as steel, stainless, aluminum and others using 355mm (14") TCT dry cut blades for accurate, burr-free cuts. Up to 3 times faster than conventional abrasive wheel cut-off saws. Can also perform left and right miter cuts.



Features

1. High-stability cast alloy base.
2. Fence with scale swivels 45° in both directions with quick detents for the popular miter angles: 0°-15°-30°-45° left and right.
3. The locking holes may be used, if desired, for extra secure fence locking.
4. Two-piece Lower Blade Guard.
5. Tool-Free Fence Lock.
6. Quick-Lock Vise with Speed Crank.
7. Chip Tray.

Model	DRC355		
Power Input	2200 W		
Voltage, Frequency	220-240 V~ 50-60 Hz or 110-120 V~ 50-60 Hz		
No Load min ⁻¹	1300		
Rated Load min ⁻¹	780		
Max Blade Diameter	355 mm (14")		
Max. Cutting Capacities	90°	Round Pipe	132 mm
		Square Stock	120 mm (W) x 120 mm(H)
		Rectangular Stock	180 mm(W) x 100 mm(H)
	Right Hand Miter		
	45°	Round Pipe	105 mm
		Square Stock	90 mm(W) x 90 mm(H)
		Rectangular Stock	90 mm(W) x 120 mm(H)
	Left Hand Miter		
	25°	80 mm(W) x 120 mm(H)	
	30°	90 mm(W) x 120 mm(H)	C-clamp required
	35°	80 mm(W) x 120 mm(H)	C-clamp required
	45°	70 mm(W) x 120 mm(H)	C-clamp required
Arbor	25.4 mm (1")		
Soft Start	With		
Dimensions (LxWxH)	680 x 360 x 580 mm		
Net Weight	23.5 kg (51.7 lb)		
Characteristics & Certification	  Only 220V  Only 220V  US		



Tool-free angle adjustment with detents. The locking holes may also be used, if desired, for extra-secure fence locking.



Quick-Lock Vise with Speed Crank



Chip tray

Circular Saw Accessories

Standard Accessories	Part Number	Optional Accessories	Part Number
M4 Hex Key	305-00010-901-002	V-jig Block	201-0030-00902-001
M6 Hex Key	305-00010-901-003	Safety Goggles	305-00056-000-001
M8Hex Key	305-00010-901-005	Lever Clamp	305-00179-000-001
		TCT Saw Blade	305-00036-000-001



V-jig Block



Lever Clamp

TCT Saw Blades for Steel

Part Number 305-00036-000-001

Dia. (mm)	Kerf. (mm)	Bore (mm)	Teeth	Plate (mm)	Hardness HRA	Carbide (mm)		Hook Angle	Grind
						Thick	Length		
355	2.4	25.4	80	2.0	90.8	1.9	6.2	0°	TCG



Note: Tooth Grind Patterns

TCG (Triple Chip Grind)

Ideal for metal cutting blades. Gives long sharp life in hard materials. The pointed tooth cuts narrow kerf, then the flat-top raker tooth widens the kerf and clears out chips.

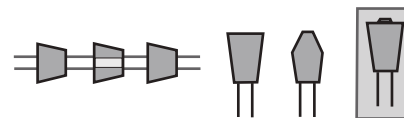

DRC355 Work Materials



Steel Tubing

Box Section Steel



Aluminum Extrusions

Diamond Plate

HC127 HOLE CUTTING DRILL

A convenient tool for quickly drilling perfectly centered and perpendicular holes up to 127 mm diameter in pipes from 1-1/4" to 8-1/4". Excellent for installing mechanical tee fittings, pipe saddles, etc. Uses TCT hole saws.



Model	HC127
Power Input	1100 W
Voltage, Frequency	220-240 V~ 50-60 Hz or 110-120 V~ 50-60 Hz
No Load min ⁻¹	130
Max. Cutting Capacity (Hole Cutter)	127 mm
Pipe Mounting Capacity	32 mm - 203 mm (600 mm w/ optional Long Chain Set)
Drill Chuck Capacity	16 mm shank
Overload Protection	With
Net Weight	14.5 kg (31.9 lb) Not including Crank Handle
Characteristics / Certification	   

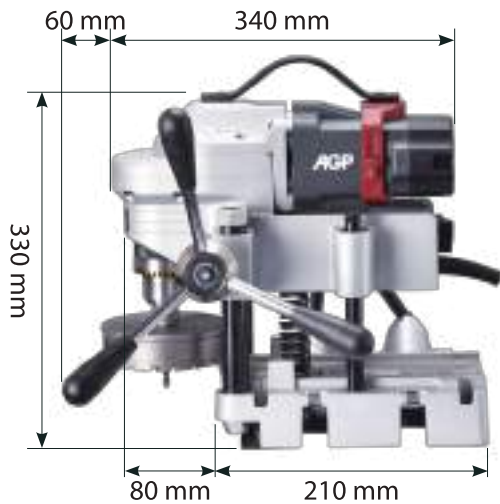

Features

1. Good balance for carrying.
2. The quick adjustable tool-free lever can mount on either side.
3. Chain vise clamping system quickly mounts machine onto 1-1/4" to 8-1/4" diameter pipe. (32 mm-203 mm)
4. Built-in bubble levels for multiple hole alignment.

Standard Accessories	
16 mm (5/8") Chuck & Chuck Key	305-00014-000-002
Crank Handle Set	299-0068-00004-001
Optional Accessories	
Long Chain Set (for pipes up to 600 mm diameter)	305-00035-000-002

T14 TAPPER

A convenient tool for quickly tapping a series of through holes or blind holes up to M16 (5/8"). The auto-reverse gearbox mechanism makes tapping a super fast operation.



Features

1. 2-Jaw Universal Tapping Chuck is self-centering and grips any size tap from M6 up to M16.
2. Unique, purpose-built gearbox makes tapping fast, efficient, and uniquely controllable. Press down for low-g geared clockwise rotation. Pull back for high-g geared counterclockwise rotation. Neutral in the center.
3. Ergonomic handle makes it easy to hold the tool straight.
4. Depth Stop for blind hole tapping.
5. Long Side Handle for excellent control.
6. Safety Clutch integrated with the spindle.

Model	T14		Standard Accessories	
Power Input	450 W		Side Handle	203-0001-00000-001
Voltage, Frequency	220-240 V~ 50-60 Hz, or 110-120 V~ 50-60 Hz		M4 Hex Key	305-00010-901-002
No Speed min ⁻¹	Forward	280	Depth Stop	0202-0118-00000-001
	Reverse	680		
Tapping Capacity	Steel	14 mm (9/16")		
	Aluminum	16 mm (5/8")		
Dimensions (LxWxH)	400 x 80 x 200 mm			
Net Weight	2.7 kg (5.9 lb) (Not including side handle 0.45 kg (1lb))			
Characteristics / Certification				

AGP[®]



www.agp-powertools.com
2025.01