

# AGP<sup>®</sup>

## Drill Motor

DM52D / DM52P



DM52D



Water Feed Adaptor Head



DM52P

# Instruction Manual

CE CB 



## TECHNICAL DATA

Model	DM52D	DM52P
Power Input	1800 W	
Voltage	110-120 V~50-60 Hz, or 220-240 V~50-60 Hz (see nameplate)	
No Load /Full Load min <sup>-1</sup>	Speed 1	1800 / 1080
	Speed 2	3600 / 2160
Percussion Frequency (optional)	Speed 1	29,000 bpm
	Speed 2	56,000 bpm
Arbor Thread	1-1/4-7 UNC male x 1/2" BSP female or M18-2.5 or 1/2" BSP (Specify when ordering)	
Capacity-Wet	82 mm	
Capacity-Dry	182 mm ( 7-1/4")	
Dimensions (LxWxH)	505 x 105 x 210 mm	450 x 105 x 280 mm
Neck Diameter	60 mm	60 mm
Net Weight	5.0 kg	4.9 kg

## DM52D

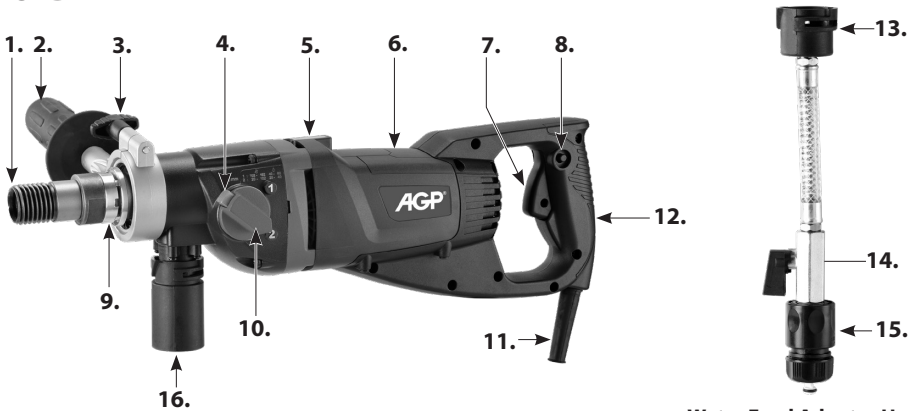

**Water Feed Adaptor Head (optional)**

1. Spindle
2. Side Handle
3. Lock Screw
4. Release Button
5. Tubular Spirit Level
6. Motor
7. Trigger Switch
8. Lock Button
9. Percussion Selector
10. Gear Selector
11. Power Supply Cable
12. Main Handle
13. Port Connector
14. Water Feed Valve
15. Hose Coupling
16. Vacuum Adaptor Head

## DM52P

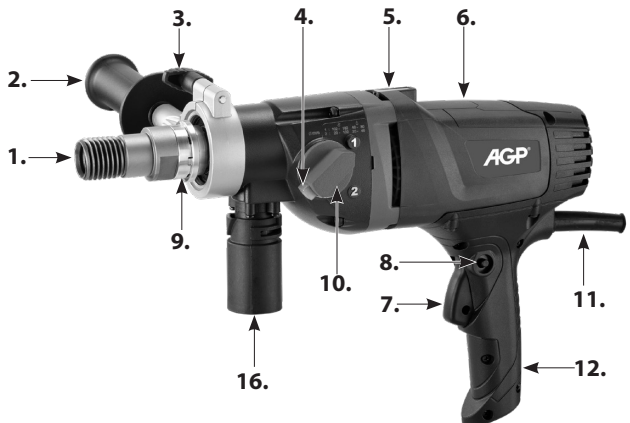

## GENERAL SAFETY INSTRUCTIONS



**WARNING** Read all safety warnings and all instructions. Failure to follow the warnings and instructions may result in electric shock, fire and/or serious injury.

Save all warnings and instructions for future reference.

The term "power tool" in the warnings refers to your mains-operated (corded) power tool.

### 1) Work area safety

- a. **Keep work area clean and well lit.** Cluttered or dark areas invite accidents.
- b. **Do not operate power tools in explosive atmospheres, such as in the presence of flammable liquids, gases or dust.** Power tools create sparks which may ignite the dust or fumes.
- c. **Keep children and bystanders away while operating a power tool.** Distractions can cause you to lose control.
- d. **Never leave the electric power tool unattended.** Only leave the machine when the tool in use has come to a complete standstill.

### 2) Electrical safety

- a. **Power tool plugs must match the outlet. Never modify the plug in any way. Do not use any adapter plugs with earthed (grounded) power tools.** Unmodified plugs and matching outlets will reduce risk of electric shock.
- b. **Avoid body contact with earthed or grounded surfaces, such as pipes, radiators, ranges and refrigerators.** There is an increased risk of electric shock if your body is earthed or grounded.
- c. **Do not expose power tools to rain or wet conditions.** Water entering a power tool will increase the risk of electric shock.
- d. **Do not abuse the cord. Never use the cord for carrying, pulling or unplugging the power tool. Keep cord away from heat, oil, sharp edges or moving parts.** Damaged or entangled cords increase the risk of electric shock.
- e. **When operating a power tool outdoors, use an extension cord suitable for outdoor use.** Use of a cord suitable for outdoor use reduces the risk of electric shock.
- f. **If operating a power tool in a damp location is unavoidable, use a residual current device (RCD) protected supply.** Use of an RCD reduces the risk of electric shock.

### 3) Personal safety

- a. **Stay alert, watch what you are doing and use common sense when operating a power tool. Do not use a power tool while you are tired or under the influence of drugs, alcohol or medication.** A moment of inattention while operating power tools may result in serious personal injury.
- b. **Use personal protective equipment. Always wear eye protection.** Protective equipment such as dust mask, non-skid safety shoes, hard hat, or hearing protection used for appropriate conditions will reduce personal injuries.
- c. **Prevent unintentional starting. Ensure the switch is in the off-position before connecting to power source and/or battery pack, picking up or carrying the tool.** Carrying power tools with your

finger on the switch or energising power tools that have the switch on invites accidents.

- d. **Remove any adjusting key or wrench before turning the power tool on.** A wrench or a key left attached to a rotating part of the power tool may result in personal injury.
- e. **Do not overreach. Keep proper footing and balance at all times.** This enables better control of the power tool in unexpected situations.
- f. **Dress properly. Do not wear loose clothing or jewellery. Keep your hair, clothing and gloves away from moving parts.** Loose clothes, jewellery or long hair can be caught in moving parts.
- g. **If devices are provided for the connection of dust extraction and collection facilities, ensure these are connected and properly used.** Use of dust collection can reduce dust-related hazards.
- h. **Do not let familiarity gained from frequent use of tools allow you to become complacent and ignore tool safety principles.** A careless action can cause severe injury within a fraction of a second.

#### 4) Power tool use and care

- a. **Do not force the power tool. Use the correct power tool for your application.** The correct power tool will do the job better and safer at the rate for which it was designed.
- b. **Do not use the power tool if the switch does not turn it on and off.** Any power tool that cannot be controlled with the switch is dangerous and must be repaired.
- c. **Disconnect the plug from the power source and/or the battery pack from the power tool before making any adjustments, changing accessories, or storing power tools.** Such preventive safety measures reduce the risk of starting the power tool accidentally.
- d. **Store idle power tools out of the reach of children and do not allow persons unfamiliar with the power tool or these instructions to operate the power tool.** Power tools are dangerous in the hands of untrained users.
- e. **Maintain power tools. Check for misalignment or binding of moving parts, breakage of parts and any other condition that may affect the power tool's operation. If damaged, have the power tool repaired before use.** Many accidents are caused by poorly maintained power tools.
- f. **Keep cutting tools sharp and clean.** Properly maintained cutting tools with sharp cutting edges are less likely to bind and are easier to control.
- g. **Use the power tool, accessories and tool bits etc. in accordance with these instructions, taking into account the working conditions and the work to be performed.** Use of the power tool for operations different from those intended could result in a hazardous situation.
- h. **Keep handles dry, clean and free of oil and grease.** Slippery handles do not allow for safe handling and control of the tool in unexpected situations.

#### 5) Service

**Have your power tool serviced by a qualified repair person using only identical replacement parts.**

This will ensure that the safety of the power tool is maintained.

## Symbols used in this manual

V.....volts

A.....amperes

Hz.....hertz

W.....watt

~.....alternating current

$n_0$ .....no load speed

$\text{min}^{-1}$ .....revolutions or reciprocation  
per minute



.....warning of general danger



.....class II tool



.....read these instructions



.....always wear eye protection



.....always wear a dust mask.



.....always wear hearing protection



.....wear safety-approved hard hat



do not dispose of electric tools,  
accessories and packaging together  
with household waste material

## DRILL SAFETY WARNINGS

1. **Wear ear protectors when impact drilling.** Exposure to noise can cause hearing loss.
2. **Use auxiliary handle(s), if supplied with the tool.** Loss of control can cause personal injury.
3. **Hold power tool by insulated gripping surfaces, when performing an operation where the cutting accessory may contact hidden wiring or its own cord.** Cutting accessory contacting a "live" wire may make exposed metal parts of the power tool "live" and could give the operator an electric shock.
4. **The locking screw for the ground/earth cable may never be loosened, otherwise there is acute danger to life!**
5. **Check the ground (earth) connection of the electrical plug.**
6. **Take care not to damage gas, water, power and other conduits in the area of the drilling operation.** Drain or shut off these conduits as required.
7. **Block off the working area and place warning signs on both sides of the wall when drilling through from one side to the other.**
8. **Take appropriate precautions to ensure that, in the event of a drilling core dropping out, no personal injury or material damage will result.**
9. **When drilling hollow components, check the flow route of the cooling water in order to prevent damage.**
10. **Always hold the machine tightly.** Diamond core drilling bits can become stuck at any time during core drilling, there is a danger of the machine jumping out of control.
11. **WARNING: Pull the plug out of the socket before making device settings or changing accessories.** Many accidents are caused by accidental starting of power tools.

## SPECIAL SAFETY WARNINGS FOR WET DRILLING (Water feed models only)

1. **Never use the machine without the PRCD fault-current safety switch supplied.**

2. **Always check the PRCD fault-current safety switch for correct functioning before starting a drilling operation.**
3. **Ensure that no water is allowed to get into the motor unit during operation.**
4. **If you detect a leak in any part of the water supply system, shut the machine down immediately and repair the fault. Water pressure should not exceed 70 psi (4 bar).**

## INTRODUCTION

The machine is equipped with a tubular spirit level to aid in aligning when drilling horizontally. By positioning the machine so that the bubble is in the center of the window one can drill a straight hole.

This machine is for the intended purpose of diamond core drilling of concrete, masonry, stone and similar materials. It may also be mounted on a rig (drilling stand). The rig is not included.

All other uses which are not for the intended purpose are prohibited.

Some models are equipped with a water feed system. These models are equipped with a PRCD interrupter (GFCI) which must be used at all times.

It is equipped with a two speed gearbox.

Some models are convertible between water feed and dust aspiration.

All models are equipped with a mechanical safety clutch.

All models have electronics for soft start, overload protection, thermal protection and a unique overload warning system.

## ELECTRICAL CONNECTION

The network voltage must conform to the voltage indicated on the tool name plate.

Under no circumstances should the tool be used when the power supply cable is damaged. A damaged cable must be replaced immediately by an authorized Customer Service Center. Do not try to repair the damaged cable yourself. The use of damaged power cables can lead to an electric shock.

### **WARNING: (Machines for wet drilling only)**

**This machine is equipped with a Portable Residual Current Device (PRCD) also known as a Ground Fault Circuit Interrupter (GFCI). Always use this device whenever using the machine to reduce the risk of shock hazards. Always position the device PRCD as close as possible to the power source. Test and reset the PRCD device before each use. Press the "Test" button to test. Press the "Reset" button to energize the circuit to the machine.**

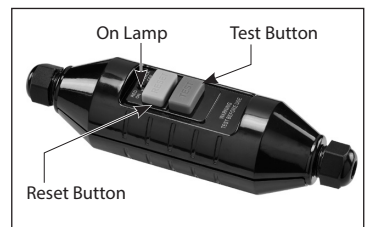

**WARNING: Always connect the plug into the wall socket with a drip loop. If the cable leads downward directly into the wall socket, any water on the cable could run into the socket, causing a hazard.**

## ASSEMBLY

Mount the handle clamp of the side handle onto the gearbox neck. Position the side handle perpendicular to the main handle. Use the lock screw to tighten the clamp.

## LIST OF CONTENTS

- Diamond core drilling machine.
- Side handle assembly
- Water feed adaptor (optional)
- Vacuum adaptor (optional)

## OPERATING INSTRUCTIONS

### Mounting the core bit

**CAUTION: Ensure that the threads of the spindle and the core bit match. Attempting to mount mismatched threads will result in damage to both threads.**

Ensure both the core bit and the machine spindle are clean. Any debris could cause excessive run-out of the mounted core bit. Excessive run-out can cause premature failure of the core bit and/or a safety hazard. Tighten the bit to the spindle using two wrenches. Only use correct sized wrenches to avoid damage to the spindle or bit.

### Choosing the correct core bit for the job:

Ensure that the bit you are using is suitable for the material you are drilling. There are two main types of diamond core bit:

**Wet/dry type-electroplated (surface set) diamond core bits and wet type-sintered (impregnated) diamond core bits.**

### Dry drilling models should only use Dry type bits:

Electroplated bits, also known as wet/dry type, are only suitable for less hard materials. The diamonds are sharp and coarse and are only set on the surface. They have a much shorter service life than sintered bits and cannot be dressed (resharpened). Once they become dull, they must be replaced. They tend to work well with softer, abrasive materials like brick. Only dry type bits are suitable for use with soft impact function.

### Wet drilling models are recommended to use Wet type bits:

Sintered bits, also known as wet type, are much longer lasting but require operator knowledge for best results. Water is absolutely always required with sintered bits. The bit is impregnated with many layers of diamond in its metal matrix. As the matrix (bond) wears, new diamonds are exposed. If the bit becomes glazed, it can be resharpended by dressing with an appropriate alumina oxide or silicon carbide dressing stick. There are many

variables with sintered diamond core bits, such as diamond grade and type, diamond grit size, bond type, bond hardness, and bit wall thickness. Consult with your diamond core bit supplier for the best bit for your application. Work materials vary widely in hardness.

**CAUTION: Wet type bits must never be used with percussion function**

## **SPECIAL INSTRUCTIONS FOR WET DRILLING (Wet drilling models only)**

Water is a basic requirement for wet diamond core drilling. The water serves as a coolant to avoid the working surface at the tip of the bit from overheating. When the diamond bit becomes overheated, both the bond matrix and even the diamonds break down. The most frequent cause of diamond core bit damage is caused by drilling without enough coolant water.

Water should always be used to cool and lubricate the bit and to flush out abrasive particles formed while drilling.

To connect the water supply. Attach the quick-release water coupling to a water hose.

**WARNING: Never allow water to enter the motor. It could lead to an electric shock.**

**WARNING: Check all connections of the water feed system to ensure there are no leaks. Inspect hoses and other critical parts which could deteriorate.**

**WARNING: The maximum water pressure should not exceed 70 psi (4 bar).**

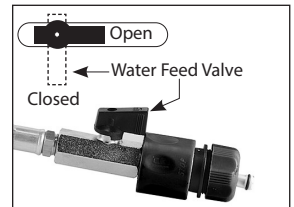

Use a water collector with a wet vacuum to collect cooling water if nearby objects could be damaged by water.

**WARNING: Never allow water to enter the motor. A perfectly functioning water collector set up must be used for any drilling performed at an upward angle.**

## **SPECIAL INSTRUCTIONS FOR DRY DRILLING: (Dry drilling models only)**

Dry drilling is a different process from wet drilling. With wet drilling, it is more of a grinding process and you need a lot of downforce to grind away the material. But with dry drilling, it is more of a cutting process and you must use a much lighter touch.

When dry drilling, you must not push too hard. Allow the tool to work at its own pace.

Dry drilling is normally done in softer materials. Note that in very hard materials it may not be possible to drill dry.

## **SPECIAL INSTRUCTIONS FOR WET/DRY CONVERTIBLE MODELS:**

One may mount either the dust aspiration or the water feed coupling adapters as needed.

Use the dust aspiration coupling for through-the-spindle dust aspiration with a vacuum cleaner for dry drilling.



Use the water feed coupling for wet drilling.

At the bottom of the gearbox just behind the spindle, there is a large port with a bayonet mount. To mount the desired coupling, simply align the tangs, push in and turn clockwise to lock. Removal is the reverse of assembly

## SELECTING SPEEDS

There are 2 speed ranges to suit the bit size and work piece hardness. Choose the slowest speed for large diameter bits and hard materials. If when cutting the bit stalls repeatedly, then you must change to a lower gear. If you are already in the lowest gear and the bit stalls repeatedly, then you are using the machine over its maximum capacity.

**CAUTION: Never attempt to change gears on a running machine! Only adjust when the machine is at rest.**

Select the desired gear range by pressing the release button and then turning the gear selector either clockwise or counterclockwise into the desired gear. It will usually be necessary to turn the spindle by hand a little to get it to shift all the way.

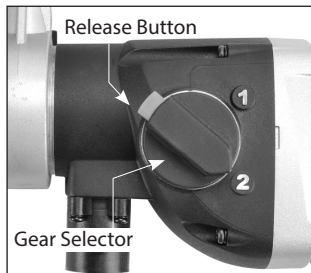

## PERCUSSION SELECTOR

On models which are equipped with soft percussion for dry drilling, the percussion function can be turned on and off.

The selector is a knurled collar at the front of the gearbox. To select, first unplug the machine, then push down on the collar against the spring tension to disengage the teeth of the selector from the slots. It is sometimes helpful to pull out on the spindle to give the collar enough room to push in. Observe the symbol laser engraved on the selector and turn to either the "Hammer" symbol for soft percussion or the "No Hammer" symbol to turn the percussion OFF.

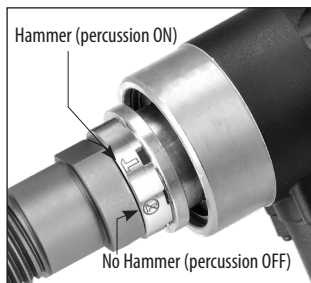

## THE SWITCH

The machine has a lockable trigger switch. Squeeze the trigger to start the machine. To lock the switch on, press the lock button while holding the trigger switch on. To release, squeeze the trigger and release.

**WARNING: Never lock the switch on when drilling hand-held. Only lock the switch on when mounted to a rig.**

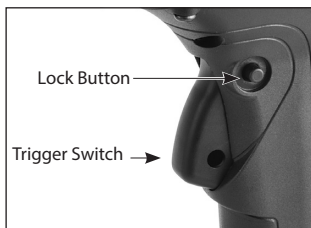

## OVERLOAD PROTECTION AND OVERHEAT PROTECTION

### Overload:

If the excessive load is sustained too long, the motor will shut down completely. In this case, the motor must be restarted by turning OFF and then back ON the switch. When this happens, the motor will very likely be near overheating, so it is also a good idea to run the motor at no load for a few minutes to cool it before continuing.

### Overheat Thermal Protection:

If the temperature of the motor gets too high, the thermal protection will shut the motor down. When this happens, do not immediately put a load on the motor after restarting. Always run the machine at no load for a few minutes to return to a normal operating temperature before continuing.

**CAUTION: The motor will be damaged if it is repeatedly overloaded or overheated. Always cool the motor by running at no load for a few minutes whenever it stops from either overheat or overload.**

## SAFETY CLUTCH

This machine is equipped with a mechanical clutch to protect the operator and machine from excessive torque forces. When the preset maximum torque level is reached, the clutch will slip. After the clutch slips many times, it will become worn and slip at lower and lower torque levels. When this happens, it must be serviced by an authorized service provider. The recommended torque of the clutch nut is 21 Nm.

## DIAMOND CORE DRILLING

**WARNING: When coring through a floor, the core will fall down. Take precautions to avoid injury or damage below.**

**NOTE: When drilling with a new bit for the first time, use less than normal feed pressure for a time until it breaks-in.**

1. Squeeze the trigger switch to turn the machine on. (For wet drilling and convertible models, press the "Reset" button on the PRCD interrupter device to energize the circuit to the machine before starting.)

**WARNING: Hold the machine tightly with both hands to counteract the torque reaction force when the bit begins to turn.**

2. Very gently begin the cut. If holding by hand, start the cut by approaching at an angle of about 30 degrees to the cutting surface. (A large piece of wood with a large V notch cut in it will help prevent the bit from wandering at the beginning.) Once about a third of the arc is cut, straighten the bit to the correct perpendicular angle while keeping enough feed pressure on the bit to prevent it from wandering. (If using a rig, use very light feed pressure to prevent the bit from wandering until the bit is fully penetrated into the cut.)

**For wet drilling models:**

1. Make adjustments to the water feed as needed. The water leaving the cut should be a solid colored slurry with about the consistency of milk. If the exiting water is clear, then you may reduce the water flow. If the exiting water is thick and muddy, then increase the water. It's very important that the water has enough pressure to flush cutting debris out of the cut.
2. Once in the cut, use steady feed pressure .
3. When the cut is almost finished and the bit is about to break through, the bit will be very liable to get stuck. Take extra care gripping the machine tightly and reduce feed pressure at this point.

**WARNING: Whenever drilling by hand, always hold the drill in a position so that you can resist the considerable twisting forces created when the bit grabs. Never operate without the side handle tightly in place.**

**WARNING: When the bit grabs, the machine will always twist in the counterclockwise direction. If you are drilling into the floor, make sure that the side handle is in front of your left leg, never between your legs.**

**WARNING: Always keep your face away from the machine.**

Arrange the power supply cable with minimal slack and oriented in such a way that if the machine gets out of control and spins, it will immediately unplug its own cable.

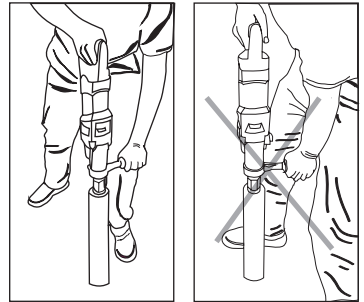

Right

Wrong

## ADDITIONAL SPECIAL INSTRUCTIONS FOR WET DRILLING

The diamond impregnated segments in a wet type (sintered) diamond core bit operate on a principle of controlled erosion. The bond matrix holding the diamonds is continually worn away by abrasion with the work piece, exposing the harder diamonds to stand proud from the bond matrix. A bit with good diamond exposure is a sharp bit.

This erosion process causes heat and particles, which require water to cool and rinse free. Without adequate water, the bit would overheat and be destroyed.

With too much water and not enough feed pressure, there would not be adequate erosion of the bond matrix (the diamonds not exposed) and the bit becomes dull (diamond segments polish smooth). This is called glazing and luckily the bit can be de-glazed (sharpened). If the bit seems to refuse to cut anymore, you know that it is glazed.

### See below: "SHARPENING A GLAZED BIT "

Never use a sharp motion or the bit will be damaged. Conversely, don't feed too gently or the diamond segments will become glazed. Keep the bit steadily working, but don't be abusive or give the bit shock impacts into the work surface.

If holding by hand, take great care to keep the bit aligned to the hole. If the bit is crooked, it will easily bind.

If the cut is very deep, the core plug may be obstructing the flow of cooling water. In this case, stop drilling, and chisel out the core plug before continuing.

**CAUTION: If the bit gets stuck, do not try to rock it loose by turning the switch on and off. That is hazardous and could damage the motor. Rather, unplug the machine and use a wrench on the bit**

### **mounting to work it loose.**

If embedded steel such as rebar is encountered take special care. When the steel is encountered, the water will generally go clear and vibration will begin. Change to a lower gear if available. Reduce the feed pressure by about 1/3 and let the bit go at its own pace, if there is too much vibration the bit will be destroyed.

Once the steel is passed, continue normally. A properly sharp bit with good diamond exposure should be able to cut through rebar if handled well.

When the cut is finished keep the motor running until the bit is removed from the cut to avoid it getting stuck.

**CAUTION: Drilling operations are very stressful to the motor and at the end of the cut, the motor temperature will be very hot, always run the motor at no load for a few minutes until the temperature returns to a normal range before shutting off.**

### **For wet drilling machines:**

Turn the water feed down to a very small amount of flow (not off), just enough to keep the water seals from overheating when you perform this step.

Then turn off the switch and allow the coasting bit to stop before setting it down.

### **RESHARPENING A GLAZED BIT (Wet bits only)**

If the bit becomes glazed, the ideal way to sharpen and true it up is by dressing with an appropriate alumina oxide or silicon carbide dressing stone. Simply drill into the stick as many times as necessary to restore its cutting performance.

If it is only slightly dull, while cutting, you may first reduce the water flow by about half until the water exiting the kerf is really muddy.

Another method is to stop and add about 6mm (1/4") of coarse silica sand in the kerf and drill for a few minutes, then turn up the water to rinse the sand free. Repeat as needed.

Another method is to drill into a cinder block. Repeat as needed.

If that still does not work the only choice is to use a dressing stone.

### **VIBRATION TROUBLESHOOTING**

If vibration occurs and it is not caused by embedded steel, stop drilling to find the cause and remedy.

**CAUTION: Do not operate with vibration or there will be serious hazard and the diamond core bit will surely be destroyed.**

### **Vibration is usually caused by:**

1. A bit with too much runout  
**SOLUTION:** Replace bit.
2. A bit with diamond segments broken off  
**SOLUTION:** Repair or replace bit.

## KEEP TOOL CLEAN

Wipe down the machine at the end of each work day with a damp cloth.

NEVER use solvents to clean plastic parts. They could possibly dissolve or otherwise damage the material. Periodically blow low-pressure compressed air through the ventilation slots with the motor running to keep the motor clean so that motor can be cooled normally.

Wear safety glasses while using compressed air.

**CAUTION: When drilling in a position with the motor near to the floor, take measures to prevent dust, debris and slurry from being sucked into the motor's cooling slots**

## MAINTENANCE

Every 50 hours of operation blow compressed air through the motor while running at no load to clean out accumulated dust. (If operating in especially dusty conditions, perform this operation more often.)

To keep your diamond coring machine in top condition, periodic maintenance must be performed. In addition always check for a damaged power supply cable, check for loose fasteners and always keep alert for unusual noises and vibration when operating.

**WARNING: Never operate a damaged machine. Always tag a damaged machine and take it out of service until repairs can be made.**

Maintenance which should be performed by an authorized service center, include the following:

- Replace water seals as needed.
- Replace the carbon brushes as needed
- Change the gearbox grease about every 100 hours of operation
- Replace the clutch discs and spring as needed.

Each year perform a full mechanical inspection, cleaning and re-lubrication.

## THE CARBON BRUSHES

The carbon brushes are a normal wearing part and must be replaced when they reach their wear limit. This machine is equipped with auto-stop carbon brushes. If the machine comes to a stop unexpectedly, the brushes should be checked. The auto-stop brush design protects the motor by stopping the machine before the carbon brushes are completely worn out.

**Caution: Always replace the brushes as a pair.**

### **To replace:**

1. Remove the 12 screws (pistol handle models) or 14 screws (D handle models) to open up the handle halves. Carefully move the parts to one side, taking care not to strain the wiring.
2. Using pliers rotate the brush spring out of the way and slide the old carbon brush out of the brush holder.
3. Unscrew the screw to remove the brush lead. The old carbon brush may now be lifted away.
4. Install a new brush. Installation is the reverse of removal.
5. Replacement is the reverse of removal. Take care not to pinch any wires when reassembling.

**If the replacement of the power supply cord is necessary, this has to be done by the manufacturer or their agent in order to avoid a safety hazard.**

**WARNING: All repairs must be entrusted to an authorized service center.** Incorrectly performed repairs could lead to injury or death.

Do not throw electric power tools into the household waste!

In accordance with the European Directive 2002/96/EG on Waste Electrical and Electronic Equipment and transposition into national law, used electric power tools must be collected separately and recycled in an environmentally friendly manner.

# WIRING

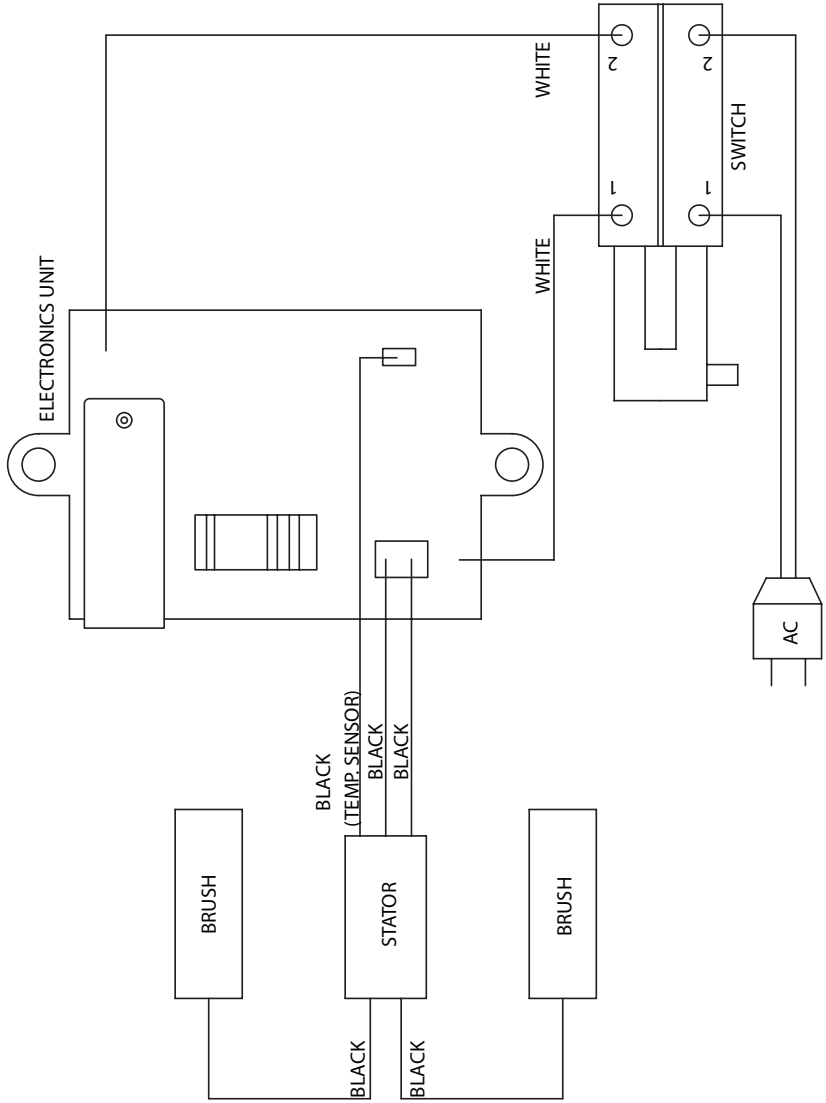

# DM52D Exploded View

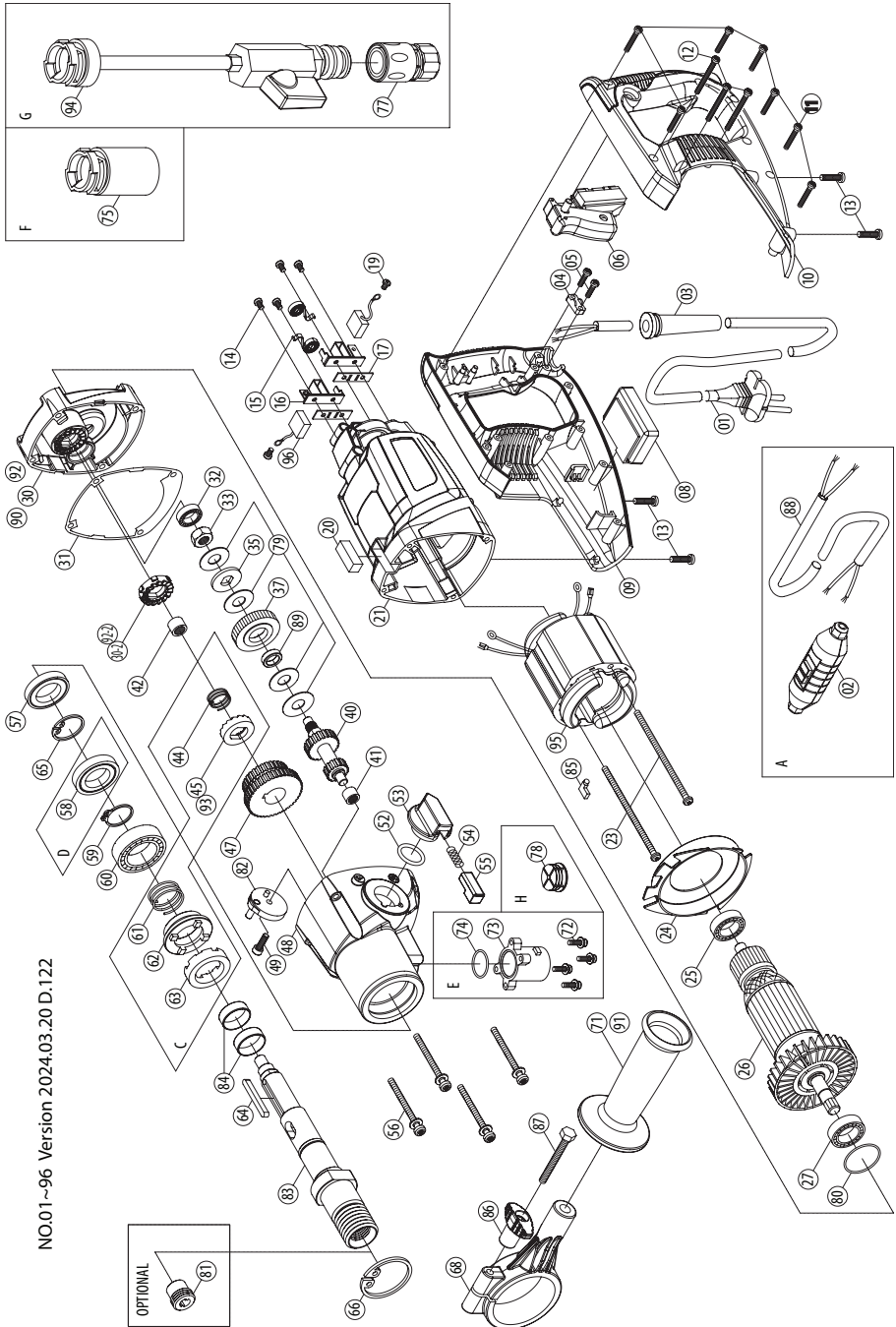

NO.01--96 Version 2024.03.20 D.1.122

OPTIONAL  
81



## DM52D Parts List

NO.	Parts Name	QTY	NO.	Parts Name	QTY
1.)	POWER SUPPLY CABLE (UK-1.5x3Cx3M-H07RNF)	1	55	RELEASE PIN	1
1.)	POWER SUPPLY CABLE (VDE-1.0x2Cx3M-H07RNF)	1	56	TORX PANHEAD TAPPING SCREW (M5x60)	4
1	POWER SUPPLY CABLE (VDE-1.0x2Cx1.4M-H07RNF)	1	57	OIL SEAL (Ø27xØ42x7)	1
2	PRCD INTERRUPTER PROTECTION (110V/220V)	1	58	OIL SEAL (Ø27xØ45x8)	1
3	CORD ARMOR	1	59	INTERNAL CIRCLIP (I528)	1
4	CABLE CLIP	1	60	BALL BEARING (60/28)	1
5	PANHEAD TAPPING SCREW (M4x14)	2	61	SPRING (Ø1.2xØ28xØ30.4x7Tx40L)	1
6	SWITCH (110V&220V)	1	62	IMPACT SELECTOR COLLAR	1
8	ELECTRONICS UNIT (110V/220V)/(110V/220V-AVR)	1	63	ENGAGEMENT COLLAR	1
9	D-HANDLE HALF-RIGHT	1	64	PARALLEL KEY (5x5x45)	1
10	D-HANDLE HALF-LEFT	1	65	INTERNAL CIRCLIP (R-42)	1
11	PANHEAD TAPPING SCREW (M4x25)	7	66	INTERNAL CIRCLIP (R-52)	1
12	PANHEAD TAPPING SCREW (M4x35)	3	68	HANDLE CLAMP	1
13	TORX PANHEAD TAPPING SCREW (M5x20)	4	71	FRONT HANDLE (M12xP1.75)	1
14	PANHEAD TAPPING SCREW (M4x8)	4	72	PANHEAD MACHINE SCREW (M4x16xP0.7)	4
15	BRUSH SPRING (0.4x4x3T)	2	73	UNIVERSAL PORT	1
16	CARBON BRUSH HOLDER (7x17)	2	74	O-RING (Ø22xØ25x1.5)	1
17	INSULATION PLATE (10x38x1)	2	75	VACUUM ADAPTOR	1
19	PANHEAD MACHINE SCREW (M4x6xP0.7)	2	77	WATER COUPLING (1/2")	1
20	SPIRIT LEVEL (10x10x29)	1	78	PLUG	1
21	MOTOR HOUSING	1	79	CLUTCH DISC SET	1
23	PANHEAD TAPPING SCREW (3/16"x3")	2	80	O-RING (Ø32x1.5)	1
24	FAN SHROUD	1	81	PILOT DRILL SOCKET	1
25	BALL BEARING (6200)	1	82	SELECTOR DISC	1
26	ARMATURE (110V/220V-81x45.8x60)	1	83	SPINDLE (1 1/4"-7x1/2"BSP-224.5MM)	1
27	BALL BEARING (6201)	1	83	SPINDLE (1/2"BSP-191.5MM)	1
30	GEAR PLATE	1	83	SPINDLE (M18xP2.5-191.5MM)	1
30-2	CAM PLATE-Normal	1	83	SPINDLE (M18xP1.5-192.5MM)	1
31	GASKET	1	83	SPINDLE (1 1/4"-7x1/2"BSP-207.5MM)	1
32	BALL BEARING (608)	1	84	STAINLESS BUSHING	2
33	CLUTCH NUT (M10xP1.25x8.1T)	1	85	FLAG TERMINAL	1
35	PRESSURE DISC (Ø12.1xØ28x2.65)	1	86	HAND KNOB	1
37	INPUT GEAR (M1.0x34T)	1	87	HEX BOLT (M6x60xP1.0)	1
40	INPUT SHAFT (DP20x21TxM1.25x14T)	1	88	POWER SUPPLY CABLE	1
41	NEEDLE BEARING (HK 0810)	1	89	BUSHING (Ø12xØ18x4.2)	1
42	NEEDLE BEARING (HK 1010)	1	90	GEAR PLATE	1
44	SPRING (Ø1.1xØ17xØ19.2x3.5Tx15L)	1	91	FRONT HANDLE (M12xP1.75)	1
45	CAM PLATE (B)	1	92	GEAR PLATE	1
47	SLIDER GEAR-AB (DP20x32TxM1.25x41T)	1	92-2	CAM PLATE (A)	1
48	GEAR HOUSING	1	93	CAM PLATE (B)	1
49	SOCKET CAP SCREW (M5x12xP0.8)	1	94	WATER FEED CONNECTOR KIT	1
52	O-RING (Ø20x3)	1	95	STATOR (110V/220V-81x45.6x60)	1
53	GEAR SELECTOR	1	96	CARBON BRUSH (7x17x19)/(110V/220V)	2
54	SPRING (Ø0.6xØ3.8xØ5x11Tx35L)	1			

# DM52P Exploded View

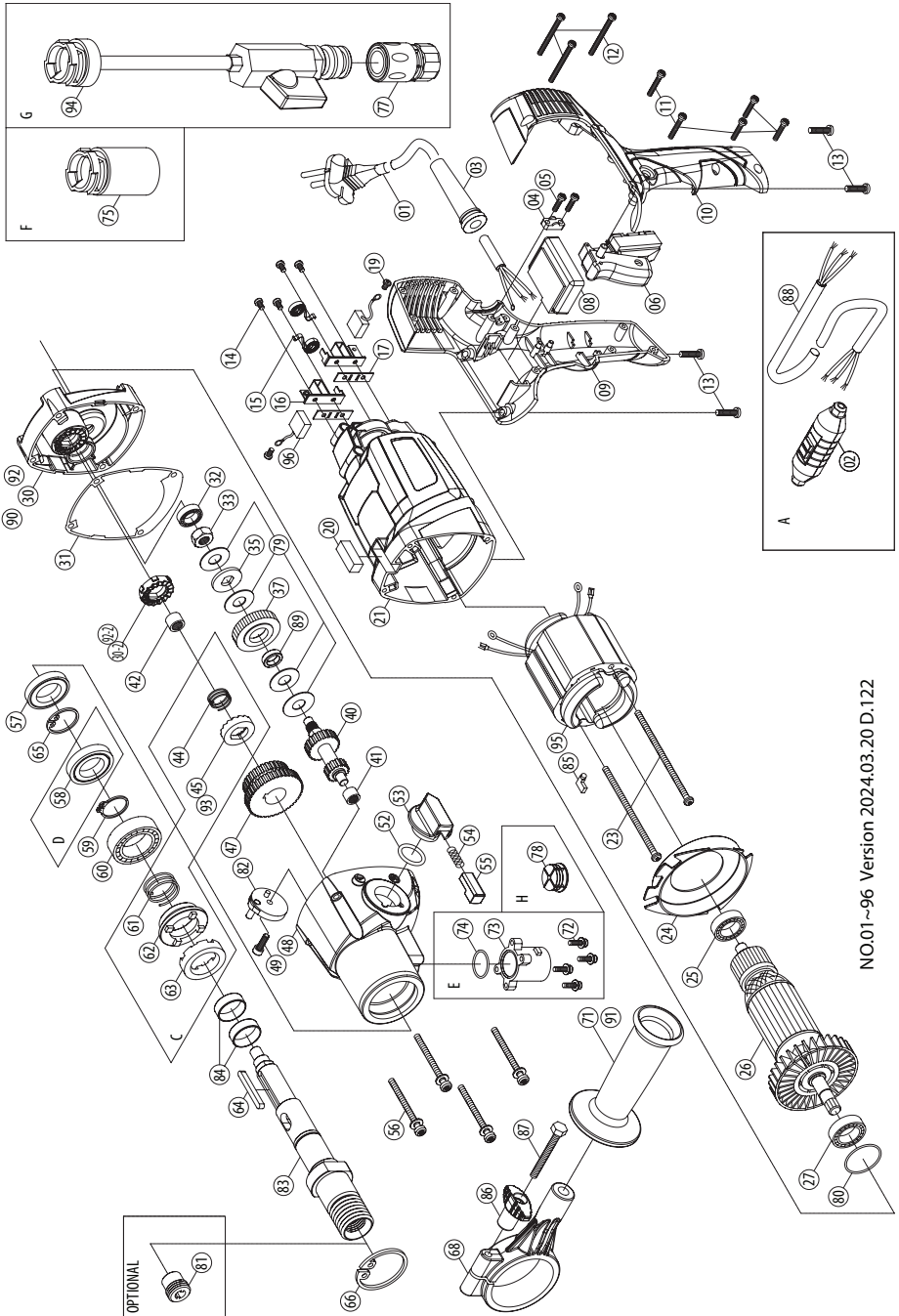

NO.01~96 Version 2024.03.20 D:122

## DM52P Parts List

NO.	Parts Name	QTY	NO.	Parts Name	QTY
1	POWER SUPPLY CABLE (UK-1.5x3Cx3M-H07RNF)	1	54	SPRING (Ø0.6xØ3.8xØ5x11Tx35L)	1
1	POWER SUPPLY CABLE (VDE-1.0x2Cx3M-H07RNF)	1	55	RELEASE PIN	1
1	POWER SUPPLY CABLE (VDE-1.0x2Cx1.4M-H07RNF)	1	56	TORX PANHEAD TAPPING SCREW (M5x60)	4
2	PRCD INTERRUPTER PROTECTION (110V/220V)	1	57	OIL SEAL (Ø27xØ42x7)	1
3	CORD ARMOR	1	58	OIL SEAL (Ø27xØ45x8)	1
4	CABLE CLIP	1	59	INTERNAL CIRCLIP (IS28)	1
5	PANHEAD TAPPING SCREW (M4x14)	2	60	BALL BEARING (60/28)	1
6	SWITCH (110V&220V)	1	61	SPRING (Ø1.2xØ28.2xØ30.6x5Tx40L)	1
7	TERMINAL CONNECTOR BLOCK (PA-8-H)	1/12	62	IMPACT SELECTOR COLLAR	1
8	ELECTRONICS UNIT (110V/220V)/(110V/220V-AVR)	1	63	ENGAGEMENT COLLAR	1
9	HANDLE HALF-RIGHT	1	64	PARALLEL KEY (5x5x45)	1
10	HANDLE HALF-LEFT	1	65	INTERNAL CIRCLIP (R-42)	1
11	PANHEAD TAPPING SCREW (M4x20)	5	66	INTERNAL CIRCLIP (R-52)	1
12	PANHEAD TAPPING SCREW (M4x35)	3	68	HANDLE CLAMP	1
13	TORX PANHEAD TAPPING SCREW (M5x20)	4	71	FRONT HANDLE (M12xP1.75)	1
14	PANHEAD TAPPING SCREW (M4x8)	4	72	PANHEAD MACHINE SCREW (M4x16xP0.7)	4
15	BRUSH SPRING (0.4x4x3T)	2	73	UNIVERSAL PORT	1
16	CARBON BRUSH HOLDER (7x17)	2	74	O-RING (Ø22xØ25x1.5)	1
17	INSULATION PLATE (10x38x1)	2	75	VACUUM ADAPTOR	1
19	PANHEAD MACHINE SCREW (M4x6xP0.7)	2	77	WATER COUPLING (1/2")	1
20	SPIRIT LEVEL (10x10x29)	1	78	PLUG	1
21	MOTOR HOUSING	1	79	CLUTCH DISC SET	1
23	PANHEAD TAPPING SCREW (3/16"x3")	2	80	O-RING (Ø32x1.5)	1
24	FAN SHROUD	1	81	PILOT DRILL SOCKET	1
25	BALL BEARING (6200)	1	82	SELECTOR DISC	1
26	ARMATURE (110V/220V-81x45.8x60)	1	83	SPINDLE (1 1/4"-7x1/2"BSP-224.5MM)	1
27	BALL BEARING (6201)	1	83	SPINDLE (1/2"BSP-191.5MM)	1
30	GEAR PLATE	1	83	SPINDLE (M18xP2.5-191.5MM)	1
30-2	CAM PLATE-Normal	1	83	SPINDLE (M18xP1.5-192.5MM)	1
31	GASKET	1	83	SPINDLE (1 1/4"-7x1/2"BSP-207.5MM)	1
32	BALL BEARING (608)	1	84	STAINLESS BUSHING	2
33	CLUTCH NUT (M10xP1.25x8.1T)	1	85	FLAG TERMINAL	1
35	PRESSURE DISC (Ø12.1xØ28x2.65)	1	86	HAND KNOB	1
37	INPUT GEAR (M1.0x34T)	1	87	HEX BOLT (M6x60xP1.0)	1
40	INPUT SHAFT (DP20x21TxM1.25x14T)	1	88	POWER SUPPLY CABLE	1
41	NEEDLE BEARING (HK 0810)	1	89	BUSHING (Ø12xØ18x4.2)	1
42	NEEDLE BEARING (HK 1010)	1	90	GEAR PLATE	1
44	SPRING (Ø1.1xØ17xØ19.2x3.5Tx15L)	1	91	FRONT HANDLE (M12xP1.75)	1
45	CAM PLATE (B)	1	92	GEAR PLATE	1
47	SLIDER GEAR-AB (DP20x32TxM1.25x41T)	1	92-2	CAM PLATE (A)	1
48	GEAR HOUSING	1	93	CAM PLATE (B)	1
49	SOCKET CAP SCREW (M5x12xP0.8)	1	94	WATER FEED CONNECTOR KIT	1
52	O-RING (Ø20x3)	1	95	STATOR (110V/220V-81x45.6x60)	1
53	GEAR SELECTOR	1	96	CARBON BRUSH (7x17x19)/(110V/220V)	2

