

# AGP<sup>®</sup>

## Low Profile Magnetic Core Drill

PMD3530



**Instruction Manual**  
**CE CB**



## TECHNICAL DATA

|                                       |   |                                 |
|---------------------------------------|---|---------------------------------|
| Power Input                           | 1100 W  |                                 |
| Voltage                               | 220-240 V~ 50-60 Hz, or 110-120 V~ 50-60 Hz (See Machine Nameplate) |                                 |
| No Load / Full Load min <sup>-1</sup> | 650 / 390   |                                 |
| Capacity                              | Ø x Depth of Cut  | 35 mm x 35 mm (1-3/8" x 1-3/8") |
| Cutter Shank                          | 19.05 mm (3/4") Weldon  |                                 |
| Magnetic Adhesion                     | 15,000 N  |                                 |
| Dimensions (L x W x H)                | 300 x 101 x 200 mm (w/o handle)                                     |                                 |
| Net weight                            | 10.5 kg (23.1 lb)   |                                 |

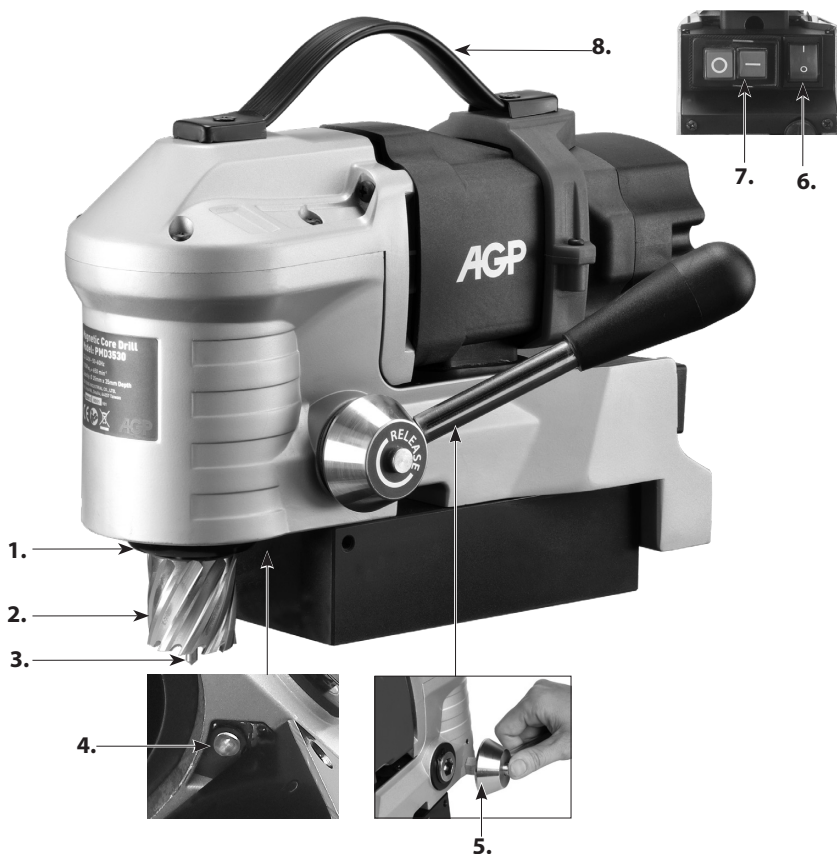

- 1. Quick-Release Tool Holder
- 2. Annular Cutter (Not Included)
- 3. Pilot Pin (Not Included)
- 4. LED Work Light

- 5. Crank Lever
- 6. Magnet Switch
- 7. Motor Switch
- 8. Carrying Strap

### STANDARD ACCESSORIES

- \* Safety Belt
- \* Chip Guard Kit

### OPTIONAL ACCESSORIES:

- \* Overload Protection

## GENERAL SAFETY INSTRUCTIONS



**WARNING! Read all safety warnings and all instructions.** Failure to follow the warnings and instructions may result in electric shock, fire and/or serious injury.

**Save all warnings and instructions for future reference.** The term “power tool” in the warnings refers to your mains operated (corded) power tool or battery-operated (cordless) power tool.

### 1) WORK AREA SAFETY

- a. **Keep work area clean and well lit.** Cluttered or dark areas invite accidents.
- b. **Do not operate power tools in explosive atmospheres, such as in the presence of flammable liquids, gases or dust.** Power tools create sparks which may ignite the dust or fumes.
- c. **Keep children and bystanders away while operating a power tool.** Distractions can cause you to lose control.
- d. **Never leave the electric power tool unattended.** Only leave the machine when the tool in use has come to a complete standstill.

### 2) ELECTRICAL SAFETY

- a. **Power tool plugs must match the outlet. Never modify the plug in any way. Do not use any adapter plugs with earthed (grounded) power tools.** Unmodified plugs and matching outlets will reduce risk of electric shock.
- b. **Avoid body contact with earthed or grounded surfaces such as pipes, radiators, ranges and refrigerators.** There is an increased risk of electric shock if your body is earthed or grounded.
- c. **Do not expose power tools to rain or wet conditions.** Water entering a power tool will increase the risk of electric shock.
- d. **Do not abuse the cord. Never use the cord for carrying, pulling or unplugging the power tool. Keep cord away from heat, oil, sharp edges or moving parts.** Damaged or entangled cords increase the risk of electric shock.
- e. **When operating a power tool outdoors, use an extension cord suitable for outdoor use.** Use of a cord suitable for outdoor use reduces the risk of electric shock.
- f. **If operating a power tool in a damp location is unavoidable, use an earth leakage circuit breaker.** Use of an earth leakage circuit breaker reduces the risk of electric shock.

### 3) PERSONAL SAFETY

- a. **Stay alert, watch what you are doing and use common sense when operating a power tool. Do not use a power tool while you are tired or under the influence of drugs, alcohol or medication.** A moment of inattention while operating power tools may result in serious personal injury.
- b. **Use personal protective equipment. Always wear eye protection.** Protective equipment such as dust mask, non-skid safety shoes, hard hat, or hearing protection used for appropriate conditions will reduce personal injuries.
- c. **Prevent unintentional starting. Ensure the switch is in the off-position before connecting to power source and/or battery pack, picking up or carrying the tool.** Carrying power tools with your finger on the switch or energising power tools that have the switch on invites accidents.

- d. **Remove any adjusting key or wrench before turning the power tool on.** A wrench or a key left attached to a rotating part of the power tool may result in personal injury.
- e. **Do not overreach. Keep proper footing and balance at all times.** This enables better control of the power tool in unexpected situations.
- f. **Dress properly. Do not wear loose clothing or jewelry. Keep your hair, clothing and gloves away from moving parts.** Loose clothes, jewelry or long hair can be caught in moving parts.
- g. **If devices are provided for the connection of dust extraction and collection facilities, ensure these are connected and properly used.** Use of dust collection can reduce dust-related hazards.
- h. **Do not let familiarity gained from frequent use of tools allow you to become complacent and ignore tool safety principles.** A careless action can cause severe injury within a fraction of a second.

#### 4) POWER TOOL USE AND CARE

- a. **Do not force the power tool. Use the correct power tool for your application.** The correct power tool will do the job better and safer at the rate for which it was designed.
- b. **Do not use the power tool if the switch does not turn it on and off.** Any power tool that cannot be controlled with the switch is dangerous and must be repaired.
- c. **Disconnect the plug from the power source and/or the battery pack from the power tool before making any adjustments, changing accessories, or storing power tools.** Such preventive safety measures reduce the risk of starting the power tool accidentally.
- d. **Store idle power tools out of the reach of children and do not allow persons unfamiliar with the power tool or these instructions to operate the power tool.** Power tools are dangerous in the hands of untrained users.
- e. **Maintain power tools. Check for misalignment or binding of moving parts, breakage of parts and any other condition that may affect the power tool's operation. If damaged, have the power tool repaired before use.** Many accidents are caused by poorly maintained power tools.
- f. **Keep cutting tools sharp and clean.** Properly maintained cutting tools with sharp cutting edges are less likely to bind and are easier to control.
- g. **Use the power tool, accessories and tool bits etc., in accordance with these instructions, taking into account the working conditions and the work to be performed.** Use of the power tool for operations different from those intended could result in a hazardous situation.
- h. **Keep handles and grasping surfaces dry, clean and free from oil and grease.** Slippery handles and grasping surfaces do not allow for safe handling and control of the tool in unexpected situations.

#### 5) SERVICE

**Have your power tool serviced by a qualified repair person using only identical replacement parts.** This will ensure that the safety of the power tool is maintained.

## Symbols used in this manual

V.....volts

A.....amperes

Hz.....hertz

W.....watt

~.....alternating current

$n_0$ .....no load speed

$\text{min}^{-1}$ .....revolutions or reciprocation  
per minute



.....warning of general danger



.....with electrical earth



.....read these instructions



.....always wear eye protection



.....always wear a dust mask.



.....always wear hearing protection



.....wear safety-approved hard hat



do not dispose of electric tools,  
accessories and packaging together  
with household waste material

## TERMINOLOGY USED IN THE MANUAL

- 1. Warning:** This term means that there is a risk of physical harm or death to the operator or people nearby.
- 2. Caution:** This term means that there is a risk of damage to the machine, cutting tool or other equipment.
- 3. Note:** These terms offer useful information relating to the operation of the machine or its maintenance.

## SPECIFIC SAFETY RULES AND REGULATIONS

**WARNING:** For your own safety, never use coolant containing water while operating at more than a 90 degrees from horizontal. Spray-type or paste-type coolants which do not contain water should be used !

- 1. Always use safety strap.** Mounting can release.
- 2. The magnet's adhesion depends on the thickness of the work piece.** Always ensure that the work piece is a minimum of 12mm (7/16 in.) thick. If it is not, then use a piece of steel plate at least 12mm thick and larger than the magnet below the work piece to supplement the magnetic adhesion.
- 3. Metal chips and other debris will seriously hamper magnetic adhesion.** Always ensure that the magnet is clean.
- 4. Other units used on the same receptacle will cause uneven voltage that could lead to the magnet releasing.** Always use the tool alone on the receptacle.
- 5. It is hazardous to use the drill upside-down.** Do not exceed 90 degrees from horizontal.
- 6. Avoid the magnet releasing.** Ensure that the magnet has properly adhered to the work piece before beginning drilling.
- 7. Avoid operating annular cutters without coolant.** Always lubricate the cutter and add as needed during the cut. Always lubricate the cutter and add as needed during the cut.

- 8. Do not operate with dull or damaged cutting tools. This may overload the motor. Protect the motor.** Never allow cutting fluid, water, or other contaminants enter the motor.
- 9. Metal chips are often very sharp and hot.** Never touch them with bare hands. Clean up with a magnetic chip collector and a chip hook or other appropriate tool.
- 10. Chip guard must be used.** To attach the chip guard, use the supplied butterfly bolts to bolt to the magnet. It is not necessary to remove guard to clean chips. Simply raise guard to its upper position.

**CAUTION: NEVER position machine on a work piece between the electrode and the ground of any arc type welder. Damage to the machine will result, as the welder will ground through the machine's ground cable.**

**WARNING: NEVER attempt to use machine with incorrect current or abnormally low voltage. Check machine nameplate to ensure that correct voltage and Hz are used.**

## USING THE SAFETY STRAP

The safety strap must always be used.

Loop the strap through the slot above the magnet and around the workpiece. Push on the spring buckle and thread the loose end of the strap through the loop and pull tight. Push on the spring buckle to release strap.

## MOUNTING ANNULAR CUTTERS

**CAUTION: Never use a cutting tool that is larger than the maximum rated capacity of the machine.**

- To insert an annular cutter, first insert the pilot pin into the cutter.
- Whenever mounting or removing cutters, always unplug the machine.
- Lower the arbor.
- Push up on the quick-release collar. Insert the cutter with pilot pin and turn until the flat meets the locking pin. When the flat meets the locking pin, the collar will snap down. Double check to ensure that it is fully locked.
- To remove, lower the arbor, push up on the quick-release collar and remove the cutter.



## OPERATION-GENERAL

**WARNING: Always ensure that the magnet is adhered properly to the work piece before beginning drilling.**

**NOTE: If mounting to a curved surface beam, mount the machine parallel to the curve in the work piece.**

**WARNING: Avoid operating at more than 90 degrees from horizontal. When drilling at such an angle take precautions to prevent cutting coolant from entering the motor. Paste-type stick lubricant should be used.**

1. First fit tool into arbor and line up with intended center of cut. Then switch magnet on.
2. Press green motor on button to start motor. Use the crank handle to feed to work. Always use very light pressure when beginning the cut and just as the tool is breaking through. The crank handle offers tremendous leverage; so do not use too much force. Allow the cutting tool to determine the pace. With experience, the operator will be able to determine the best pace to feed to the work. There should be some degree of audible slowing of the motor but not bogging in the cut. Correct cutting speed with a properly sharp annular cutter will produce long unbroken chips, which produce a "bird's nest" shaped bundle of chips around the cut.

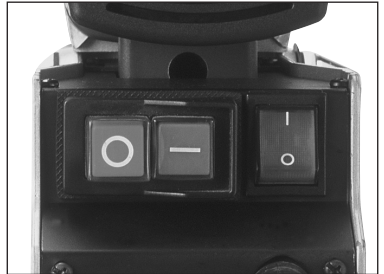

**NOTE: Always ensure that the cutting tool is sharp. A dull cutter typically will have finer and/or choppy shavings.**

**WARNING: ALWAYS clear chips when there is too much build-up. Excessive chip build-up could result in a jammed cutter or other hazardous situation.**

**WARNING: the slug ejects at end of cut and is very hot. Always provide a method of catching the slug, where the ejected slug may cause injury to people below.**

**CAUTION: Never attempt to cut half-circles or to stitch drill (drill overlapping holes) with a TCT cutter. This may destroy the cutter.**

**CAUTION: Do not leave the magnet on for extended periods of time. This will lead to overheating of the coils and subsequent early failure. Only turn the magnet on when you are ready to drill and turn back off when you are done.**

## **MAGNET BASE DUTY CYCLE**

Do not leave the magnet base activated continuously for more than 60 minutes. If the magnet base is overheated, allow it to cool for 30 minutes before continuing. This machine is not intended for production-line type use.

## REVERSING OR CHANGING THE POSITION OF THE CRANK LEVER

The Crank Lever is quick-release and adjustable to suit different operating conditions.

If it is required to mount the crank lever on the opposite side or to change its position, push the Release Button in the center of the Crank Hub and remove. Press the Button and mount on the opposite side or in the desired position.

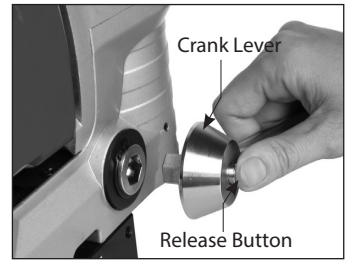

## THE OPTIONAL LED WORK LIGHT

Models equipped with the optional LED WORK LIGHT have a light which is always on whenever the machine is plugged in. This can be useful when working in dark work spaces.

**CAUTION: Never attempt to re enter a half-finished cut if the magnet has been turned off and the machine shifted in the interim. This may destroy the cutter.**

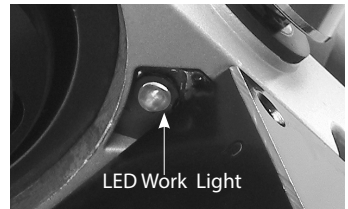

## MAINTENANCE

Every 50 hours of operation blow compressed air through the motor while running at no load to clean out accumulated dust. (If operating in especially dusty conditions, perform this operation more often.)

1. Keep the machine clean and free of chips.
2. Check for loose fittings and tighten as needed.
3. Ensure that the ventilation slots are clear so that motor can be cooled normally. Blow low-pressure compressed air through the ventilation slots with the motor running to keep motor clean.

## THE ARBOR SHAFT

Keep the arbor shaft free of dirt and lightly grease as needed. If the mechanism noisy, it may be dirty or have a chip lodged in it. Clean and re-grease as needed.

## THE CARBON BRUSHES

The carbon brushes are a normal wearing part and must be replaced when they reach their wear limit.

**Caution: Always replace the brushes as a pair.**



## To replace:

1. Remove the 4 screws and remove the motor tail cover.
2. Using pliers rotate the brush spring out of the way and slide the old carbon brush out of the brush holder.
3. Unscrew the screw to remove the brush lead. The old carbon brush may now be lifted away.
4. Install a new brush. Installation is the reverse of removal.
5. Replace the motor tail cover.

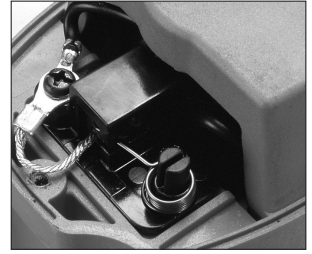

## CARBON BRUSHES

Due to the brush design, if the machine comes to a stop without any reason, the brushes have to be checked. The brush design stops the machine before the carbon brushes are finished and protects the motor.

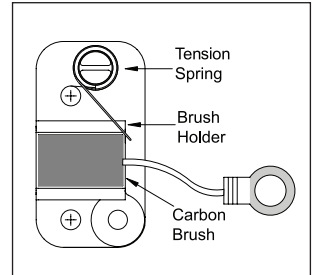

## MAGNET TROUBLESHOOTING

Full magnet performance is absolutely essential for magnetic drill operation.

If the magnet works, but does not hold well, it is likely that one of the coils has failed. If the magnet does not work at all, it is likely to be a failed rectifier. (It is highly unlikely that both magnet coils would fail at the same time)

NOTE: A faulty magnet coil can also damage the rectifier, so whenever there is a magnet problem, BOTH the magnet coils and rectifier must be checked.

WARNING: Never attempt to operate a magnetic drill with a faulty magnet!

## CHECKING THE MAGNET (qualified technicians only)

If the magnet is not working well, it must be checked. Separate the wires of each individual coil and test the resistance of each coil separately. (note that 110V models are wired in parallel and 230V models are wired in series) The resistance of the coils of different sizes of magnets varies, but it should be in the region of hundreds of ohms. Most importantly, both coils must have very nearly the same resistance. If one of the coils has zero resistance, it means that it is shorted. If one of the coils has infinite resistance, it means that the circuit is broken. If either coil has a problem, the magnet must be replaced. A faulty magnet may also cause damage to the rectifier. Also check the rectifier when replacing a faulty magnet. (see below)

## CHECKING THE RECTIFIER (Qualified technicians only)

The rectifier takes the AC household current and converts it to DC to power the magnet. If it fails, the magnet coils will not receive power.

Disconnect the rectifier and test the resistance of both circuits of the rectifier between the AC and the DC sides.

Note that polarity matters, so you can only take a reading if test probes are oriented correctly. Each side will be the opposite of the other. Both circuits should have very nearly the same resistance reading. If one of the circuits has zero resistance, it means that it is shorted. If one of the circuits has infinite resistance, it means that the circuit is broken.

**If the replacement of the power supply cord is necessary, this has to be done by the manufacturer or their agent in order to avoid a safety hazard.**

**WARNING: All repairs must be entrusted to an authorized service center.** Incorrectly performed repairs could lead to injury or death.

# Wiring

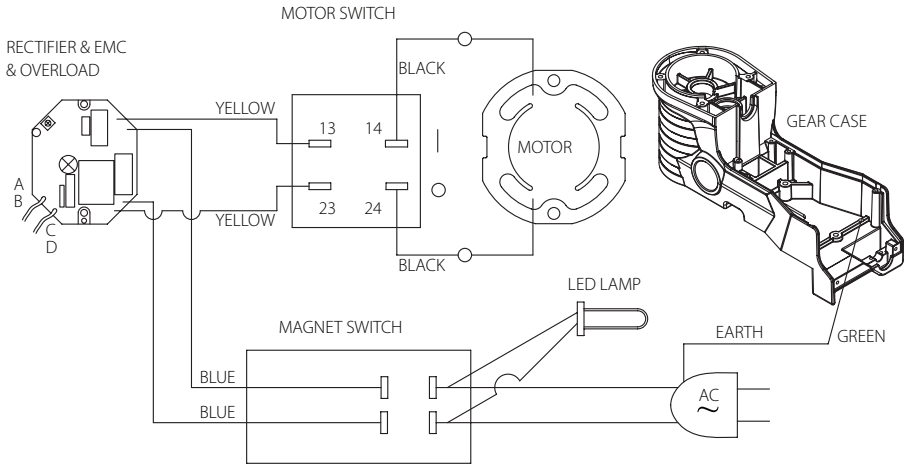
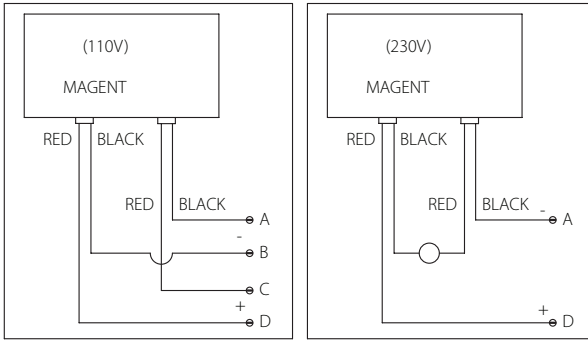

# Wiring

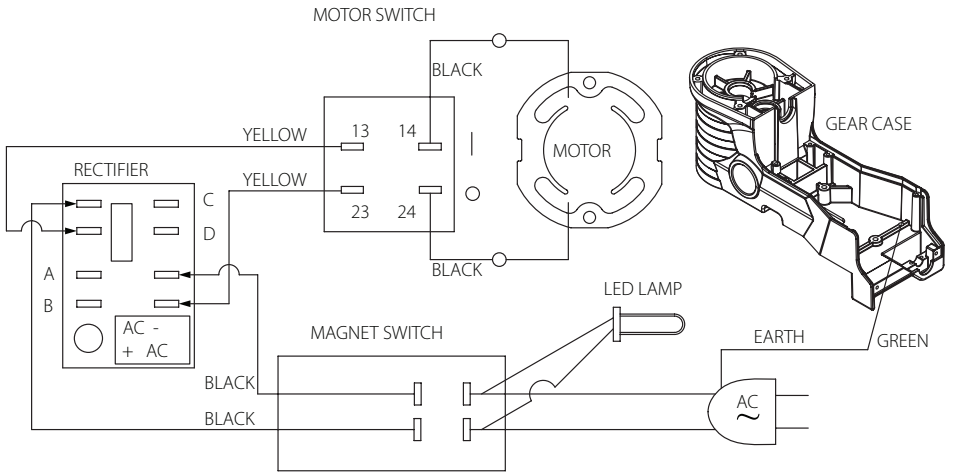
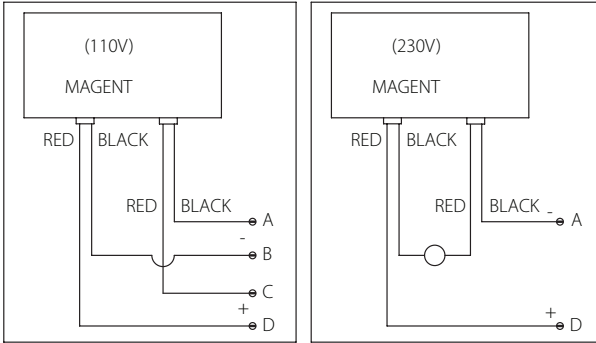

# Wiring

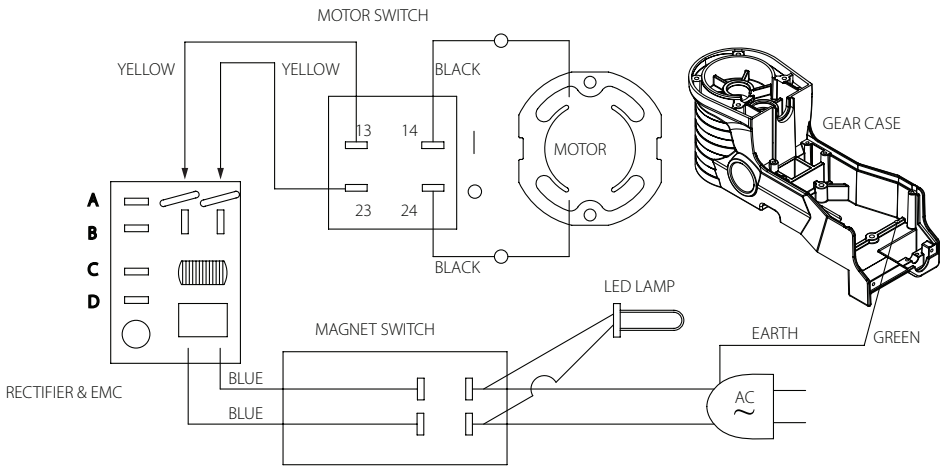
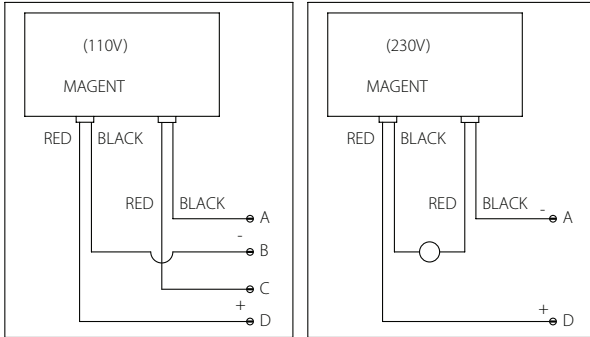

# Exploded View

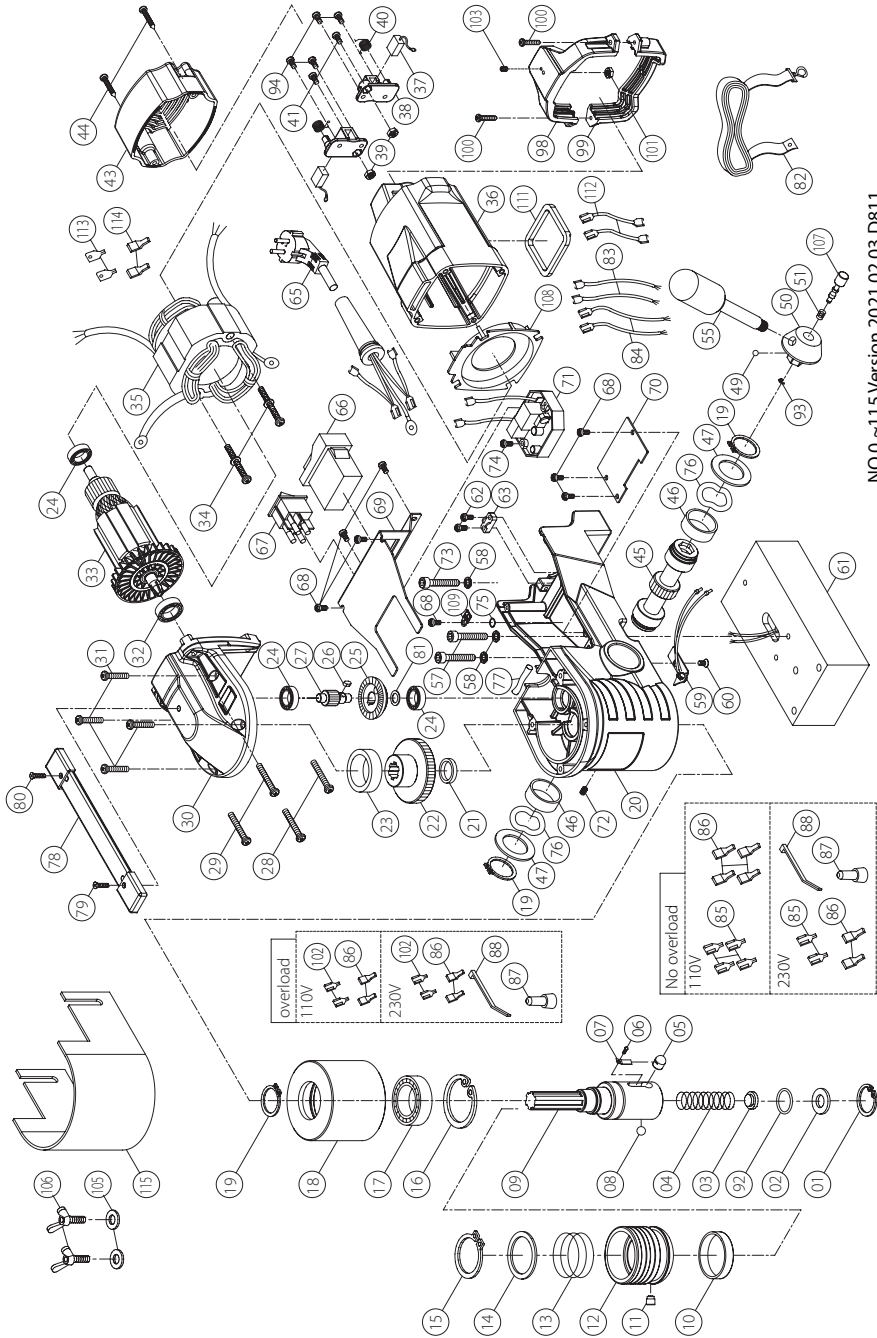

NO.0~115 Version 2021.02.03.D811

## Parts list

| NO. | Parts Name                         | QTY | NO. | Parts Name                             | QTY |
|-----|------------------------------------|-----|-----|--|-----|
| 1   | INTERNAL CIRCLIP (R-19)            | 1   | 59  | LED LAMP                               | 1   |
| 2   | FLAT WASHER (Ø10xØ18.5x0.8)        | 1   | 60  | FLAT HEAD MACHINE SCREW (M4x6xP0.7)    | 1   |
| 3   | WATER SEAL (Ø12x15)                | 1   | 61  | ELECTROMAGNET (164x80x48)              | 1   |
| 4   | SPRING (Ø1.2xØ10xØ12.4x11Tx54L)    | 1   | 62  | PANHEAD MACHINE SCREW (M4x12xP0.7)     | 2   |
| 5   | LOCK PIN (12.3MM)/(11.7MM)         | 1   | 63  | CABLE CLIP                             | 1   |
| 6   | PANHEAD MACHINE SCREW (M3x4xP0.5)  | 1   | 65  | POWER SUPPLY CABLE                     | 1   |
| 7   | LOCK PIN SPRING                    | 1   | 66  | MOTOR SWITCH (110V/220V)               | 1   |
| 8   | CHECK BALL (Ø8)                    | 1   | 67  | MAGNET SWITCH (110V&220V)              | 1   |
| 9   | SPINDLE (141MM)                    | 1   | 68  | PANHEAD MACHINE SCREW (M4x8xP0.7)      | 8   |
| 10  | RING (Ø40xØ44x9)                   | 1   | 69  | SWITCH BRACKET                         | 1   |
| 11  | COLLAR PIN (Ø8)                    | 1   | 70  | MOUNTING PLATE                         | 1   |
| 12  | QUICK-RELEASE COLLAR               | 1   | 71  | RECTIFIER (110&220V)                   | 1   |
| 13  | SPRING (Ø2.3xØ39xØ43.6x3Tx30L)     | 1   | 71  | RECTIFIER & EMC (110V)                 | 1   |
| 14  | SPRING SEAT RING (Ø35.1xØ44.5x2)   | 1   | 71  | RECTIFIER & EMC (110V&220V)            | 1   |
| 15  | EXTERNAL CIRCLIP (S-35)            | 1   | 71  | RECTIFIER & EMC & OVERLOAD (110V/220V) | 1   |
| 16  | INTERNAL CIRCLIP (R-47)            | 1   | 72  | SOCKET SET SCREW (M5x10xP0.8)          | 1   |
| 17  | BALL BEARING (6005)                | 1   | 73  | SOCKET CAP SCREW (M6x16xP1.0)          | 1   |
| 18  | QUILL TUBE                         | 1   | 74  | PANHEAD MACHINE SCREW (M4x16xP0.7)     | 1   |
| 19  | EXTERNAL CIRCLIP (S-25)            | 3   | 75  | EXTERNAL STAR WASHER (M5)              | 1   |
| 20  | GEAR PLATE                         | 1   | 76  | WAVE SPRING WASHER (Ø30xØ38.5)         | 2   |
| 21  | BUSHING (Ø18xØ23x4)                | 1   | 77  | SEAL(5CM)                              | 1   |
| 22  | OUTPUT GEAR (M1.25x47T)            | 1   | 78  | STRAP COVER                            | 1   |
| 23  | BUSHING (Ø30xØ36x12)               | 1   | 79  | FLAT HEAD MACHINE SCREW (M5x15xP0.8)   | 1   |
| 24  | BALL BEARING (608)                 | 3   | 80  | FLAT HEAD MACHINE SCREW (M5x20xP0.8)   | 1   |
| 25  | BEVEL GEAR (M1.0x46T)              | 1   | 81  | BEVEL WASHER (Ø10.1xØ14x1.2)           | 1   |
| 26  | PARALLEL KEY (4x4x7)               | 1   | 82  | SAFETY BELT                            | 1   |
| 27  | INPUT SHAFT (M1.25x9T)             | 1   | 83  | WIRE LEAD (1015-16#18CM)               | 2   |
| 28  | PANHEAD TAPPING SCREW (M5x25)      | 2   | 84  | WIRE LEAD (1015-16#18CM)               | 2   |
| 29  | PANHEAD TAPPING SCREW (M5x30)      | 2   | 85  | FEMALE SPADE TERMINAL                  | 4   |
| 30  | GEAR HOUSING (SILVER)              | 1   | 86  | SPADE TERMINAL BOOT                    | 6   |
| 31  | PANHEAD MACHINE SCREW (M5x25xP0.8) | 4   | 87  | CRIMP CAP CONNECTOR (C4)               | 1   |
| 32  | BALL BEARING (6001)                | 1   | 88  | ZIP TIE (2.5x100MM)                    | 1   |
| 33  | ARMATURE (110V/220V-73x42x45)      | 1   | 92  | O-RING (Ø12x4)                         | 1   |
| 34  | PANHEAD TAPPING SCREW (M5x60)      | 2   | 93  | E-CLIP (E-3)                           | 1   |
| 35  | STATOR (110V/220V-73x42x45)        | 1   | 94  | PANHEAD TAPPING SCREW (M4x12)          | 4   |
| 36  | MOTOR HOUSING                      | 1   | 98  | BRACKET-TOP                            | 1   |
| 37  | CARBON BRUSH (7x11x17)             | 2   | 99  | BRACKET-BOTTOM                         | 1   |
| 38  | CARBON BRUSH HOLDER (7x11)         | 2   | 100 | PANHEAD TAPPING SCREW (M4x16)          | 2   |
| 39  | HEX NUT (M4xP0.7)                  | 2   | 101 | HEX NUT (M5xP0.8)                      | 1   |
| 40  | BRUSH SPRING (0.35x3x3T)           | 2   | 102 | FEMALE SPADE TERMINAL                  | 2   |
| 41  | PANHEAD MACHINE SCREW (M4x10xP0.7) | 2   | 103 | SOCKET SET SCREW (M4x8xP0.7)           | 1   |
| 43  | MOTOR TAIL CASTING                 | 1   | 105 | FLAT WASHER (Ø6xØ13x1)                 | 2   |
| 44  | PANHEAD TAPPING SCREW (M4x25)      | 2   | 106 | BUTTERFLY SCREW (M6x10xP1.0)           | 2   |
| 45  | CRANK SPINDLE (Ø28)                | 1   | 107 | PLUNGER                                | 1   |
| 46  | BUSHING (Ø28xØ32x12)               | 2   | 108 | FAN SHROUD                             | 1   |
| 47  | PRESSURE DISC (Ø25.5xØ40x2)        | 2   | 109 | EARTHING MARKING                       | 1   |
| 49  | CHECK BALL (Ø5)                    | 1   | 111 | SEAL                                   | 1   |
| 50  | CRANK HUB                          | 1   | 112 | WIRE LEAD (1015-16#9CM)                | 2   |
| 51  | SPRING (Ø0.6xØ4.1xØ5.3x4Tx6.5L)    | 1   | 113 | MALE SPADE TERMINAL                    | 2   |
| 55  | CRANK HANDLE                       | 1   | 114 | TERMINAL COVER                         | 2   |
| 57  | SOCKET CAP SCREW (M6x30xP1.0)      | 2   | 115 | CHIP GUARD                             | 1   |
| 58  | SPRING WASHER (M6)                 | 3   |     |  |     |

