

AGP

Straight Grinder

SG6



Instruction Manual

CE CB 



Power input	110-120 V : 1400 W, 220-240 V : 1500 W
Voltage	See machine nameplate
No Load Speeds	1600 ~ 4800 min ⁻¹
Spindle	M14 (16 mm Tool Holder), M12 (12.7 mm (1/2") Tool Holder), or 5/8"-11 (7/8" Tool Holder) (See machine nameplate)
Max. Wheel Thickness	32 mm (1-1/4")
Max. Wheel Diameter	150 mm (6")
Weight	3.4 kg (7.5 lb)

Summary of compliance with National Differences (List of countries addressed):

This tool is tested to and complies with EN 62841-1:2015 and EN IEC 62841-2-3:2021+A11:2021, thus complying with the EU group differences.

Noise level: $L_{PA} = 88,0 \text{ db (A)}$ $L_{WA} = 96,0 \text{ db (A)}$ $K = 3,0 \text{ db (A)}$

Vibration level: $a_{h,SG} = 7,7 \text{ m/s}^2$ $K = 1,5 \text{ m/s}^2$



- 1. Variable Speed Wheel
- 2. Guard
- 3. Hand Grip
- 4. Trigger Switch
- 5. Release Button

GENERAL POWER TOOL SAFETY WARNINGS



WARNING Read all safety warnings, instructions, illustrations and specifications provided with this power tool. Failure to follow all instructions listed below may result in electric shock, fire and/or serious injury.

Save all warnings and instructions for future reference.

The term "power tool" in the warnings refers to your mains-operated (corded) power tool or battery-operated (cordless) power tool.

1) WORK AREA SAFETY

- a. **Keep work area clean and well lit.** Cluttered or dark areas invite accidents.
- b. **Do not operate power tools in explosive atmospheres, such as in the presence of flammable liquids, gases or dust.** Power tools create sparks which may ignite the dust or fumes.
- c. **Keep children and bystanders away while operating a power tool.** Distractions can cause you to lose control.

2) ELECTRICAL SAFETY

- a. **Power tool plugs must match the outlet. Never modify the plug in any way. Do not use any adapter plugs with earthed (grounded) power tools.** Unmodified plugs and matching outlets will reduce risk of electric shock.
- b. **Avoid body contact with earthed or grounded surfaces, such as pipes, radiators, ranges and refrigerators.** There is an increased risk of electric shock if your body is earthed or grounded.
- c. **Do not expose power tools to rain or wet conditions.** Water entering a power tool will increase the risk of electric shock.
- d. **Do not abuse the cord. Never use the cord for carrying, pulling or unplugging the power tool.** Keep cord away from heat, oil, sharp edges or moving parts. Damaged or entangled cords increase the risk of electric shock.
- e. **When operating a power tool outdoors, use an extension cord suitable for outdoor use.** Use of a cord suitable for outdoor use reduces the risk of electric shock.
- f. **If operating a power tool in a damp location is unavoidable, use a residual current device (RCD) protected supply.** Use of an RCD reduces the risk of electric shock.

3) PERSONAL SAFETY

- a. **Stay alert, watch what you are doing and use common sense when operating a power tool. Do not use a power tool while you are tired or under the influence of drugs, alcohol or medication.** A moment of inattention while operating power tools may result in serious personal injury.
- b. **Use personal protective equipment. Always wear eye protection.** Protective equipment such as a dust mask, non-skid safety shoes, hard hat or hearing protection used for appropriate conditions will reduce personal injuries.

- c. **Prevent unintentional starting. Ensure the switch is in the off-position before connecting to power source and/or battery pack, picking up or carrying the tool.** Carrying power tools with your finger on the switch or energising power tools that have the switch on invites accidents.
- d. **Remove any adjusting key or wrench before turning the power tool on.** A wrench or a key left attached to a rotating part of the power tool may result in personal injury.
- e. **Do not overreach. Keep proper footing and balance at all times.** This enables better control of the power tool in unexpected situations.
- f. **Dress properly. Do not wear loose clothing or jewellery. Keep your hair and clothing away from moving parts.** Loose clothes, jewellery or long hair can be caught in moving parts.
- g. **If devices are provided for the connection of dust extraction and collection facilities, ensure these are connected and properly used.** Use of dust collection can reduce dust-related hazards.
- h. **Do not let familiarity gained from frequent use of tools allow you to become complacent and ignore tool safety principles.** A careless action can cause severe injury within a fraction of a second.

4) POWER TOOL USE AND CARE

- a. **Do not force the power tool. Use the correct power tool for your application.** The correct power tool will do the job better and safer at the rate for which it was designed.
- b. **Do not use the power tool if the switch does not turn it on and off.** Any power tool that cannot be controlled with the switch is dangerous and must be repaired.
- c. **Disconnect the plug from the power source and/or remove the battery pack, if detachable, from the power tool before making any adjustments, changing accessories, or storing power tools.** Such preventive safety measures reduce the risk of starting the power tool accidentally.
- d. **Store idle power tools out of the reach of children and do not allow persons unfamiliar with the power tool or these instructions to operate the power tool.** Power tools are dangerous in the hands of untrained users.
- e. **Maintain power tools and accessories. Check for misalignment or binding of moving parts, breakage of parts and any other condition that may affect the power tool's operation. If damaged, have the power tool repaired before use.** Many accidents are caused by poorly maintained power tools.
- f. **Keep cutting tools sharp and clean.** Properly maintained cutting tools with sharp cutting edges are less likely to bind and are easier to control.
- g. **Use the power tool, accessories and tool bits etc. in accordance with these instructions, taking into account the working conditions and the work to be performed.** Use of the power tool for operations different from those intended could result in a hazardous situation.
- h. **Keep handles and grasping surfaces dry, clean and free from oil and grease.** Slippery handles and grasping surfaces do not allow for safe handling and control of the tool in unexpected situations.

5) SERVICE

Have your power tool serviced by a qualified repair person using only identical replacement parts. This will ensure that the safety of the power tool is maintained.

Symbols used in this manual

V.....volts	Always wear eye protection
A.....amperes	Always wear a dust mask.
Hz.....hertz	Always wear hearing protection
W.....watt	Wear safety-approved hard hat
~.....alternating current		DANGER! Keep hands away from cutting area and the blade.
n.....no load speed		do not dispose of electric tools, accessories and packaging together with household waste material
min ⁻¹revolutions or reciprocation per minute	Warning of general danger
	class II tool
	read these instructions

SPECIFIC SAFETY RULES

- 1. Keep hands away from rotating wheel area at all times!**
- 2. Prolonged breathing of airborne dust from grinding operations may effect respiratory function:**
Always use a vacuum cleaner with a bag approved for fine dust installed.
Always wear a respirator approved for dust and mist.
- 3. Grinding LEAD-BASED paint is extremely toxic and should not be attempted.** Only allow professionals with special training and equipment perform this task.
- 4. Maintain proper footing and balance at all times.** Do not overreach.
- 5. Always wear appropriate safety equipment when operating.**
- 6. Important: After completing operation, switch off the switch and wait for the coasting wheel to stop completely before putting the tool down.**
- 7. Never operate the tool in an area with flammable solids, liquids, or gases.** Sparks from the commutator/carbon brushes could cause a fire or explosion.
- 8. There are certain applications for which this tool was designed.** The manufacturer strongly recommends that this tool NOT be modified and/or used for any application other than for which it was designed. If you have any questions relative to its application DO NOT use the tool until you have written the manufacturer and have been advised.
- 9. Use the machine with both hands at all times.** Loss of control can cause personal injury.
- 10. Keep power supply cord clear from the working range of the machine.** Always lead the cable away behind you.
- 11. Immediately switch off the machine if unusual vibrations or if other malfunctions occur.** Check the machine in order to find out the cause.
- 12. The dust that arises when working with this tool can be harmful to health.** Use a dust absorption system and wear a suitable dust protection mask and remove deposited dust with a vacuum cleaner.

SAFETY WARNINGS COMMON FOR GRINDING, POLISHING OR CUTTING-OFF OPERATIONS:

- a. This power tool is intended to function as a grinder, wire brush, polisher, or cut-off tool. Read all safety warnings, instructions, illustrations and specifications provided with this power tool.** Failure to follow all instructions listed below may result in electric shock, fire and/or serious injury.
- b. Operations such as sanding, wire brushing, or hole cutting are not to be performed with this power tool.** Operations for which the power tool was not designed may create a hazard and cause personal injury.
- c. Do not convert this power tool to operate in a way which is not specifically designed and specified by the tool manufacturer.** Such a conversion may result in a loss of control and cause serious personal injury.
- d. Do not use accessories which are not specifically designed and specified by the tool manufacturer.** Just because the accessory can be attached to your power tool, it does not assure safe operation.
- e. The rated speed of the accessory must be at least equal to the maximum speed marked on the power tool.** Accessories running faster than their rated speed can break and fly apart.
- f. The outside diameter and the thickness of your accessory must be within the capacity rating of your power tool.** Incorrectly sized accessories cannot be adequately guarded or controlled.
- g. The dimensions of the accessory mounting must fit the dimensions of the mounting hardware of the power tool.** Accessories that do not match the mounting hardware of the power tool will run out of balance, vibrate excessively, and may cause loss of control.
- h. Do not use a damaged accessory. Before each use inspect the accessory such as abrasive wheels for chips and cracks, backing pad for cracks, tears, or excess wear, wire brush for loose or cracked wires. If power tool or accessory is dropped, inspect for damage or install an undamaged accessory. After inspecting and installing an accessory, position yourself and bystanders away from the plane of the rotating accessory and run the power tool at maximum no-load speed for one minute.** Damaged accessories will normally break apart during this test time.
- i. Wear personal protective equipment. Depending on application, use face shield, safety goggles or safety glasses. As appropriate, wear dust mask, hearing protectors, gloves, and workshop apron capable of stopping small abrasive or workpiece fragments.** The eye protection must be capable of stopping flying debris generated by various applications. The dust mask or respirator must be capable of filtering particles generated by the particular application. Prolonged exposure to high intensity noise may cause hearing loss.
- j. Keep bystanders a safe distance away from work area. Anyone entering the work area must wear personal protective equipment.** Fragments of workpiece or of a broken accessory may fly away and cause injury beyond immediate area of operation.
- l. Position the cord clear of the spinning accessory.** If you lose control, the cord may be cut or snagged and your hand or arm may be pulled into the spinning accessory.
- m. Never lay the power tool down until the accessory has come to a complete stop.** The spinning accessory may grab the surface and pull the power tool out of your control.
- n. Do not run the power tool while carrying it at your side.** Accidental contact with the spinning accessory could snag your clothing, pulling the accessory into your body.
- o. Regularly clean the power tool's air vents.** The motor's fan will draw the dust inside the housing and excessive accumulation of powdered metal may cause electrical hazards.
- p. Do not operate the power tool near flammable materials.** Sparks could ignite these materials.

- q. **Do not use accessories that require liquid coolants.** Using water or other liquid coolants may result in electrocution or shock.

FURTHER SAFETY INSTRUCTIONS FOR ALL OPERATIONS KICKBACK AND RELATED WARNINGS:

Kickback is a sudden reaction to a pinched or snagged rotating wheel, backing pad, brush or any other accessory. Pinching or snagging causes rapid stalling of the rotating accessory which in turn causes the uncontrolled power tool to be forced in the direction opposite of the accessory's rotation at the point of the binding.

For example, if an abrasive wheel is snagged or pinched by the workpiece, the edge of the wheel that is entering into the pinch point can dig into the surface of the material causing the wheel to climb out or kick out. The wheel may either jump toward or away from the operator, depending on direction of the wheel's movement at the point of pinching. Abrasive wheels may also break under these conditions.

Kickback is the result of power tool misuse and/or incorrect operating procedures or conditions and can be avoided by taking proper precautions as given below.

- a. **Maintain a firm grip with both hands on the power tool and position your body and arms to allow you to resist kickback forces. Always use auxiliary handle, if provided, for maximum control over kickback or torque reaction during start-up.** The operator can control torque reactions or kickback forces, if proper precautions are taken.
- b. **Never place your hand near the rotating accessory.** Accessory may kickback over your hand.
- c. **Do not position your body in the area where power tool will move if kickback occurs.** Kickback will propel the tool in direction opposite to the wheel's movement at the point of snagging.
- d. **Use special care when working corners, sharp edges, etc. Avoid bouncing and snagging the accessory.** Corners, sharp edges or bouncing have a tendency to snag the rotating accessory and cause loss of control or kickback.
- e. **Do not attach a saw chain woodcarving blade, segmented diamond wheel with a peripheral gap greater than 10 mm or toothed saw blade.** Such blades create frequent kickback and loss of control.

ADDITIONAL SAFETY INSTRUCTIONS FOR GRINDING AND CUTTING-OFF OPERATIONS SAFETY WARNINGS SPECIFIC FOR GRINDING AND CUTTING-OFF OPERATIONS:

- a. **Use only wheel types that are specified for your power tool and the specific guard designed for the selected wheel.** Wheels for which the power tool was not designed cannot be adequately guarded and are unsafe.
- b. **The grinding surface of centre depressed wheels must be mounted below the plane of the guard lip.** An improperly mounted wheel that projects through the plane of the guard lip cannot be adequately protected.
- c. **The guard must be securely attached to the power tool and positioned for maximum safety, so the least amount of wheel is exposed towards the operator.** The guard helps to protect the operator from broken wheel fragments, accidental contact with wheel and sparks that could ignite clothing.
- d. **Wheels must be used only for specified applications. For example: do not grind with the side of cut-off wheel.** Abrasive cut-off wheels are intended for peripheral grinding, side forces applied to these

wheels may cause them to shatter.

- e. **Always use undamaged wheel flanges that are of correct size and shape for your selected wheel.** Proper wheel flanges support the wheel thus reducing the possibility of wheel breakage. Flanges for cut-off wheels may be different from grinding wheel flanges.
- f. **Do not use worn down wheels from larger power tools.** A wheel intended for larger power tool is not suitable for the higher speed of a smaller tool and may burst.
- g. **When using dual purpose wheels always use the correct guard for the application being performed.** Failure to use the correct guard may not provide the desired level of guarding, which could lead to serious injury.

ADDITIONAL SAFETY INSTRUCTIONS FOR POLISHING OPERATIONS

SAFETY WARNINGS SPECIFIC FOR POLISHING OPERATIONS:

Do not allow any loose portion of the polishing bonnet or its attachment strings to spin freely. Tuck away or trim any loose attachment strings. Loose and spinning attachment strings can entangle your fingers or snag on the workpiece.

WARNINGS: The guard must always be locked by the lock screw in its detent in the central position. Never change the angle of the guard to any other position.

The end cover on the guard must never be removed. Never attempt to operate the machine without all of its guards in place.

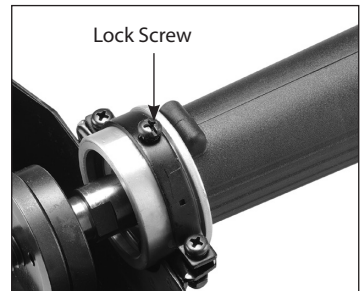

FUNCTIONAL DESCRIPTION

This Straight Grinder is designed for grinding with an abrasive wheel and may also be used for buffing and polishing when fitted with the appropriate accessories.

ELECTRICAL CONNECTION

The network voltage must conform to the voltage indicated on the tool name plate. Under no circumstances should the tool be used when the power supply cable is damaged.

A damaged cable must be replaced immediately by an authorized Customer Service Center. Do not try to repair the damaged cable yourself. The use of damaged power cables can lead to an electric shock.

EXTENSION CABLE

If an extension cable is required, it must have a sufficient cross-section so as to prevent an excessive drop in voltage or overheating. An excessive drop in voltage reduces the output and can lead to failure of the motor. The following table shows you the correct cable diameter as a function of the cable length for this machine. Use only approved extension cables. Never use two extension cables together. Instead, use one long one.

Total Extension	Cord Length (feet)	Cord Size (AWG)
	25	16
	50	12
	100	10
	150	8
	200	6

UNPACKING

Carefully remove the tool and all loose items from the shipping container.

Retain all packing materials until after you have inspected and satisfactorily operated the machine.

CARTON CONTENTS

1. Straight Grinder machine
2. Instruction manual
3. Face spanner wrench

DO NOT OPERATE THIS TOOL UNTIL YOU READ AND UNDERSTAND THE ENTIRE INSTRUCTION MANUAL

TO INSTALL A WHEEL

1. Unplug the machine.
2. Place the Inner Flange, the wheel and then the Flange Nut on the arbor.
3. Using Face Spanner Wrench, tighten the Flange Nut.
4. Removal is the opposite of assembly.

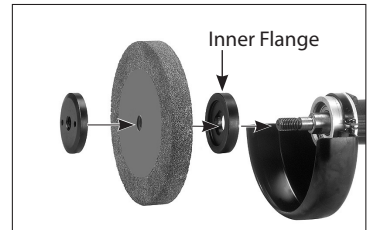

CAUTION: Always store wheels so that they will be protected from damage.

TO INSTALL THE MANDREL ARBOR

The mandrel arbor is used for mounting polishing wheels only.

1. Unplug the machine.
2. Thread the Mandrel Arbor onto the spindle.
3. Using the two open end wrenches, tighten the Mandrel.
4. Install the desired accessory onto the Mandrel.



STARTING AND STOPPING TOOL

Make sure that the power circuit voltage is the same as that shown on the specification plate of the machine and that switch is "OFF" before connecting the tool to the power circuit.

Switching the machine on and off

To switch on:

While holding with the left hand on the front grip and the right hand on the main handle, first press the release button then squeeze the trigger switch to the "on" position. Anticipate and be ready for the start up torque when the machine first starts.

CAUTION: This machine is equipped with a lock off type switch. It is not possible to turn on the trigger switch until the release button is first pressed. Trying to force the switch on without pressing the lock button could damage the switch.

To switch off:

Release the trigger switch.

ADJUSTING THE ROTATION SPEED

The speed of the machine is variable to suit different tasks. It can be adjusted from 1600/min up to 4800/min by using the thumb wheel. turn in the rightward direction to increase the speed and in the leftward direction to decrease the speed.

HOW TO USE THE TOOL

Effective control of this machine requires **two-handed** operation for maximum safety and control. The proper hold is to keep one hand on the main handle and the other hand on the grip. It is vitally important to keep stable footing at all times.

GRINDING OPERATIONS

Once the machine is set up and all safety measures and equipment are in place, begin by turning on the machine.

Begin grinding. It is not necessary to use excessive down force. Allow the machine to work at the pace it was intended.

WARNING: Whenever grinding small workpieces always take measures to clamp the workpieces down.

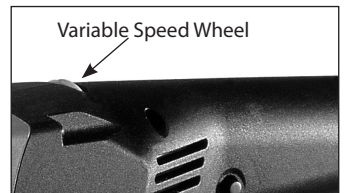
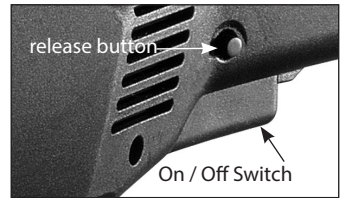

Otherwise they will be flung with great force by the grinding wheel, causing a hazard.

WARNING: Always support the workpiece so that it will be stable during the work process.

MAINTENANCE

Every 50 hours of operation blow compressed air through the motor while running at no load to clean out accumulated dust. (If operating in especially dusty conditions, perform this operation more often.)

KEEP TOOL CLEAN

Periodically blow out all air passages with dry compressed air. All plastic parts should be cleaned with a soft damp cloth. NEVER use solvents to clean plastic parts. They could possibly dissolve or otherwise damage the material.

Wear safety glasses while using compressed air.

THE CARBON BRUSHES

The carbon brushes are a normal wearing part and must be replaced when they reach their wear limit.

NOTE: Checking and replacing the carbon brushes should be entrusted to a qualified service center.

The carbon brushes furnished will last approximately 50 hours of running time or 10,000 on/off cycles. Replace both carbon brushes when either has less than 1/4" length of carbon remaining. To inspect or replace brushes, first unplug the machine and lay it on its side. To inspect or replace brushes, first unplug the machine. Carefully remove the 4 screws to separate the rear handle halves and then remove the 4 screws which connect the handle to the motor housing. Lift away the left-hand handle half first. There will still be wires connected to the rear handle, so take care that these are not stressed. Simply hold the rear handle off to one side. Next remove the two screws holding on the Electronics Unit to allow access to the Brush screws. Hold the Electronics Unit off to one side and avoid stressing the wires. Rotate the spiral spring to relieve the tension on the brush and slide it out of the holder.

Unscrew the two screws which hold the brush leads and remove the Carbon Brushes.

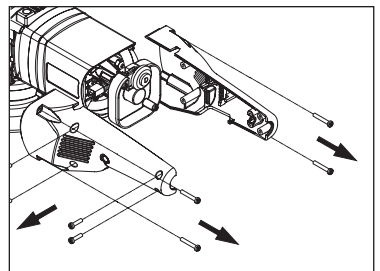

NOTE: When putting the Carbon Brushes back into the Carbon Brush Holders it is essential that both flanges go back inside the holder.

NOTE: To reinstall the same brushes, first make sure the brushes go back in the way they came out. Otherwise a break-in period will occur that will reduce motor performance and increase brush wear.

Replacing is the reverse of removal. When Replacing all covers, take great care that all wires are in place and not in a position to be pinched when they are retightened. It is recommended that, at least once a year, you take the tool to an Authorized Service Center for a thorough cleaning and lubrication.

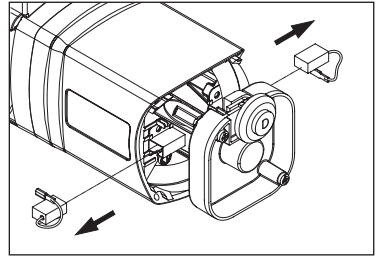

If the replacement of the power supply cord is necessary, this has to be done by the manufacturer or their agent in order to avoid a safety hazard.

WARNING: All repairs must be entrusted to an authorized service center. Incorrectly performed repairs could lead to injury or death.

WIRING

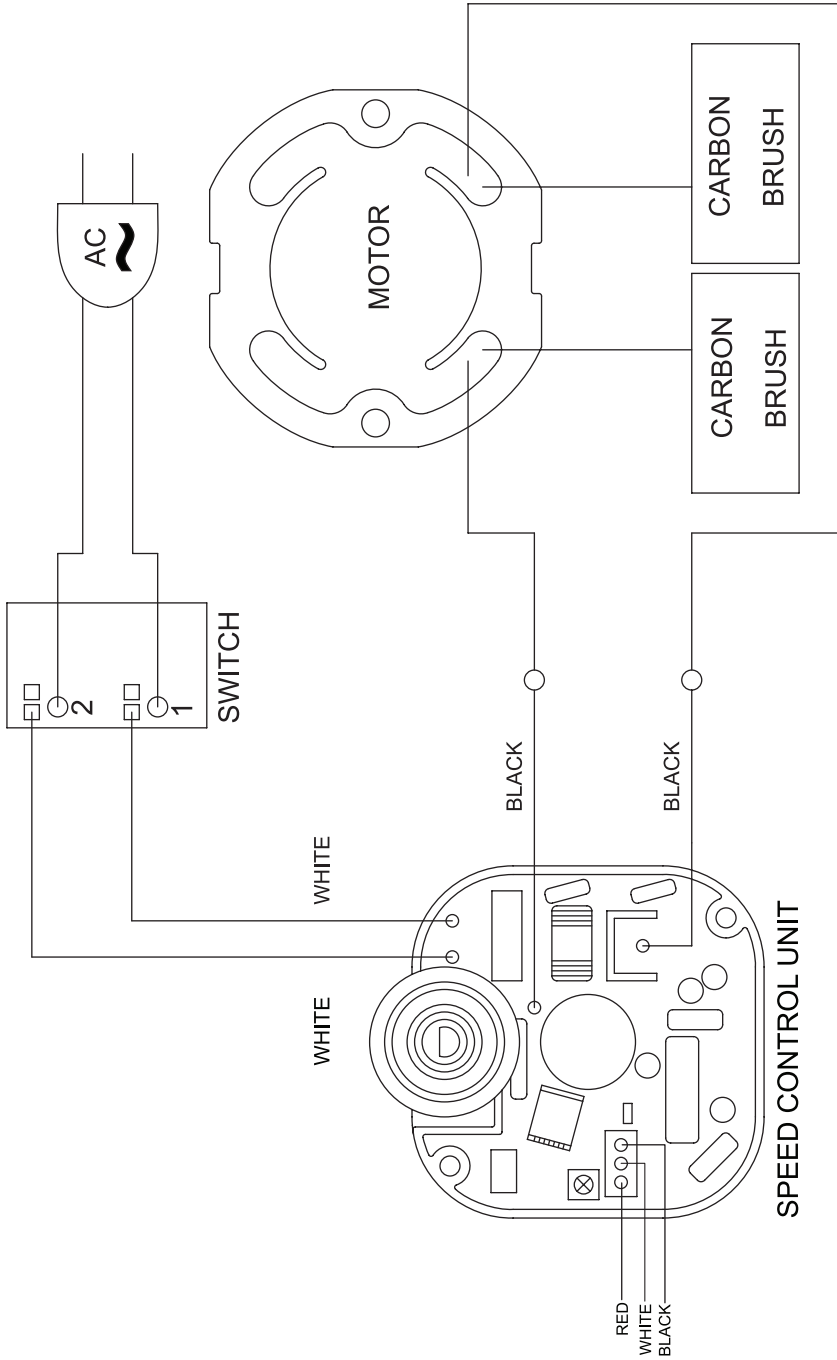

EXPLODED VIEW

NO.01~51 Version 2024.03.04.D.122

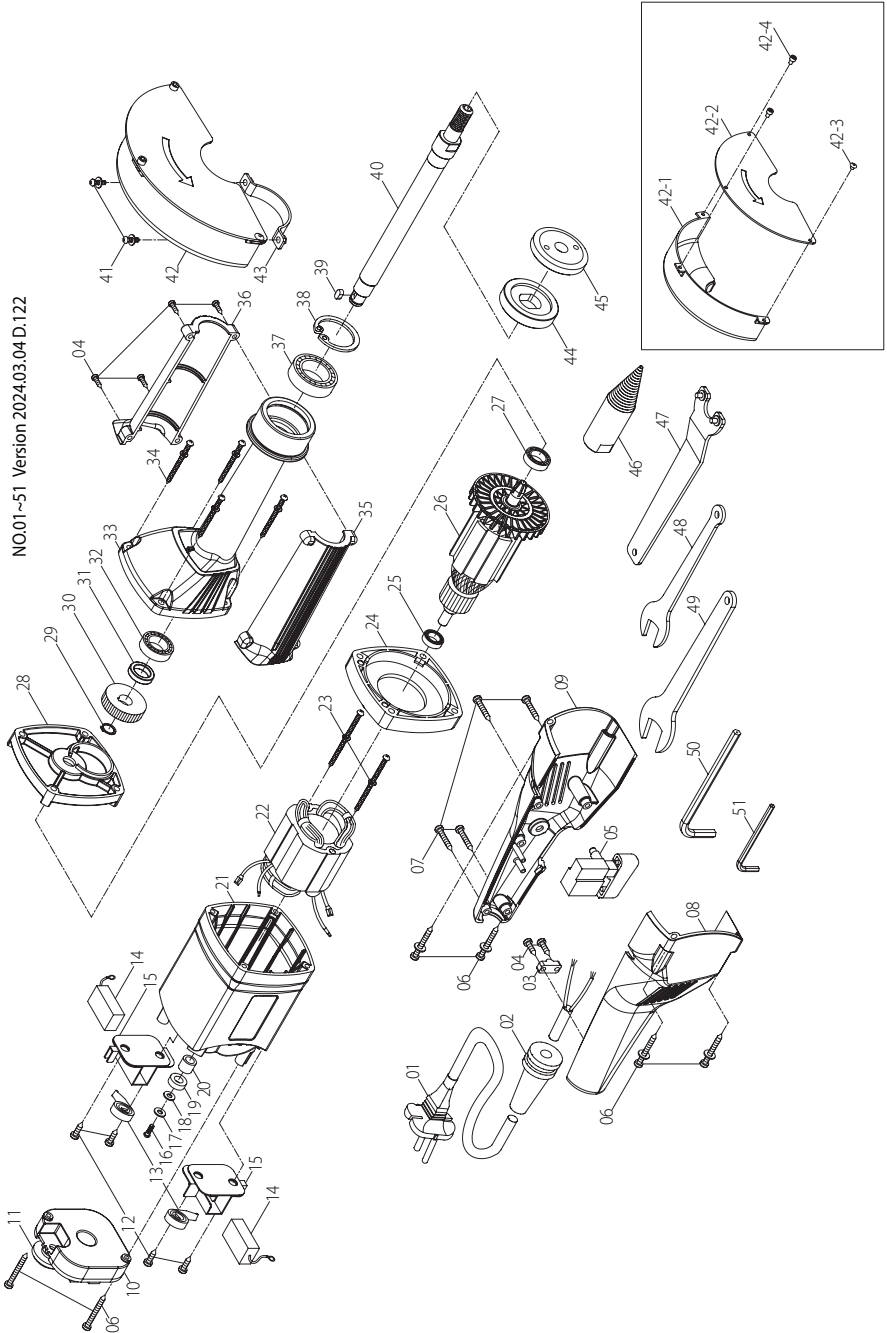

PARTS LIST

NO.	Parts Name	Q'TY
1	POWER SUPPLY CABLE	1
2	CORD ARMOR	1
3	CABLE CLIP	1
4	PANHEAD TAPPING SCREW (M4x14)	6
5	SWITCH (110V/220V)	1
6	PANHEAD TAPPING SCREW (M4x30)	6
7	PANHEAD TAPPING SCREW (M4x16)	4
8	HANDLE HALF-RIGHT	1
9	HANDLE HALF-LEFT	1
10	ELECTRONICS UNIT (110V/220V)	1
11	THUMB WHEEL	1
12	PANHEAD TAPPING SCREW (M4x10)	4
13	BRUSH SPRING (0.35x3x3.5T)	2
14	CARBON BRUSH (7x11x17)	2
15	BRUSH HOLDER (7x11)	2
16	PANHEAD MACHINE SCREW (M4x10xP0.7)	1
17	FLAT WASHER (Ø4xØ10x1)	1
18	RUBBER WASHER (Ø4xØ11x1)	1
19	PICKUP MAGNET (Ø8xØ15x5)	1
20	SPACER (Ø8xØ12x10.5)	1
21	MOTOR HOUSING	1
22	STATOR (110V/220V-73x42x45)	1
23	PANHEAD TAPPING SCREW (M5x60)	2
24	FAN SHROUD	1
25	BALL BEARING (608)	1
26	ARMATURE (110V/220V-73x42x45)	1
27	BALL BEARING (6000)	1
28	GEAR PLATE	1
29	EXTERNAL CIRCLIP (S-12)	1
30	OUTPUT GEAR (M1.0x33T)	1
31	SHAFT RACE (Ø15.1xØ22x5)	1
32	BALL BEARING (6002)	1
33	GEAR HOUSING	1
34	PANHEAD TAPPING SCREW (M5x50)	4
35	RIGHT CASE SLEEVE COVER	1
36	LEFT CASE SLEEVE COVER	1
37	BALL BEARING (6203)	1
38	INTERNAL CIRCLIP (R-40)	1
39	PARALLEL KEY (4x4x8)	1
40	SPINDLE (M14xP2.0-255MM)	1
41	PANHEAD MACHINE SCREW (M5x10xP0.8)	2
42	GUARD	1
43	GUARD BRACKET	1
44	INNER FLANGE (Ø20)	1
45	FLANGE NUT (M12)	1
46	MANDREL ARBOR (M12)	1
47	LOCK NUT WRENCH (30MM)	1
48	WRENCH (M17)	1
49	WRENCH (M22)	1
50	HEX KEY (M5)	1
51	HEX KEY (M3)	1

