

# AGP<sup>®</sup>

## Drill Motor

DM52D



### Instruction Manual

CE CB 



## TECHNICAL DATA

Model		DM52D
Power Input		1800 W
Voltage		110-120 V~ 50-60 Hz, or 220-240 V~ 50-60 Hz (See machine nameplate)
No Load /Full Load min <sup>-1</sup>	Speed 1	1800 / 1080
	Speed 2	3600 / 2160
Percussion Frequency	Speed 1	29,000 bpm
	Speed 2	56,000 bpm
Arbor Thread		1-1/4-7 UNC male x 1/2" BSP female
Capacity-Dry		182 mm (7-1/4")
Dimensions (mm)		505 x 105 x 210 mm
Neck Diameter		60 mm
Net Weight		4.9 kg (10.8 lb)



1. Lock Button
2. Trigger Switch
3. Tubular Spirit Level
4. Release Button
5. Lock Screw (Side Handle)
6. Side Handle
7. Spindle
8. Percussion Selector
9. Vacuum Adaptor Head
10. Gear Selector
11. Motor
12. Main Handle
13. Power Supply Cable
14. Hammer Symbol (Percussion On)
15. No Hammer Symbol (Percussion Off)

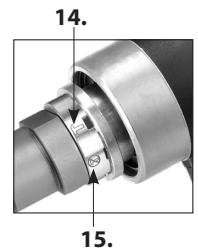

# GENERAL SAFETY RULES



**WARNING! Read all safety warnings and all instructions.** Failure to follow the warnings and instructions may result in electric shock, fire and/or serious injury.

**Save all warnings and instructions for future reference.**

The term “power tool” in the warnings refers to your mains-operated (corded) power tool or battery-operated (cordless) power tool.

## 1. WORK AREA SAFETY

- a. **Keep work area clean and well lit.** Cluttered and dark areas invite accidents.
- b. **Do not operate power tools in explosive atmospheres, such as in the presence of flammable liquids, gases or dust.** Power tools create sparks which may ignite the dust or fumes.
- c. **Keep children and bystanders away while operating a power tool.** Distractions can cause you to lose control.
- d. **Never leave the electric power tool unattended.** Only leave the machine when the tool in use has come to a complete standstill.

## 2. ELECTRICAL SAFETY

- a. **Power tool plugs must match the outlet. Never modify the plug in any way. Do not use any adapter plugs with earthed (grounded) power tools.** Unmodified plugs and matching outlets will reduce risk of electric shock.
- b. **Avoid body contact with earthed or grounded surfaces, such as pipes, radiators, ranges and refrigerators.** There is an increased risk of electric shock if your body is earthed or grounded.
- c. **Do not expose power tools to rain or wet conditions.** Water entering a power tool will increase the risk of electric shock.
- d. **Do not abuse the cord. Never use the cord for carrying, pulling or unplugging the power tool. Keep cord away from heat, oil, sharp edges or moving parts.** Damaged or entangled cords increase the risk of electric shock.
- e. **When operating a power tool outdoors, use an extension cord suitable for outdoor use.** Use of a cord suitable for outdoor use reduces the risk of electric shock.
- f. **If operating a power tool in a damp location is unavoidable, use a residual current device (RCD) protected supply.** Use of an RCD reduces the risk of electric shock.

## 3. PERSONAL SAFETY

- a. **Stay alert, watch what you are doing and use common sense when operating a power tool. Do not use a power tool while you are tired or under the influence of drugs, alcohol or medication.** A moment of inattention while operating power tools may result in serious personal injury.
- b. **Use personal protective equipment. Always wear eye protection.** Protective equipment such as dust mask, non-skid safety shoes, hard hat, or hearing protection used for appropriate conditions will reduce personal injuries.

- c. **Prevent unintentional starting. Ensure the switch is in the off-position before connecting to power source and/or battery pack, picking up or carrying the tool.** Carrying power tools with your finger on the switch or energising power tools that have the switch on invites accidents.
- d. **Remove any adjusting key or wrench before turning the power tool on.** A wrench or a key left attached to a rotating part of the power tool may result in personal injury.
- e. **Do not overreach. Keep proper footing and balance at all times.** This enables better control of the power tool in unexpected situations.
- f. **Dress properly. Do not wear loose clothing or jewellery. Keep your hair and clothing away from moving parts.** Loose clothes, jewellery or long hair can be caught in moving parts.
- g. **If devices are provided for the connection of dust extraction and collection facilities, ensure these are connected and properly used.** Use of dust collection can reduce dust-related hazards.
- h. **Do not let familiarity gained from frequent use of tools allow you to become complacent and ignore, tool safety principles.** A careless action can cause severe injury within a fraction of a second.

#### 4. POWER TOOL USE AND CARE

- a. **Do not force the power tool. Use the correct power tool for your application.** The correct power tool will do the job better and safer at the rate for which it was designed.
- b. **Do not use the power tool if the switch does not turn it on and off.** Any power tool that cannot be controlled with the switch is dangerous and must be repaired.
- c. **Disconnect the plug from the power source and/or battery pack from the power tool before making any adjustments, changing accessories, or storing power tools.** Such preventive safety measures reduce the risk of starting the power tool accidentally.
- d. **Store idle power tools out of the reach of children and do not allow persons unfamiliar with the power tool or these instructions to operate the power tool.** Power tools are dangerous in the hands of untrained users.
- e. **Maintain power tools. Check for misalignment or binding of moving parts, breakage of parts and any other condition that may affect the power tool's operation. If damaged, have the power tool repaired before use.** Many accidents are caused by poorly maintained power tools.
- f. **Keep cutting tools sharp and clean.** Properly maintained cutting tools with sharp cutting edges are less likely to bind and are easier to control.
- g. **Use the power tool, accessories and tool bits etc. in accordance with these instructions taking into account the working conditions and the work to be performed.** Use of the power tool for operations different from those intended could result in a hazardous situation.
- h. **Keep handles dry, clean and free of oil and grease.** Slippery handles do not allow for safe handling and control of the tool in unexpected situations.

#### 5. SERVICE

- a. **Have your power tool serviced by a qualified repair person using only identical replacement parts.** This will ensure that the safety of the power tool is maintained.
- b. **Only use original parts for repair and maintenance.** The use of incompatible accessories or spare parts can result in electric shocks or other injuries.

## Symbols used in this manual

V.....volts

A.....amperes

Hz.....hertz

W.....watt

~.....alternating current

n .....rated speed

min<sup>-1</sup>.....revolutions or reciprocation  
per minute



.....warning of general danger



.....class II tool



.....read these instructions



.....always wear eye protection



.....always wear a dust mask.



.....always wear hearing protection



.....wear safety-approved hard hat



do not dispose of electric tools,  
accessories and packaging together  
with household waste material

## DRILL SAFETY WARNINGS

1. **Wear ear protectors when impact drilling.** Exposure to noise can cause hearing loss.
2. **Use auxiliary handle.** Loss of control can cause personal injury.
3. **Hold power tool by insulated gripping surfaces, when performing an operation where the cutting accessory may contact hidden wiring or its own cord.** Cutting accessory contacting a "live" wire may make exposed metal parts of the power tool "live" and could give the operator an electric shock.
4. **Check the ground (earth) connection of the electrical plug.**
5. **Block off the working area and place warning signs on both sides of the wall when drilling through from one side to the other.**

## INTRODUCTION

The machine is equipped with a tubular spirit level to aid in aligning when drilling horizontally. By positioning the machine so that the bubble is in the center of the window one can drill a straight hole.

This machine is for the intended purpose of diamond core drilling of concrete, masonry, stone and similar materials. It may also be mounted on a rig (drilling stand).

All other uses which are not for the intended purpose are prohibited.

It is equipped with a two speed gearbox.

All models are equipped with a mechanical safety clutch.

All models have electronics for soft start, overload protection, thermal protection.

## ELECTRICAL CONNECTION

The network voltage must conform to the voltage indicated on the tool name plate.

Under no circumstances should the tool be used when the power supply cable is damaged. A damaged cable must be replaced immediately by an authorized Customer Service Center. Do not try to repair the damaged cable yourself. The use of damaged power cables can lead to an electric shock.

## ASSEMBLY

Mount the handle clamp of the side handle onto the gearbox neck. Position the side handle perpendicular to the main handle. Use the lock screw to tighten the clamp.

## LIST OF CONTENTS

- Diamond core drilling machine.
- Side handle assembly
- Vacuum adaptor

## OPERATING INSTRUCTIONS

### Mounting the core bit

**CAUTION: Ensure that the threads of the spindle and the core bit match. Attempting to mount mismatched threads will result in damage to both threads.**

Ensure both the core bit and the machine spindle are clean. Any debris could cause excessive run-out of the mounted core bit. Excessive run-out can cause premature failure of the core bit and/or a safety hazard. Tighten the bit to the spindle using two wrenches.

### Choosing the correct core bit for the job

Ensure that the bit you are using is suitable for the material you are drilling. There are two main types of diamond core bit:

Dry bits and wet bits. This machine should only be used with dry bits.

## DRY DRILLING

Dry drilling is a different process from wet drilling.

When dry drilling, you must not push too hard. Allow the tool to work at its own pace.

Dry drilling is normally done in softer materials. Note that in very hard materials it may not be possible to drill dry.

## SELECTING SPEEDS





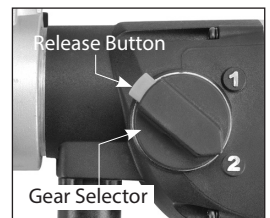

There are 2 speed ranges to suit the bit size and work piece hardness.

**CAUTION: Never attempt to change gears on a running machine! Only adjust when the machine is at rest.**

Select the desired gear range by pressing the release button and then turning the gear selector either clockwise or counterclockwise into the desired gear. It will usually be necessary to turn the spindle by hand a little to get it to shift all the way.



## DM52D-DRY DRILLING RECOMMENDED GEARS (soft materials)

BitØ \ Gear	20mm	40mm	102mm	162mm	182mm
Gear 2					
Gear 1					



Impossible /  
Not recommended



Possible



Ideal

## PERCUSSION SELECTOR

The percussion function can be turned on and off.

To select, push on the collar against the spring tension to disengage the teeth from the slots and turn to either the "Hammer" symbol for soft percussion or the "No Hammer" symbol to turn the percussion OFF.

The main purpose of soft percussion function on this machine is to keep the diamond segments sharp. If the bit is staying sharp without it, the percussion function may be turned off. If the bit glazes easily, it should be turned on.



## THE SWITCH

The machine has a lockable trigger switch. Squeeze the trigger to start the machine. To lock the switch on, press the lock button while holding the trigger switch on. To release, squeeze the trigger and release.

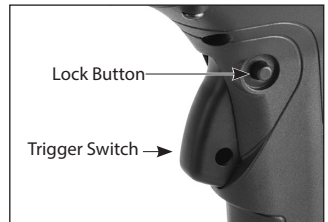

**WARNING: Never lock the switch on when drilling hand-held. Only lock the switch on when mounted to a rig.**

## OVERLOAD PROTECTION AND OVERHEAT PROTECTION

### Overload:

If the excessive load is sustained too long, the motor will shut down completely. In this case, the motor must be restarted by turning OFF and then back ON the switch.

### Overheat Thermal Protection:

If the temperature of the motor gets too high, the thermal protection will shut the motor down. When this happens, do not immediately put a load on the motor after restarting. Always run the machine at no load for a few minutes to return to a normal operating temperature before continuing.

**CAUTION: The motor will be damaged if it is repeatedly overloaded or overheated. Always cool the motor by running at no load for a few minutes whenever it stops from either overheat or overload.**

## SAFETY CLUTCH

This machine is equipped with a mechanical clutch to protect the operator and machine from excessive torque forces. After the clutch slips many times, it will become worn and slip at lower and lower torque levels. When this happens, it must be serviced by an authorized service provider. The recommended torque of the clutch nut is 21 Nm.

## DIAMOND CORE DRILLING

1. Very gently begin the cut. If holding by hand, start the cut by approaching at an angle of about 30 degrees to the cutting surface. (A large piece of wood with a large V notch cut in it will help prevent the bit from wandering at the beginning.) Once about a third of the arc is cut, straighten the bit to the correct perpendicular angle while keeping enough feed pressure on the bit to prevent it from wandering.
2. Once in the cut, use steady feed pressure .
3. When breaking through, hold the machine tightly and reduce feed pressure .

**WARNING: Always keep your face away from the machine.**

The diamond impregnated segments in diamond core bit operate on a principle of controlled erosion. The bond matrix holding the diamonds is continually worn away by abrasion with the work piece, exposing the harder diamonds to stand proud from the bond matrix.

With not enough erosion of the bond matrix (the diamonds not exposed) and the bit becomes dull.

This is called glazing. If the bit seems to refuse to cut anymore, it is glazed.

**See below: "SHARPENING A GLAZED BIT "**

Never use a sharp motion or the bit will be damaged. Conversely, don't feed too gently or the diamond segments will become glazed. Keep the bit steadily working.

If holding by hand, take great care to keep the bit aligned to the hole. If the bit is crooked, it will easily bind.

**CAUTION: If the bit gets stuck, do not try to rock it loose by turning the switch on and off. That is hazardous and could damage the motor. Rather, unplug the machine and use a wrench on the bit mounting to work it loose.**

**CAUTION: Drilling operations are very stressful to the motor and at the end of the cut, the motor temperature will be very hot, always run the motor at no load for a few minutes until the temperature returns to a normal range before shutting off.**

Then turn off the switch and allow the coasting bit to stop before setting it down.

## RESHARPENING A GLAZED BIT

If the bit becomes glazed, sharpen and true it up is by dressing with an appropriate alumina oxide or silicon carbide dressing stone. Simply drill into the stone as many times as necessary to restore its cutting performance.

## VIBRATION TROUBLESHOOTING

If vibration occurs and it is not caused by embedded steel, stop drilling to find the cause and remedy.

**CAUTION: Do not operate with vibration or there will be serious hazard and the diamond core bit will surely be destroyed.**



## **Vibration is usually caused by:**

1. A bit with too much runout  
**SOLUTION:** Replace bit.
2. A bit with diamond segments broken off  
**SOLUTION:** Repair or replace bit.

## **MAINTENANCE**

Every 50 hours of operation blow compressed air through the motor while running at no load to clean out accumulated dust.

Always check for a damaged power supply cable, check for loose fasteners and always keep alert for unusual noises and vibration when operating.

**WARNING: Never operate a damaged machine. Always tag a damaged machine and take it out of service until repairs can be made.**

Maintenance which should be performed by an authorized service center, include the following:

- Replace the carbon brushes as needed
- Change the gearbox grease about every 100 hours of operation
- Replace the clutch discs and spring as needed.

## **THE CARBON BRUSHES**

The carbon brushes are a normal wearing part and must be replaced when they reach their wear limit. This machine is equipped with auto-stop carbon brushes. If the machine comes to a stop unexpectedly, the brushes should be checked. The auto-stop brush design protects the motor by stopping the machine before the carbon brushes are completely worn out.

**Caution: Always replace the brushes as a pair.**

### **To replace:**

1. Remove the 14 screws to open up the handle halves. Carefully move the parts to one side, taking care not to strain the wiring.
2. Using pliers rotate the brush spring out of the way and slide the old carbon brush out of the brush holder.
3. Unscrew the screw to remove the brush lead. The old carbon brush may now be lifted away.
4. Install a new brush. Installation is the reverse of removal.
5. Replacement is the reverse of removal. Take care not to pinch any wires when reassembling.

**If the replacement of the power supply cord is necessary, this has to be done by the manufacturer or their agent in order to avoid a safety hazard.**

**WARNING: All repairs must be entrusted to an authorized service center.** Incorrectly performed repairs could lead to injury or death.

Do not throw electric power tools into the household waste!

In accordance with the European Directive 2002/96/EG on Waste Electrical and Electronic Equipment and transposition into national law, used electric power tools must be collected separately and recycled in an environmentally friendly manner.

# Exploded View

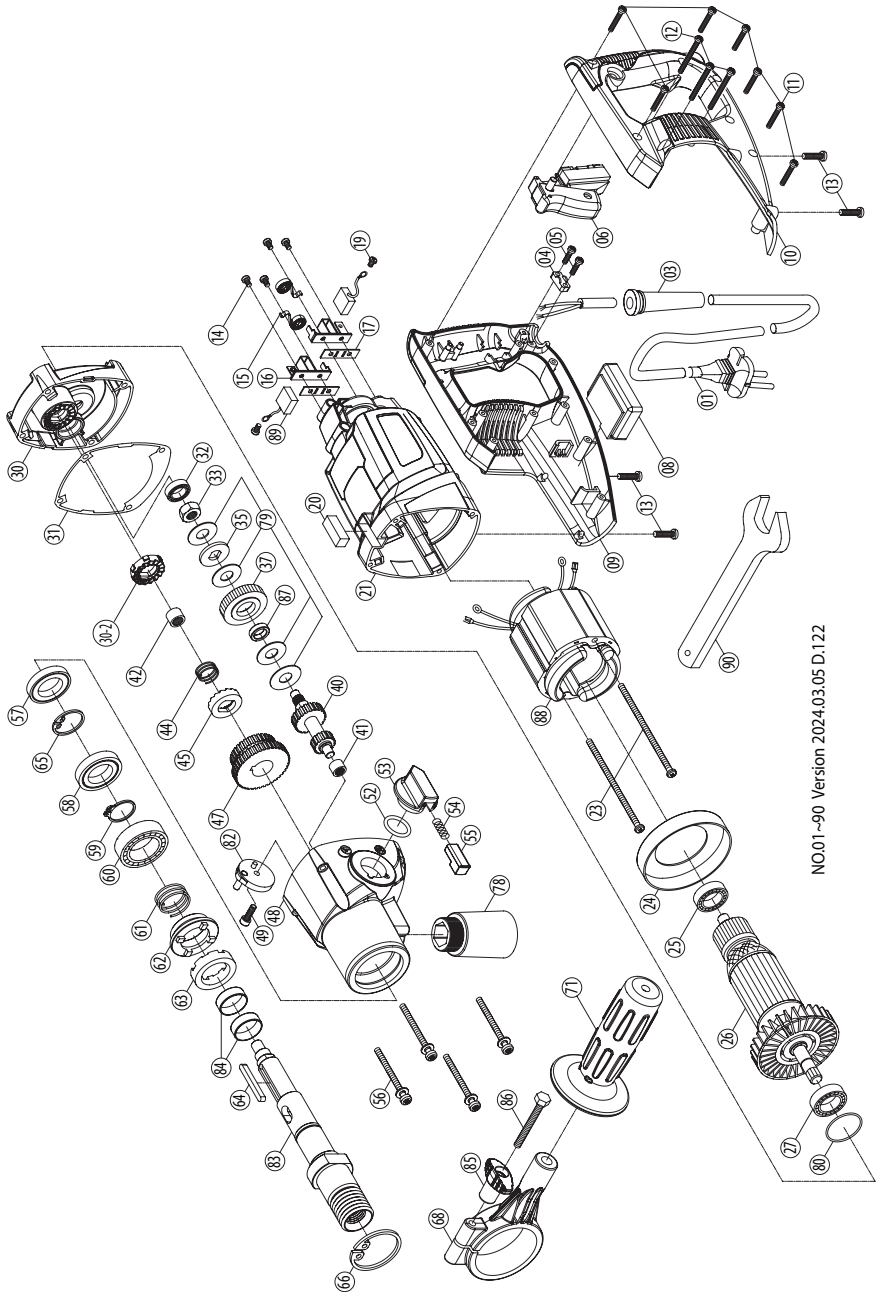

NO.01~90 Version 2024.03.05 D.122

## Parts List

NO.	Parts Name	Q'TY	NO.	Parts Name	Q'TY
1	POWER SUPPLY CABLE (UK-1.5x2Cx3M-H07RNF)	1	44	SPRING (Ø1.1xØ17xØ19.2x3.5Tx15L)	1
1	POWER SUPPLY CABLE (VDE-1.0x2Cx3M-H07RNF)	1	45	CAM PLATE (B)	1
3	CORD ARMOR	1	47	SLIDER GEAR-AB (DP20x32TxM1.25x41T)	1
4	CABLE CLIP	1	48	GEAR HOUSING	1
5	PANHEAD TAPPING SCREW (M4x14)	2	49	SOCKET CAP SCREW (M5x12xP0.8)	1
6	SWITCH (110V&220V)	1	52	O-RING (Ø20x3)	1
8	ELECTRONICS UNIT (110V/220V)	1	53	GEAR SELECTOR	1
9	D-HANDLE HALF-RIGHT	1	54	SPRING (Ø0.6xØ3.8xØ5x11Tx35L)	1
10	D-HANDLE HALF-LEFT	1	55	RELEASE PIN	1
11	PANHEAD TAPPING SCREW (M4x25)	7	56	TORX PANHEAD TAPPING SCREW (M5x60)	4
12	PANHEAD TAPPING SCREW (M4x35)	3	57	OIL SEAL (Ø27xØ42x7)	1
13	TORX PANHEAD TAPPING SCREW (M5x20)	4	58	OIL SEAL (Ø27xØ45x8)	1
14	PANHEAD TAPPING SCREW (M4x8)	4	59	INTERNAL CIRCLIP (IS28)	1
15	BRUSH SPRING (0.4x4x3T)	2	60	BALL BEARING (60/28)	1
16	CARBON BRUSH HOLDER (7x17)	2	61	SPRING (Ø1.2xØ28.2xØ30.6x5Tx40L)	1
17	INSULATION PLATE (10x38x1)	2	62	IMPACT SELECTOR COLLAR	1
19	PANHEAD MACHINE SCREW (M4x6xP0.7)	2	63	ENGAGEMENT COLLAR	1
20	SPIRIT LEVEL (10x10x29)	1	64	PARALLEL KEY (5x5x45)	1
21	MOTOR HOUSING	1	65	INTERNAL CIRCLIP (R-42)	1
23	PANHEAD TAPPING SCREW (3/16"x3")	2	66	INTERNAL CIRCLIP (R-52)	1
24	FAN SHROUD	1	68	HANDLE CLAMP	1
25	BALL BEARING (6200)	1	71	FRONT HANDLE (M12xP1.75)	1
26	ARMATURE (110V/220V-81x45.8x60)	1	78	UNIVERSAL PORT	1
27	BALL BEARING (6201)	1	79	CLUTCH DISC SET	1
30	GEAR PLATE	1	80	O-RING (Ø32x1.5)	1
30-2	CAM PLATE (A)	1	82	SELECTOR DISC	1
31	GASKET	1	83	SPINDLE (1 1/4"-7x1/2"BSP-224.5MM)	1
32	BALL BEARING (608)	1	84	STAINLESS BUSHING	2
33	CLUTCH NUT (M10xP1.25x8.1T)	1	85	HAND KNOB	1
35	PRESSURE DISC (Ø12.1xØ28x2.65)	1	86	HEX BOLT (M6x60xP1.0)	1
37	INPUT GEAR (M1.0x34T)	1	87	BUSHING (Ø12xØ18x4.2)	1
40	INPUT SHAFT (DP20x21TxM1.25x14T)	1	88	STATOR (110V/220V-81x45.6x60)	1
41	NEEDLE BEARING (HK 0810)	1	89	CARBON BRUSH (7x17x19)(110V/220V)	2
42	NEEDLE BEARING (HK 1010)	1	90	WRENCH (M32)	1

# WIRING

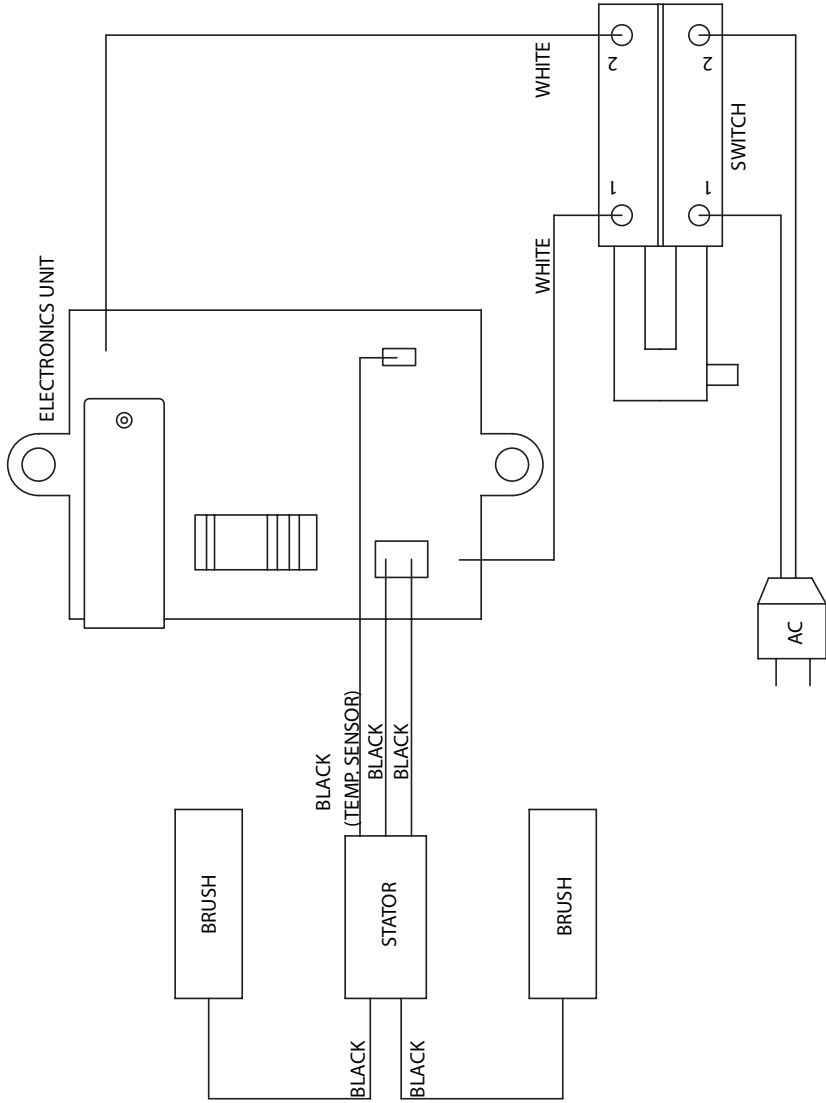

## Noise/vibration information

Measured in accordance with EN 60745-2-1

**Note: Vibration tests were performed with 80 mm drill bit according to instructions under hand-held mode.**

**Model no. : DM52D**

**Noise level:** Sound pressure level( $L_{pA}$ ): 94.0 dB(A)    Sound power level( $L_{wA}$ ): 105.0 dB(A)     $K = 3.0$  dB

**Vibration level:**  $a_{h,10}$ : 17,3 m/s<sup>2</sup>     $K = 1,5$  m/s<sup>2</sup> (Impact drilling into concrete)

**Vibration level:**  $a_{h,DD}$ : 10,1 m/s<sup>2</sup>     $K = 1,5$  m/s<sup>2</sup> (Drilling into concrete)

The vibration emission level has been measured in accordance with a standardised test given in EN 60745; it may be used to compare one tool with another and as a preliminary assessment of exposure to vibration when using the tool for the applications mentioned

- using the tool for different applications, or with different or poorly maintained accessories, may significantly increase the exposure level

- the times when the tool is switched off or when it is running but not actually doing the job, may significantly reduce the exposure level

protect yourself against the effects of vibration by maintaining the tool and its accessories, keeping your hands warm, and organizing your work patterns

## CE Declaration of Conformity

•We declare under our sole responsibility that this product is in conformity with the following standards or standardized documents: EN 60745-1: 2009 + A11: 2010 & EN 60745-2-1: 2010 EN 61000, EN 55014 in accordance with the regulations 2014/30/EU, 2006/42/EC, 2011/65/EU

•Technical file at: LEE YEONG INDUSTRIAL CO., LTD., NO.2, KEJIA RD., DOULIU CITY, YUNLIN COUNTY 64057, TAIWAN

You-Chun, Liu  
Operation & Engineering

*You chun Liu*

Chih-Hao, Lai  
Approval Manager

*chih hao lai*

LEE YEONG INDUSTRIAL CO., LTD.,  
NO.2, KEJIA RD., DOULIU CITY, YUNLIN COUNTY 64057, TAIWAN    12.30.2016

**LEE YEONG INDUSTRIAL CO., LTD.**

NO.2, KEJIA RD., DOULIU CITY,  
YUNLIN COUNTY 64057, TAIWAN

TEL: 886-5-5518689 (REP)

Fax: 886-5-5518635





