

# AGP®

## Drill Motor

DM9 / DM10 / DM12 / DM14



**4 Speed Model**  
DM14



**3 Speed Models**  
DM9, DM10, DM12

## Instruction Manual

CE CB



## TECHNICAL DATA

Model	DM14	DM12	DM10	DM9
Voltage / Power	220-240 V~ 50-60 Hz / 16 A: 3500 W or 110-120 V~ 50-60 Hz / 25 A: 2800 W (see nameplate)			
No Load Speeds min <sup>-1</sup>	385 / 530 / 975 / 1340	350 / 600 / 1000	450 / 810 / 1300	550 / 1000 / 1600
Rated Load Speeds min <sup>-1</sup>	225 / 300 / 565 / 780	220 / 370 / 620	270 / 480 / 780	345 / 630 / 1000
Drilling Capacity	Ø400 mm (16")	Ø350 mm (14")	Ø300 mm (12")	Ø250 mm (10")
Dimensions	550 x 155 x 210 mm			
Gear Oil Type	80W-90			
Gear Oil Capacity	625 ml			
Spindle Thread	1-1/4" UNC male, 1/2" BSP female			
Protection Class	Class 1 With RCD			
Weight	13.5 kg	12.3 kg		

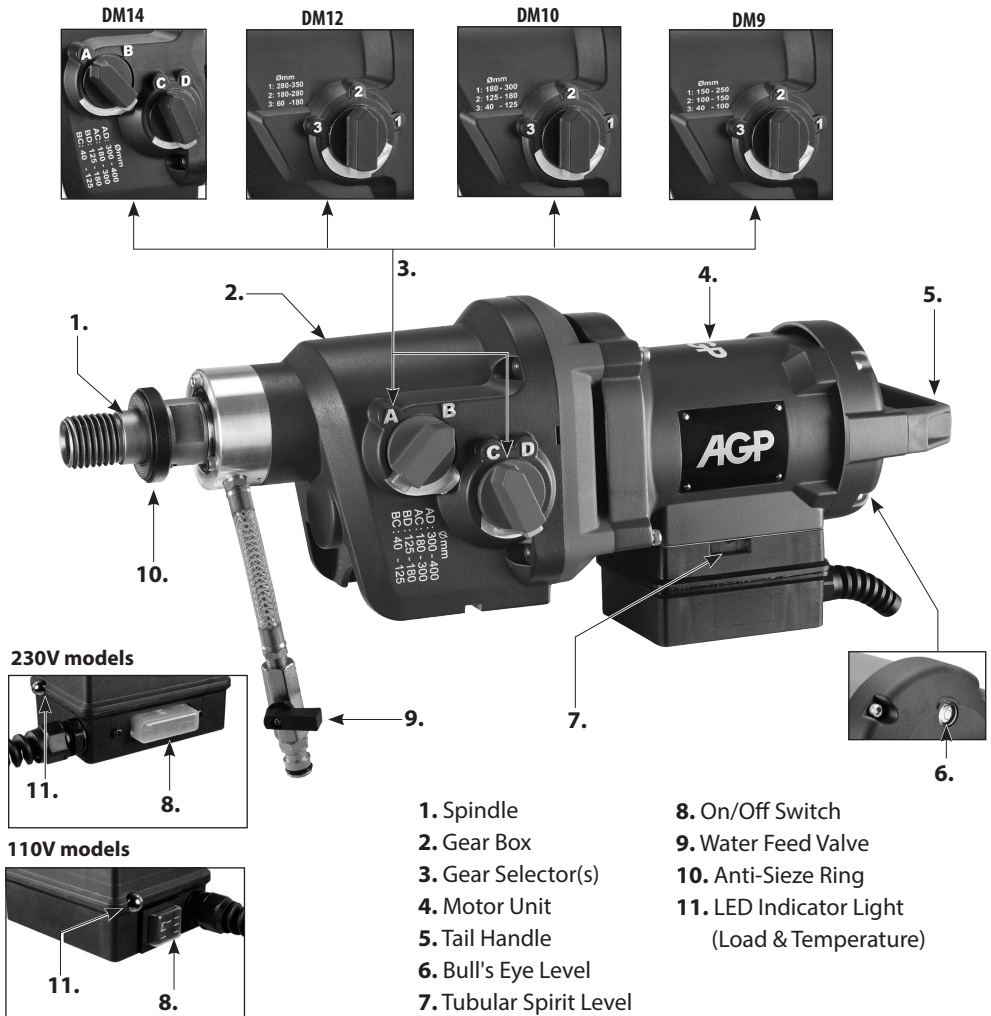

# GENERAL SAFETY RULES



**WARNING! Read all safety warnings and all instructions.** Failure to follow the warnings and instructions may result in electric shock, fire and/or serious injury.

**Save all warnings and instructions for future reference.**

The term “power tool” in the warnings refers to your mains-operated (corded) power tool or battery-operated (cordless) power tool.

## 1. WORK AREA SAFETY

- a. **Keep work area clean and well lit.** Cluttered and dark areas invite accidents.
- b. **Do not operate power tools in explosive atmospheres, such as in the presence of flammable liquids, gases or dust.** Power tools create sparks which may ignite the dust or fumes.
- c. **Keep children and bystanders away while operating a power tool.** Distractions can cause you to lose control.
- d. **Never leave the electric power tool unattended.** Only leave the machine when the tool in use has come to a complete standstill.

## 2. ELECTRICAL SAFETY

- a. **Power tool plugs must match the outlet. Never modify the plug in any way. Do not use any adapter plugs with earthed (grounded) power tools.** Unmodified plugs and matching outlets will reduce risk of electric shock.
- b. **Avoid body contact with earthed or grounded surfaces, such as pipes, radiators, ranges and refrigerators.** There is an increased risk of electric shock if your body is earthed or grounded.
- c. **Do not expose power tools to rain or wet conditions.** Water entering a power tool will increase the risk of electric shock.
- d. **Do not abuse the cord. Never use the cord for carrying, pulling or unplugging the power tool. Keep cord away from heat, oil, sharp edges or moving parts.** Damaged or entangled cords increase the risk of electric shock.
- e. **When operating a power tool outdoors, use an extension cord suitable for outdoor use.** Use of a cord suitable for outdoor use reduces the risk of electric shock.
- f. **If operating a power tool in a damp location is unavoidable, use a residual current device (RCD) protected supply.** Use of an RCD reduces the risk of electric shock.

## 3. PERSONAL SAFETY

- a. **Stay alert, watch what you are doing and use common sense when operating a power tool. Do not use a power tool while you are tired or under the influence of drugs, alcohol or medication.** A moment of inattention while operating power tools may result in serious personal injury.
- b. **Use personal protective equipment. Always wear eye protection.** Protective equipment such as dust mask, non-skid safety shoes, hard hat, or hearing protection used for appropriate conditions will reduce personal injuries.

- c. **Prevent unintentional starting. Ensure the switch is in the off-position before connecting to power source and/or battery pack, picking up or carrying the tool.** Carrying power tools with your finger on the switch or energising power tools that have the switch on invites accidents.
- d. **Remove any adjusting key or wrench before turning the power tool on.** A wrench or a key left attached to a rotating part of the power tool may result in personal injury.
- e. **Do not overreach. Keep proper footing and balance at all times.** This enables better control of the power tool in unexpected situations.
- f. **Dress properly. Do not wear loose clothing or jewellery. Keep your hair and clothing away from moving parts.** Loose clothes, jewellery or long hair can be caught in moving parts.
- g. **If devices are provided for the connection of dust extraction and collection facilities, ensure these are connected and properly used.** Use of dust collection can reduce dust-related hazards.
- h. **Do not let familiarity gained from frequent use of tools allow you to become complacent and ignore, tool safety principles.** A careless action can cause severe injury within a fraction of a second.

#### 4. POWER TOOL USE AND CARE

- a. **Do not force the power tool. Use the correct power tool for your application.** The correct power tool will do the job better and safer at the rate for which it was designed.
- b. **Do not use the power tool if the switch does not turn it on and off.** Any power tool that cannot be controlled with the switch is dangerous and must be repaired.
- c. **Disconnect the plug from the power source and/or battery pack from the power tool before making any adjustments, changing accessories, or storing power tools.** Such preventive safety measures reduce the risk of starting the power tool accidentally.
- d. **Store idle power tools out of the reach of children and do not allow persons unfamiliar with the power tool or these instructions to operate the power tool.** Power tools are dangerous in the hands of untrained users.
- e. **Maintain power tools. Check for misalignment or binding of moving parts, breakage of parts and any other condition that may affect the power tool's operation. If damaged, have the power tool repaired before use.** Many accidents are caused by poorly maintained power tools.
- f. **Keep cutting tools sharp and clean.** Properly maintained cutting tools with sharp cutting edges are less likely to bind and are easier to control.
- g. **Use the power tool, accessories and tool bits etc. in accordance with these instructions taking into account the working conditions and the work to be performed.** Use of the power tool for operations different from those intended could result in a hazardous situation.
- h. **Keep handles dry, clean and free of oil and grease.** Slippery handles do not allow for safe handling and control of the tool in unexpected situations.

#### 5. SERVICE

- a. **Have your power tool serviced by a qualified repair person using only identical replacement parts.** This will ensure that the safety of the power tool is maintained.
- b. **Only use original parts for repair and maintenance.** The use of incompatible accessories or spare parts can result in electric shocks or other injuries.

## Symbols used in this manual

V.....volts

A.....amperes

Hz.....hertz

W.....watt

~.....alternating current

n .....rated speed

min<sup>-1</sup>.....revolutions or reciprocation  
per minute



.....warning of general danger



.....with electrical earth



.....read these instructions



.....always wear eye protection



.....always wear a dust mask.



.....always wear hearing protection



.....wear safety-approved hard hat



do not dispose of electric tools,  
accessories and packaging together  
with household waste material

## DRILL SAFETY WARNINGS

- **Hold power tool by insulated gripping surfaces, when performing an operation where the cutting accessory may contact hidden wiring or its own cord.** Cutting accessory contacting a "live" wire may make exposed metal parts of the power tool "live" and could give the operator an electric shock.
- **Check the ground (earth) connection of the electrical plug.**
- **Never use the machine without a PRCD fault-current safety switch.**
- **Always check the PRCD fault-current safety switch for correct functioning before starting a drilling operation.**
- **Ensure that no water is allowed to get into the motor unit during operation.**
- **If you detect a leak in any part of the water supply system, shut the machine down immediately and repair the fault. Water pressure should not exceed 70 psi (4 bar).**
- **Take care not to damage gas, water, power and other conduits in the area of the drilling operation.** Drain or shut off these conduits as required.
- **Block off the working area and place warning signs on both sides of the wall when drilling through from one side to the other.**
- **Take appropriate precautions to ensure that, in the event of a drilling core dropping out, no personal injury or material damage will result.**
- **When drilling hollow components, check the flow route of the cooling water in order to prevent damage.**
- **WARNING: Pull the plug out of the socket before making device settings or changing accessories.** Many accidents are caused by accidental starting of power tools.
- **When mounting the stand, fix the base to a firm, level, surface or wall.** The power tool cannot be guided evenly and safely if the base can slip or shake.
- **This diamond core drill cannot be used for overhead drilling unless special water control equipment is used.**

**WARNING: Hazardous situation due to broken parts: Always check core bits before using. Deformed or damaged drill core bits must not be used;**

**WARNING: Use of non-recommended cutting tools can lead to injuries due to the loss of control. Only**

use drill core bits designed for this machine only. Follow the minimum and maximum diameter given on the specifications page and do not exceed the length of the core bits beyond the maximum allowed by the drill stand. (This is usually 24" or 750mm)

**WARNING: Incorrect clamping and positioning of the drill core bit may lead to dangerous situations by broken and ejected parts of the drill core bit. Core bits must be assembled correctly. Follow the instructions below under "Fastening the Core Bit"**

**WARNING: It is necessary to always wear suitable personal protective equipment, including:**

- **Hearing protection, to reduce the risk of induced hearing loss,**
- **Gloves, when handling core bits or rough materials, to reduce injuries by sharp edges,**
- **Safety glasses, to prevent injuries by flying particles,**
- **Non-slipping footwear, to prevent injuries caused by slippery surfaces;**

**WARNING: A wrongly assembled machine may cause a hazardous situation. Follow the instructions provided with the drill stand on how to fix the machine into the stand and fixing to the material to be drilled; See also the instructions below under "Mounting to a Drilling Stand"**

## INTRODUCTION

This machine is for the intended purpose of diamond core drilling of concrete, masonry, stone and similar materials. It must always be mounted on a drilling stand. This machine is for professional use only and only trained personnel may operate this machine.

All other uses which are not for the intended purpose are prohibited.

It is equipped with a water feed system which is required for the diamond core drilling process. A PRCD interrupter (portable residual current device) which must be used at all times.

It is equipped with a three or a four speed mechanical gearbox for different core drill size ranges and features a mechanical safety clutch.

The motor has electronics for soft start, overload protection and thermal (overheating) protection. There is an overload warning to alert the operator of load and overload conditions.

The machine is equipped with spirit levels which aid in aligning the tool. Use the Tubular Level for horizontal aligning. Use the Bull's Eye Level for vertical aligning.

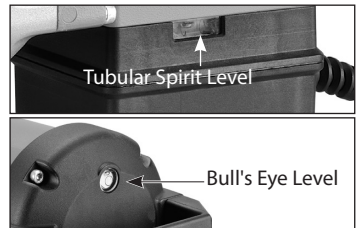

## ELECTRICAL CONNECTION

The network voltage must conform to the voltage indicated on the tool name plate.

Under no circumstances should the tool be used when the power supply cable is damaged. A damaged cable must be replaced immediately by an authorized Customer Service Center. Do not try to repair the damaged cable yourself. The use of damaged power cables can lead to an electric shock.

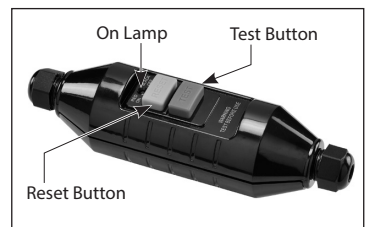

**230V models**

## 230V models:

**WARNING:** Always use the Portable Residual Current Device (PRCD) also known as a Ground Fault Circuit Interrupter (GFCI). Always use this device whenever using the machine to reduce the risk of shock hazards. Always position the device PRCD as close as possible to the power source. Test and reset the PRCD device before each use. Press the "Test" button to test. Press the "Reset" button to energize the circuit to the machine.

## 110V models:

**WARNING:** Always use a Residual Current Device (RCD) also known as a Ground Fault Circuit Interrupter (GFCI). Use an RCD in a separate control box with one or more socket outlets in accordance with EN 60309-2 with the earthing contact position 1 h. Always use this device whenever using the machine to reduce the risk of shock hazards.

**WARNING!** 110V UK machines are not equipped with a PRCD portable residual current device or GFCI ground fault circuit interrupter. The machine must always be used with an isolating transformer for protection in case an electrical fault should occur.

## ASSEMBLY

Thread the water supply assy. Into the hole in the bottom of gearbox and tighten with a wrench.

## LIST OF CONTENTS

- Diamond core drilling machine.
- Mounting spacer
- Water feed assembly
- Wrench

## OPERATING INSTRUCTIONS

### 1) MOUNTING THE CORE BIT

**CAUTION:** Ensure that the threads of the spindle and the core bit match. Attempting to mount mismatched threads will result in damage to both threads.

The spindle has two types of threads. The outside male thread is 1-1/4inch UNC, the inside female thread is 1/2 inch BSP. Ensure both the core bit and the machine spindle are clean. Any debris could cause excessive run-out of the mounted core bit. Excessive run-out can cause premature failure of the core bit and/or a safety hazard. Tighten the bit to the spindle using two wrenches. Torque to at least 200 newton meters

### Choosing the correct core bit for the job

Ensure that the bit you are using is suitable for the material you are drilling. We recommend always using wet-type (sintered) bits with this machine.

## 2) WATER SUPPLY

Water is a basic requirement for diamond core drilling. The water serves as a coolant to avoid the working surface at the tip of the bit from overheating. Never use this machine without water feed.

To connect the water supply. Attach the quick-release water coupling to a water hose.

**WARNING: Check all connections of the water feed system to ensure there are no leaks. Inspect hoses and other critical parts which could deteriorate.**

**WARNING: The maximum water pressure should not exceed 70 psi (4 bar).**

**CAUTION: There is a small indicator hole on the water feed collar. If this hole leaks water, it indicates that the water seals are worn out. Replace them immediately.**

**CAUTION: Never use this machine without water feed. Running dry will overheat and destroy its water seals.**

Use a water collector with a wet vacuum to collect cooling water if nearby objects could be damaged by water.

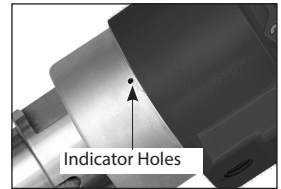
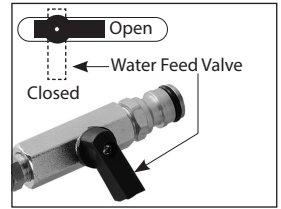

## 3) SELECTING SPEEDS

There are various ranges to suit the bit size and work piece hardness.

**CAUTION: Never attempt to change gears on a running machine! Only adjust when the machine is at rest.**

For 3 speed models, Select the desired gear range by turning the gear selector either clockwise or counterclockwise into the desired gear. It will usually be necessary to turn the spindle by hand a little to get it to shift all the way.

For 4 speed models, turn the two gear selectors to the correct combination of A,B,C and D to reach the desired speed range. (see the chart below).

### DM9

**Speed 1:**  $n_0$  550/min,  $n$  345/min

**Speed 2:**  $n_0$  1000/min,  $n$  630/min

**Speed 3:**  $n_0$  1600/min,  $n$  1000/min

### RECOMMENDED BIT Ø

152-250mm (6"-10")

102-152mm (4"- 6")

40-102mm (1-1/4"- 4")

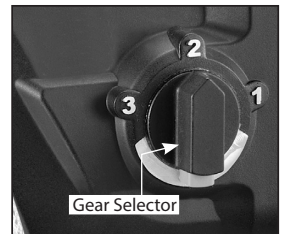

3 SPEED MODELS

### DM10

**Speed 1:**  $n_0$  450/min,  $n$  280/min

**Speed 2:**  $n_0$  810/min,  $n$  485/min

**Speed 3:**  $n_0$  1300/min,  $n$  780/min

### RECOMMENDED BIT Ø

180-300mm (7"-12")

122-180mm (5"-7")

40-122mm (1-1/2" - 5")



4 SPEED MODELS



## DM12

**Speed 1:** n<sub>0</sub> 350/min, n 220/min

**Speed 2:** n<sub>0</sub> 600/min, n 370/min

**Speed 3:** n<sub>0</sub> 1000/min, n 620/min

## RECOMMENDED BIT Ø

280-350mm (11"-14")

180-280mm (7"-11")

60-180mm (2"-7")

## DM14

**Speed 1:** AD n<sub>0</sub> 385/min, n 225/min

**Speed 2:** AC n<sub>0</sub> 530/min, n 300/min

**Speed 3:** BD n<sub>0</sub> 975/min, n 565/min

**Speed 4:** BC n<sub>0</sub> 1340/min, n 780/min

## RECOMMENDED BIT Ø

300-400mm (12"-16")

180-300mm (7"-12")

122-180mm (5"-7")

40-122mm 1-1/2"-5")

( Recommended bit size based on average hardness concrete. Speeds will vary with different material hardnesses. For reinforced concrete, speeds will be significantly slower.)

## 4) MOUNTING TO A DRILLING STAND (NOT INCLUDED)

**Warning: Do not attempt to mount to a rig that does not have a perfectly fitting mounting system.**

The motor has a standard four bolt pattern for attaching a mounting spacer. Use a mounting spacer suitable for the stand you are using to mount your drill motor to your stand. Tighten the four bolts evenly to 12Nm.

To mount to the stand, loosen the cradle lock bolt and place the mounting spacer squarely in the cradle. Then tighten the cradle lock bolt firmly to 17Nm.

The rig may be anchored to the work piece in one of three ways, with a mechanical anchor, with a vacuum base, or with a jack screw. (Follow the instructions provided with the rig.)

## TO INSTALL THE DRILL STAND

1. Measure the distance from the center of the intended cut to the location of the mounting slot in the base. Follow the concrete anchor manufacturer's instructions to install. Using an appropriate tool such as a rotary hammer, drill a correct sized hole to fit the anchor. Then drive in the anchor to below flush.
2. Move the base into position and screw in the anchor bolt, washer and nut, leaving it finger tight for the moment.
3. Using the bubble level, adjust the four leveling bolts to achieve a good level positioning, then fully tighten the center anchor bolt. The entire rig must be mounted solidly.

**WARNING: Never attempt to drill unless the stand is fixed securely beyond any doubt.**

## 5) THE SWITCH

### 230V models:

This machine has a rocker switch. Press the switch to the on position to turn on. Press the switch to the off position to turn off. If there is an interruption to the power supply, the machine will restart when the power returns.

**WARNING: Accidental starting hazard. Always ensure that the switch is in the OFF position before plunging in.**

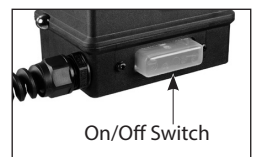

**230V models**

**WARNING: Whenever there is an interruption to the power supply, turn the switch to the OFF position to avoid an accidental restart when power returns.**

### **110V models:**

This machine has a relay-type rocker switch. Press the switch to the on position to turn on. Press the switch to the off position to turn off. Since this is a relay type switch, if there is an interruption to the power supply, the machine will not restart when the power returns. In this case first turn the switch to the off position then back to the on position to restart.



**110V models**

## **HOLE STARTING FUNCTION**

Whenever the motor is first switched on, for the first 4 seconds, it will run at 50% rotation speed. This is to aid in starting the hole. After 4 seconds, it will increase to 100% rotation speed.

## **6) OVERLOAD PROTECTION AND OVERHEAT PROTECTION**

### **Overload Warning System:**

When the load approaches overload conditions, the LED indicator light will flash on and off.

### **Overload:**

If the excessive load is sustained too long, the motor will shut down completely and the LED indicator light will glow solid red. In this case, the motor must be first shut off and then restarted.



### **Overheat Thermal Protection:**

If the temperature of the motor gets too high, the thermal protection will shut the motor down and the LED indicator light will glow solid red. The switch must be first shut off and then restarted.

**CAUTION: The motor will be damaged if it is repeatedly overloaded or overheated.**

Always cool the motor by running at no load for a few minutes whenever it stops from either overheat or overload.

## **7) SAFETY CLUTCH**

This machine is equipped with a mechanical clutch to protect the operator and machine from excessive torque forces. When the preset maximum torque level is reached, the clutch will slip.

After the clutch slips many times, it will become worn and slip at lower and lower torque levels.

When this happens, it must be serviced by an authorized service provider.

The recommended torque of the clutch nut is 21 Nm.

**CAUTION: Always ease off the load immediately whenever the clutch slips. Do not allow the clutch to continue slipping or it will wear out prematurely.**

## DRILLING INSTRUCTIONS

1. Press the "Reset" button on the PRCD interrupter device to energize the circuit to the machine. Then turn the machine on.
2. Open the water valve slightly and very gently begin the cut. Use very light feed pressure to prevent the bit from wandering until the bit is fully penetrated into the cut.
3. Make adjustments to the water feed as needed. The water leaving the cut should be a solid colored slurry with about the consistency of milk.
4. Once in the cut, use steady feed pressure.
5. When the bit is about to break through, reduce feed pressure.

**WARNING: Always keep your face away from the machine.**

## ABOUT DIAMOND BITS

The diamond impregnated segments in a wet type (sintered) diamond core bit operate on a principle of controlled erosion. The bond matrix holding the diamonds is continually worn away by abrasion with the work piece, exposing the harder diamonds to stand proud from the bond matrix. Without adequate water, the bit would overheat and be destroyed.

With too much water and not enough feed pressure, there would not be adequate erosion of the bond matrix and the bit becomes dull. This is called glazing. If the bit seems to refuse to cut anymore, it is glazed. **See below: "SHARPENING A GLAZED BIT"**

Don't feed too gently or the diamond segments will become glazed. Keep the bit steadily working. If the cut is very deep, the core plug may be obstructing the flow of cooling water. In this case, stop drilling, and chisel out the core plug before continuing.

**CAUTION: If the bit gets stuck, do not try to rock it loose by turning the switch on and off. That is hazardous and could damage the motor. Rather, unplug the machine and use a wrench on the bit mounting to work it loose.**

If embedded steel such as rebar is encountered take special care. Reduce the feed pressure by about 1/3 and let the bit go at its own pace, if there is too much vibration the bit will be destroyed. Once the steel is passed, continue normally.

**CAUTION: Drilling operations are very stressful to the motor and at the end of the cut, the motor temperature will be very hot, always run the motor at no load the temperature returns to a normal range before shutting off.**

## RESHARPENING A GLAZED BIT

If the bit becomes glazed, sharpen is by dressing with an appropriate alumina oxide or silicon carbide dressing stone. Simply drill into the stone as many times as necessary to restore its cutting performance.

## VIBRATION TROUBLESHOOTING

If vibration occurs and it is not caused by embedded steel, stop drilling to find the cause and remedy.

**CAUTION: Do not operate with vibration or there will be serious hazard and the diamond core bit will surely be destroyed.**

**Vibration is usually caused by:**

1. A bit with too much runout  
**SOLUTION:** Replace bit.
2. A bit with diamond segments broken off  
**SOLUTION:** Replace bit.
3. Shifted base or loose gibs  
**SOLUTION:** Retighten mountings or adjust gibs as needed.

## MAINTENANCE

Every 50 hours of operation blow compressed air through the motor while running at no load to clean out accumulated dust. Always check for a damaged power supply cable, check for loose fasteners and always keep alert for unusual noises and vibration when operating.

**WARNING: Never operate a damaged machine. Always tag a damaged machine and take it out of service until repairs can be made.**

**CAUTION: This machine is equipped with an oil bath gearbox. To avoid leakage of lubricating oil, whenever the gearbox is opened, the o-ring seal must be replaced with a new one.**

**CAUTION: If the gear oil is found to be leaking out, have the machine repaired by a qualified service center immediately. Running without sufficient oil will lead to certain damage of the gearbox.**

Maintenance which should be performed by an authorized service center, include the following:

- Replace water seals as needed.
- Replace the carbon brushes as needed
- Change the gear oil about every 100 hours of operation
- Replace the clutch discs and spring as needed.

## THE CARBON BRUSHES

The carbon brushes are a normal wearing part and must be replaced when they reach their wear limit. This machine is equipped with auto-stop carbon brushes. If the machine comes to a stop unexpectedly, the brushes should be checked. The auto-stop brush design protects the motor by stopping the machine before the carbon brushes are completely worn out.

**Caution: Always replace the brushes as a pair.**

## To replace

1. Remove the 4 screws and remove the motor tail cover.
2. Using pliers rotate the brush spring out of the way and slide the old carbon brush out of the brush holder.
3. Unscrew the screw to remove the brush lead. The old carbon brush may now be lifted away.
4. Install a new brush. Installation is the reverse of removal.
5. Replace the motor tail cover. Take care not to pinch any wires when reassembling.

**If the replacement of the power supply cord is necessary, this has to be done by the manufacturer or their agent in order to avoid a safety hazard.**

**WARNING: All repairs must be entrusted to an authorized service center.** Incorrectly performed repairs could lead to injury or death.

Do not throw electric power tools into the household waste! In accordance with the European Directive 2002/96/EG on Waste Electrical and Electronic Equipment and transposition into national law, used electric power tools must be collected separately and recycled in an environmentally friendly manner.

# Exploded View DM14

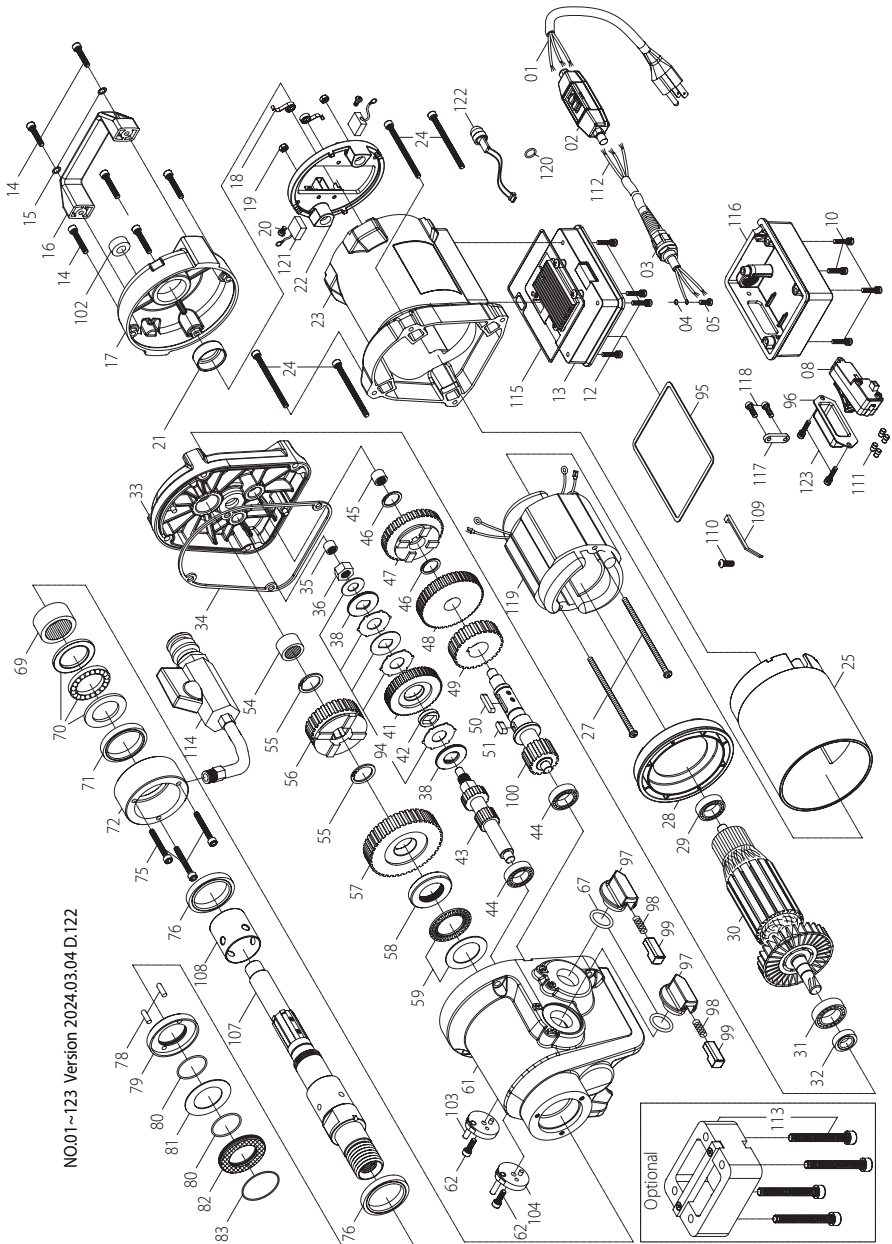

## Parts List DM14

NO.	Parts Name	Q'TY	NO.	Parts Name	Q'TY
1	POWER SUPPLY CABLE (VDE-1.5x3Cx1.4M-H07RNF)	1	57	OUTPUT GEAR (M2.0x40T)	1
2	PRCD INTERRUPTER PROTECTION (220V)	1	58	CLUTCH NUT (M27xP1.0x7.8T)	1
3	CORD ARMOR	1	59	THRUST BEARING (NTB3047 + AS3047)	1
4	EXTERNAL STAR WASHER (M4)	1	61	GEAR HOUSING	1
5	PANHEAD MACHINE SCREW (M4x10xP0.7)	1	62	SOCKET CAP SCREW (M5x12xP0.8)	2
8	SWITCH (110V)	1	67	O-RING (Ø20x3)	2
10	PANHEAD TAPPING SCREW (M4x25)	4	69	NEEDLE BEARING (TA3020)	1
12	PANHEAD MACHINE SCREW (M4x12xP0.7)	4	70	THRUST BEARING (S1106)	1
13	ELECTRONICS UNIT (220V)	1	71	OIL SEAL (Ø40xØ50x7)	1
14	SOCKET CAP SCREW-SUS (M5-0.8 x 25)	6	72	WATER FEED COLLAR	1
15	FLAT WASHER (Ø5xØ12x1)	2	75	SOCKET CAP SCREW (M5x40xP0.8)	3
16	TOP HANDLE	1	76	OIL SEAL (Ø40xØ52x7)	2
17	MOTOR END CASTING	1	78	DOWEL PIN (Ø4x11.8)	2
18	BRUSH SPRING (0.4x4x3T)	2	79	ANTI-SEIZE CUP	1
19	NYLOCK NUT (M5xP0.8)	2	80	O-RING (Ø32x1.5)	2
20	PANHEAD MACHINE SCREW (M4x6xP0.7)	2	81	THRUST RING (3252)	1
21	RUBBER BEARING SLEEVE	1	82	ANTI-SEIZE RING	1
22	BRUSH HOLDER PLATE ASSY.	1	83	O-RING (Ø45x1.5)	1
23	MOTOR HOUSING	1	94	CLUTCH DISC SET	1
24	SOCKET CAP SCREW-SUS (M6-1.0 x 75)	4	95	GASKET	1
25	MOTOR INSULATION SLEEVE	1	96	SWITCH BOOT	1
27	PANHEAD MACHINE SCREW (M5x110xP0.8)	2	97	GEAR SELECTOR	1
28	FAN SHROUD	1	98	SPRING (Ø0.6xØ3.8xØ5x11Tx35L)	2
29	BALL BEARING (6200)	1	99	RELEASE PIN	1
30	ARMATURE (220V-100x54.1x75)	1	100	COUNTERSHAFT SET	1
31	BALL BEARING (6202)	1	102	BULLS-EYE LEVEL	1
32	OIL SEAL (Ø14xØ25x7)	1	103	SELECTOR DISC	1
33	GEAR PLATE	1	104	SELECTOR DISC	1
34	GASKET	1	107	SPINDLE SET (1 1/4"-7 x 1/2"BSP-300.5MM)	1
35	NEEDLE BEARING (HK 0810)	1	108	STAINLESS BUSHING	1
36	CLUTCH NUT (M12xP1.75x9T)	1	109	ZIP TIE (TCVS-170)	1
38	PRESSURE DISC (Ø34.8xØ16x2.5)	2	110	PANHEAD TAPPING SCREW (M4x16)	1
41	INPUT GEAR (M1.25x44T)	1	111	BUTT SPLICE CONNECTORS	4
42	BUSHING (Ø15.9xØ22x4.7)	1	112	POWER SUPPLY CABLE (NO PLUG-1.5x3Cx2.1M-H07RNF)	1
43	INPUT SHAFT (M1.75x13TxM1.5x12T)	1	113	EXTENSION SPACER	1
44	BALL BEARING (6200)	2	114	WATER FEED CONNECTOR KIT (1/2")	1
45	NEEDLE BEARING (HK 1010)	1	115	GASKET	1
46	INTERNAL CIRCLIP (I518)	2	116	COVER (110V&220V)	1
47	SLIDER GEAR-CD (M1.75x36T)	1	117	CABLE CLIP	1
48	LAY GEAR (M1.5x46T)	1	118	PANHEAD TAPPING SCREW (M4x14)	2
49	COUNTERSHAFT GEAR (M2.0x26T)	1	119	STATOR (220V-100x54.1x75)	1
50	PARALLEL KEY (5x5x25)	1	120	O-RING (Ø6x2)	1
51	PARALLEL KEY (6x6x15)	1	121	CARBON BRUSH (7x17x19)(220V)	2
54	NEEDLE BEARING (TA1815)	1	122	LED INDICATOR LIGHT	1
55	INTERNAL CIRCLIP (I525)	2	123	PANHEAD TAPPING SCREW (M4x12)	2
56	SLIDER GEAR-AB (M2.0x28T)	1	*	GEAR OIL (625cc)	1

# Exploded View DM12

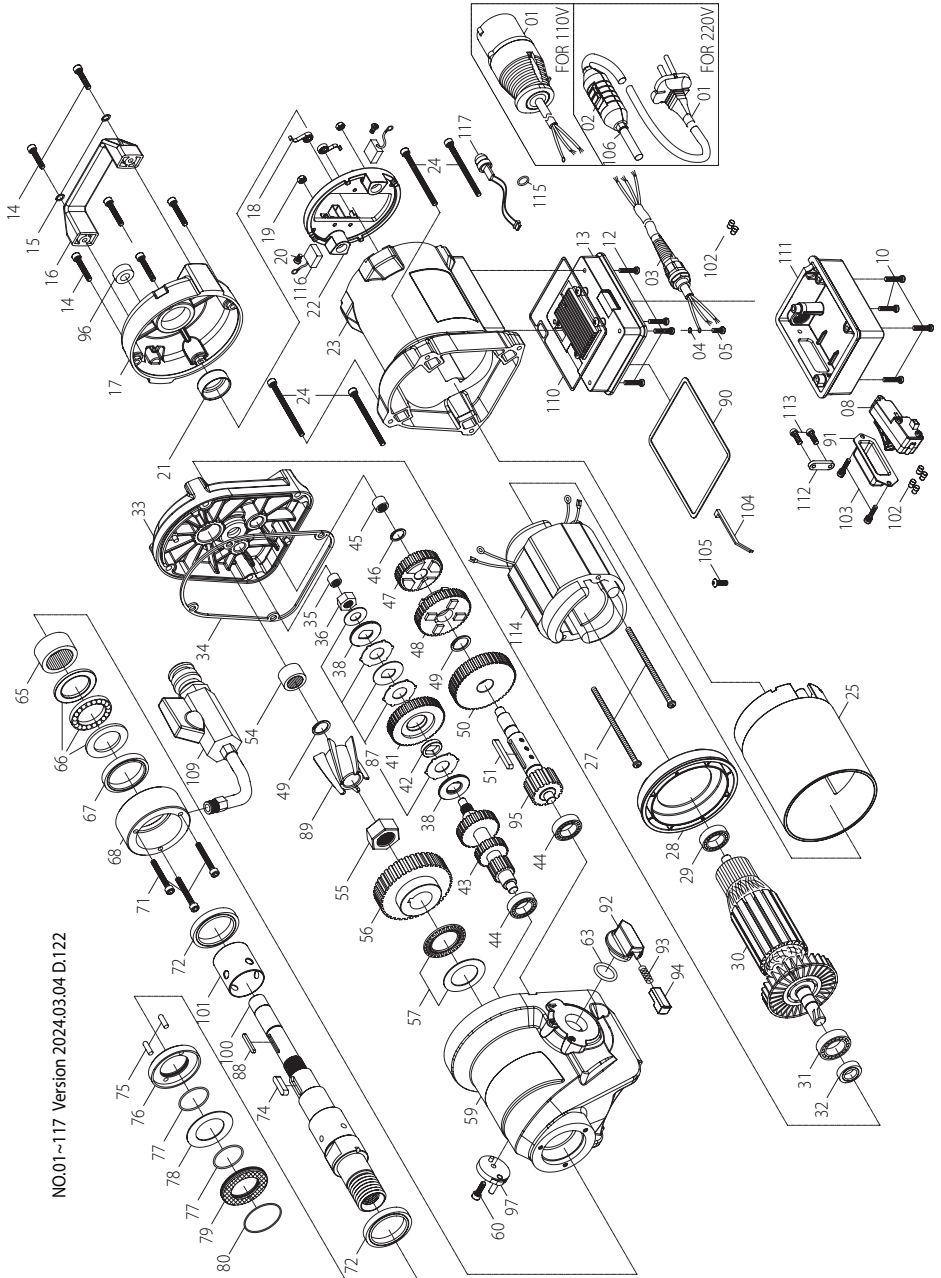



## Parts List DM12

NO.	Parts Name	Q'TY	NO.	Parts Name	Q'TY
1	POWER SUPPLY CABLE (UK-2.5x3Cx3.5M-H07RNF)	1	56	OUTPUT GEAR (M2.0x41T)	1
1	POWER SUPPLY CABLE (VDE-1.5x3Cx1.4M-H07RNF)	1	57	THRUST BEARING (NTB3047 + AS3047)	1
2	PRCD INTERRUPTER PROTECTION (220V)	1	59	GEAR HOUSING	1
3	CORD ARMOR	1	60	SOCKET CAP SCREW (M5-0.8 x 12)	1
4	EXTERNAL STAR WASHER (M4)	1	63	O-RING (Ø20x3)	1
5	PANHEAD MACHINE SCREW (M4x10xP0.7)	1	65	NEEDLE BEARING (TA3020)	1
8	SWITCH (110V)	1	66	THRUST BEARING (S1106)	1
10	PANHEAD TAPPING SCREW (M4x25)	4	67	OIL SEAL (Ø40xØ50x7)	1
12	PANHEAD MACHINE SCREW (M4x12xP0.7)	4	68	WATER FEED COLLAR	1
13	ELECTRONICS UNIT (110V/220V)	1	71	SOCKET CAP SCREW (M5x40xP0.8)	3
14	SOCKET CAP SCREW-SUS (M5-0.8 x 25)	6	72	OIL SEAL (Ø40xØ52x7)	2
15	FLAT WASHER (Ø5xØ12x1)	2	74	PARALLEL KEY (6x6x25)	1
16	TOP HANDLE	1	75	DOWEL PIN (Ø4x11.8)	2
17	MOTOR END CASTING	1	76	ANTI-SEIZE CUP	1
18	BRUSH SPRING (0.4x4x3T)	2	77	O-RING (Ø32x1.5)	2
19	NYLOCK NUT (M5xP0.8)	2	78	THRUST RING (3252)	1
20	PANHEAD MACHINE SCREW (M4x6xP0.7)	2	79	ANTI-SEIZE RING	1
21	RUBBER BEARING SLEEVE	1	80	O-RING (Ø45x1.5)	1
22	BRUSH HOLDER PLATE ASSY.	1	87	CLUTCH DISC SET	1
23	MOTOR HOUSING	1	88	PARALLEL KEY (4x4x30)	1
24	SOCKET CAP SCREW-SUS (M6-1.0 x 75)	4	89	OIL IMPELLER	1
25	MOTOR INSULATION SLEEVE	1	90	GASKET	1
27	PANHEAD MACHINE SCREW (M5x110xP0.8)	2	91	SWITCH BOOT	1
28	FAN SHROUD	1	92	GEAR SELECTOR	1
29	BALL BEARING (6200)	1	93	SPRING (Ø0.6xØ3.8xØ5x11Tx35L)	1
30	ARMATURE (110V/220V-100x54.1x75)	1	94	RELEASE PIN	1
31	BALL BEARING (6202)	1	95	COUNTERSHAFT SET	1
32	OIL SEAL (Ø14xØ25x7)	1	96	BULLS-EYE LEVEL	1
33	GEAR PLATE	1	97	SELECTOR DISC	1
34	GASKET	1	100	SPINDLE (1 1/4"-7x1/2" BSP-296.5MM)	1
35	NEEDLE BEARING (HK 0810)	1	101	STAINLESS BUSHING	1
36	CLUTCH NUT (M12xP1.75x9T)	1	102	BUTT SPLICE CONNECTORS	4
38	PRESSURE DISC (Ø34.8xØ16x2.5)	2	103	PANHEAD TAPPING SCREW (M4x12)	2
41	INPUT GEAR (M1.25x44T)	1	104	ZIP TIE (TCVS-170)	1
42	BUSHING (Ø15.9xØ22x4.7)	1	105	PANHEAD TAPPING SCREW (M4x16)	1
43	INPUT SHAFT (M1.5x27xM1.5x20TxM1.5x13T)	1	106	POWER SUPPLY CABLE (NO PLUG-1.5x3Cx2.1M-H07RNF)	1
44	BALL BEARING (6200)	2	109	WATER FEED CONNECTOR KIT (1/2")	1
45	NEEDLE BEARING (HK 1010)	1	110	GASKET	1
46	INTERNAL CIRCLIP (IS14)	1	111	COVER (110V&220V)	1
47	COUNTERSHAFT SET	1	112	CABLE CLIP	1
48	SPINDLE GEAR (M1.5x38T)	1	113	PANHEAD TAPPING SCREW (M4x14)	2
49	INTERNAL CIRCLIP (IS18)	2	114	STATOR (110V/220V-100x54.1x75)	1
50	LAY GEAR (M1.5x45T)	1	115	O-RING (Ø6x2)	1
51	PARALLEL KEY (5x5x40)	1	116	CARBON BRUSH (7x17x19)(110V/220V)	2
54	NEEDLE BEARING (TA1815)	1	117	LED INDICATOR LIGHT	1
55	NYLOOK NUT (M20xP1.5)	1	*	GEAR OIL (625cc)	1

# Exploded View DM10

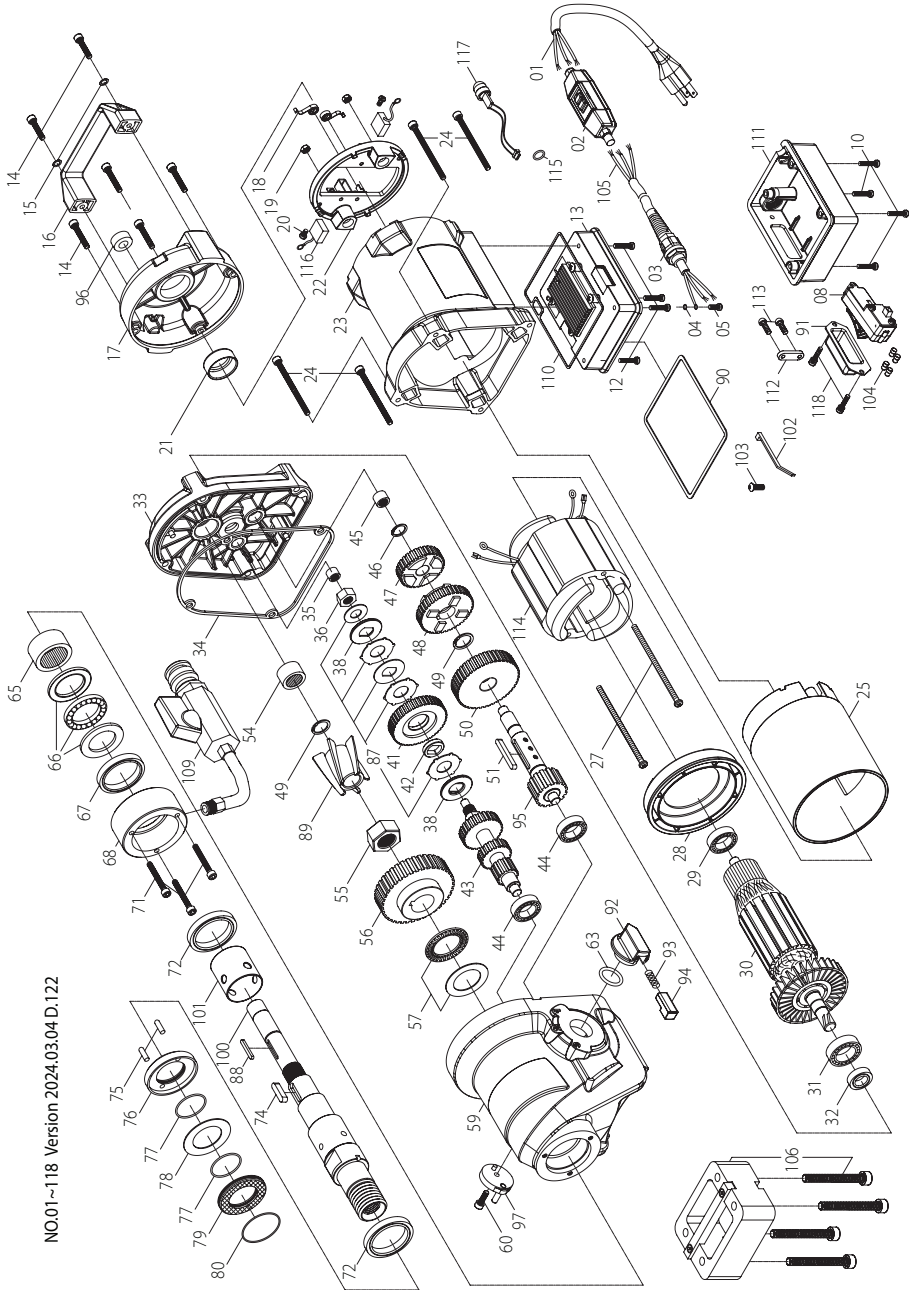

NO.01~118 Version 2024.03.04-D.122

## Parts List DM10

NO.	Parts Name	Q'TY	NO.	Parts Name	Q'TY
1	POWER SUPPLY CABLE (VDE-1.5x3Cx1.4M-H07RNF)	1	57	THRUST BEARING (NTB3047 + AS3047)	1
2	PRCD INTERRUPTER PROTECTION (220V)	1	59	GEAR HOUSING	1
3	CORD ARMOR	1	60	SOCKET CAP SCREW (M5x12xP0.8)	1
4	EXTERNAL STAR WASHER (M4)	1	63	O-RING (Ø20x3)	1
5	PANHEAD MACHINE SCREW (M4x10xP0.7)	1	65	NEEDLE BEARING (TA3020)	1
8	SWITCH (110V)	1	66	THRUST BEARING (51106)	1
10	PANHEAD TAPPING SCREW (M4x25)	4	67	OIL SEAL (Ø40xØ50x7)	1
12	PANHEAD MACHINE SCREW (M4x12xP0.7)	4	68	WATER FEED COLLAR	1
13	ELECTRONICS UNIT (220V)	1	71	SOCKET CAP SCREW (M5x40xP0.8)	3
14	SOCKET CAP SCREW-SUS (M5-0.8 x 25)	6	72	OIL SEAL (Ø40xØ52x7)	2
15	FLAT WASHER (Ø5xØ12x1)	2	74	PARALLEL KEY (6x6x25)	1
16	TOP HANDLE	1	75	DOWEL PIN (Ø4x11.8)	2
17	MOTOR END CASTING	1	76	ANTI-SEIZE CUP	1
18	BRUSH SPRING (0.4x4x3T)	2	77	O-RING (Ø32x1.5)	2
19	NYLOCK NUT (M5xP0.8)	2	78	THRUST RING (3252)	1
20	PANHEAD MACHINE SCREW (M4x6xP0.7)	2	79	ANTI-SEIZE RING	1
21	RUBBER BEARING SLEEVE	1	80	O-RING (Ø45x1.5)	1
22	BRUSH HOLDER PLATE ASSY.	1	87	CLUTCH DISC SET	1
23	MOTOR HOUSING	1	88	PARALLEL KEY (4x4x30)	1
24	SOCKET CAP SCREW-SUS (M6-1.0 x 75)	4	89	OIL IMPELLER	1
25	MOTOR INSULATION SLEEVE	1	90	GASKET	1
27	PANHEAD MACHINE SCREW (M5x110xP0.8)	2	91	SWITCH BOOT	1
28	FAN SHROUD	1	92	GEAR SELECTOR	1
29	BALL BEARING (6200)	1	93	SPRING (Ø0.6xØ3.8xØ5x11Tx35L)	1
30	ARMATURE (220V-100x54.1x75)	1	94	RELEASE PIN	1
31	BALL BEARING (6202)	1	95	COUNTERSHAFT SET	1
32	OIL SEAL (Ø14xØ25x7)	1	96	BULLS-EYE LEVEL	1
33	GEAR PLATE	1	97	SELECTOR DISC	1
34	GASKET	1	100	SPINDLE (1 1/4"-7x1/2" BSP-296.5MM)	1
35	NEEDLE BEARING (HK 0810)	1	101	STAINLESS BUSHING	1
36	CLUTCH NUT (M12xP1.75x9T)	1	102	ZIP TIE (TCVS-170)	1
38	PRESSURE DISC (Ø34.8xØ16x2.5)	2	103	PANHEAD TAPPING SCREW (M4x16)	1
41	INPUT GEAR (M1.25x44T)	1	104	BUTT SPLICE CONNECTORS	4
42	BUSHING (Ø15.9xØ22x4.7)	1	105	POWER SUPPLY CABLE (NO PLUG-1.5x3Cx2.1M-H07RNF)	1
43	INPUT SHAFT (M1.5x27TxM1.5x20TxM1.5x13T)	1	106	EXTENSION SPACER	1
44	BALL BEARING (6200)	2	109	WATER FEED CONNECTOR KIT (1/2")	1
45	NEEDLE BEARING (HK 1010)	1	110	GASKET	1
46	INTERNAL CIRCLIP (IS14)	1	111	COVER (110V&220V)	1
47	COUNTERSHAFT SET	1	112	CABLE CLIP	1
48	SPINDLE GEAR (M1.5x38T)	1	113	PANHEAD TAPPING SCREW (M4x14)	2
49	INTERNAL CIRCLIP (IS18)	2	114	STATOR (220V-100x54.1x75)	1
50	LAY GEAR (M1.5x45T)	1	115	O-RING (Ø6x2)	1
51	PARALLEL KEY (5x5x40)	1	116	CARBON BRUSH (7x17x19)(220V)	2
54	NEEDLE BEARING (TA1815)	1	117	LED INDICATOR LIGHT	1
55	NYLOCK NUT (M20xP1.5)	1	118	PANHEAD TAPPING SCREW (M4x12)	2
56	OUTPUT GEAR (M2.0x39T)	1	*	GEAR OIL (625cc)	1

# Exploded View DM9

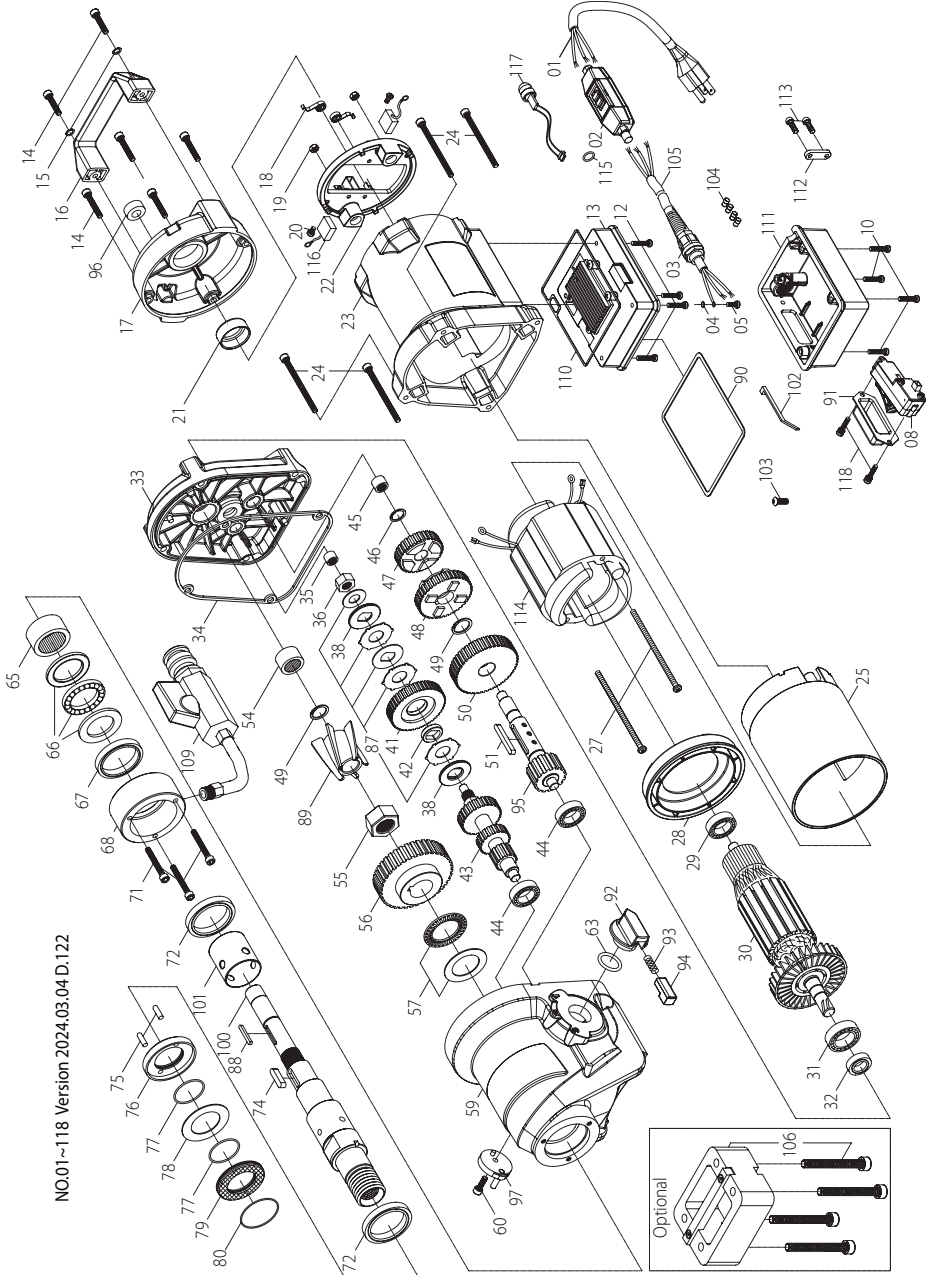

NO.01~118 Version 2024.03.04 D.122

## Parts List DM9

NO.	Parts Name	Q'TY	NO.	Parts Name	Q'TY
1	POWER SUPPLY CABLE (VDE-1.5x3Cx1.4M-H07RNF)	1	57	THRUST BEARING (NTB3047 + AS3047)	1
2	PRCD INTERRUPTER PROTECTION (220V)	1	59	GEAR HOUSING	1
3	CORD ARMOR	1	60	SOCKET CAP SCREW (M5x12xP0.8)	1
4	EXTERNAL STAR WASHER (M4)	1	63	O-RING (Ø20x3)	1
5	PANHEAD MACHINE SCREW (M4x10xP0.7)	1	65	NEEDLE BEARING (TA3020)	1
8	REED SWITCH (110V&220V)	1	66	THRUST BEARING (51106)	1
10	PANHEAD TAPPING SCREW (M4x25)	4	67	OIL SEAL (Ø40xØ50x7)	1
12	PANHEAD MACHINE SCREW (M4x12xP0.7)	4	68	WATER FEED COLLAR	1
13	ELECTRONICS UNIT (220V)	1	71	SOCKET CAP SCREW (M5x40xP0.8)	3
14	SOCKET CAP SCREW-SUS (M5-0.8 x 25)	6	72	OIL SEAL (Ø40xØ52x7)	2
15	FLAT WASHER (Ø5xØ12x1)	2	74	PARALLEL KEY (6x6x25)	1
16	TOP HANDLE	1	75	DOWEL PIN (Ø4x11.8)	2
17	MOTOR END CASTING	1	76	ANTI-SEIZE CUP	1
18	BRUSH SPRING (0.4x4x3T)	2	77	O-RING (Ø32x1.5)	2
19	NYLOCK NUT (M5xP0.8)	2	78	THRUST RING (3252)	1
20	PANHEAD MACHINE SCREW (M4x6xP0.7)	2	79	ANTI-SEIZE RING	1
21	RUBBER BEARING SLEEVE	1	80	O-RING (Ø45x1.5)	1
22	BRUSH HOLDER PLATE ASSY.	1	87	CLUTCH DISC SET	1
23	MOTOR HOUSING	1	88	PARALLEL KEY (4x4x30)	1
24	SOCKET CAP SCREW-SUS (M6-1.0 x 75)	4	89	OIL IMPELLER	1
25	MOTOR INSULATION SLEEVE	1	90	GASKET	1
27	PANHEAD MACHINE SCREW (M5x110xP0.8)	2	91	SWITCH BOOT	1
28	FAN SHROUD	1	92	GEAR SELECTOR	1
29	BALL BEARING (6200)	1	93	SPRING (Ø0.6Ø03.8xØ5x11Tx35L)	1
30	ARMATURE (220V-100x54.1x75)	1	94	RELEASE PIN	1
31	BALL BEARING (6202)	1	95	COUNTERSHAFT SET	1
32	OIL SEAL (Ø14xØ25x7)	1	96	BULLS-EYE LEVEL	1
33	GEAR PLATE	1	97	SELECTOR DISC	1
34	GASKET	1	100	SPINDLE (1 1/4"-7x1/2"BSP-296.5MM)	1
35	NEEDLE BEARING (HK 0810)	1	101	STAINLESS BUSHING	1
36	CLUTCH NUT (M12xP1.75x9T)	1	102	ZIP TIE (TCVS-170)	1
38	PRESSURE DISC (Ø34.8xØ16x2.5)	2	103	PANHEAD TAPPING SCREW (M4x16)	1
41	INPUT GEAR (M1.25x44T)	1	104	BUTT SPLICE CONNECTORS	4
42	BUSHING (Ø15.9xØ22x4.7)	1	105	POWER SUPPLY CABLE (NO PLUG-1.5x3Cx2.1M-H07RNF)	1
43	INPUT SHAFT (M1.5x27TxM1.5x20TxM1.5x13T)	1	106	EXTENSION SPACER	1
44	BALL BEARING (6200)	2	109	WATER FEED CONNECTOR KIT (1/2")	1
45	NEEDLE BEARING (HK 1010)	1	110	GASKET	1
46	INTERNAL CIRCLIP (I514)	1	111	COVER (110V&220V)	1
47	COUNTERSHAFT SET	1	112	CABLE CLIP	1
48	SPINDLE GEAR (M1.5x38T)	1	113	PANHEAD TAPPING SCREW (M4x14)	2
49	INTERNAL CIRCLIP (I518)	2	114	STATOR (220V-100x54.1x75)	1
50	LAY GEAR (M1.5x45T)	1	115	O-RING (Ø6x2)	1
51	PARALLEL KEY (5x5x40)	1	116	CARBON BRUSH (7x17x20)(220V)	2
54	NEEDLE BEARING (TA1815)	1	117	LED INDICATOR LIGHT	1
55	NYLOOK NUT (M20xP1.5)	1	118	PANHEAD TAPPING SCREW (M4x12)	2
56	OUTPUT GEAR (M2.0x35T)	1	*	GEAR OIL (625cc)	1

# WIRING

220V

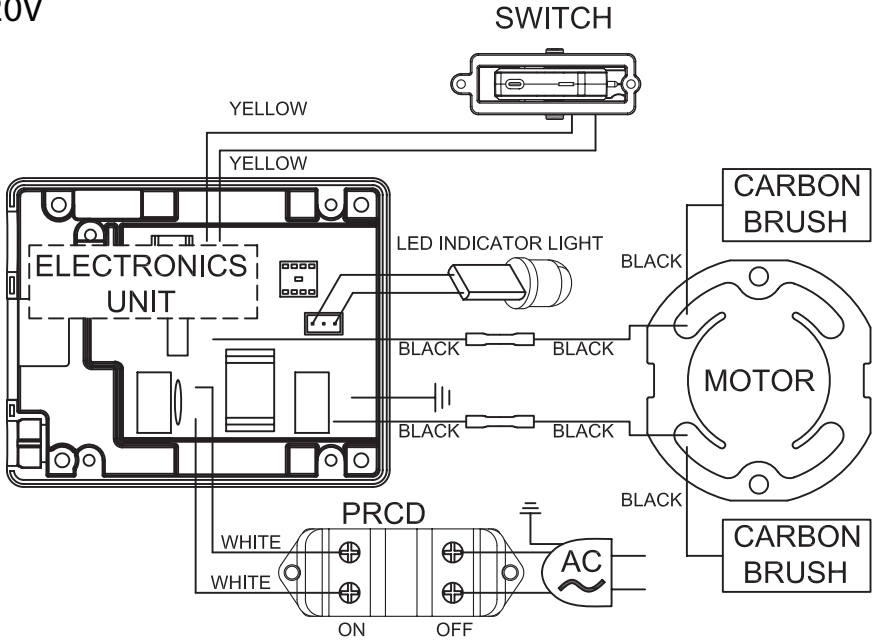

110V

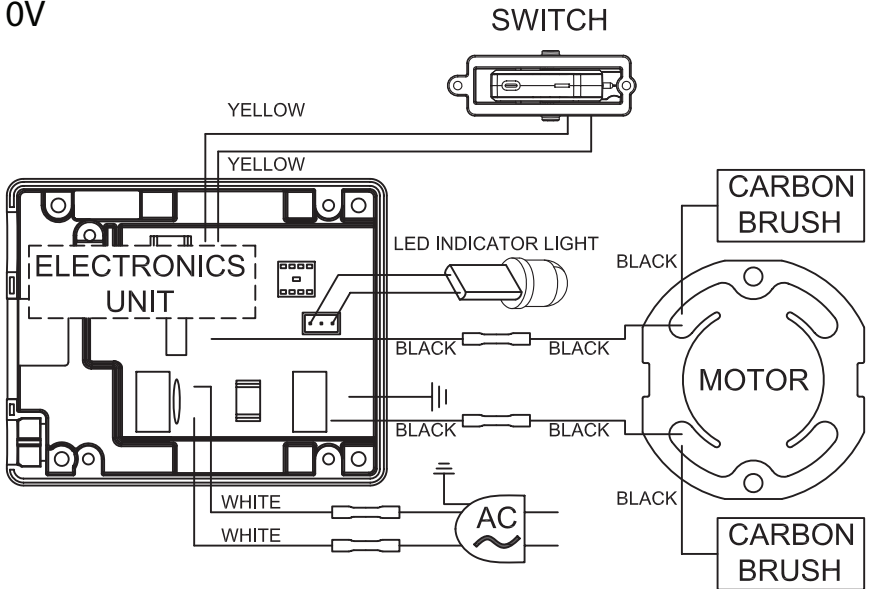

## Noise information

Measured in accordance with EN 61029-2-6

**Model no. : DM9, DM10, DM12, DM14**

**Noise level:** Sound pressure level( $L_{pA}$ ):87.0 db(A)    Sound power level( $L_{WA}$ ):100.0 db(A)    K= 3 db(A)

## CE Declaration of Conformity

•We declare under our sole responsibility that this product is in conformity with the following standards or standardized documents: EN 61029-1:2009+A11:2010 & EN 61029-2-6:2010 EN 55014-1:2006+A1:2009+A2:2011; EN55014-2:1997+A1:2001+A2:2008; EN 61000-3-2:2014; EN61000-3-3:2013 in accordance with the regulations 2014/30/EU, 2006/42/EC, 2011/65/EU

•Technical file at: LEE YEONG INDUSTRIAL CO., LTD., NO.2, KEJIA RD., DOULIU CITY, YUNLIN COUNTY 64057, TAIWAN

You-Chun, Liu  
Operation & Engineering

*You chun Liu*

Chih-Hao, Lai  
Approval Manager

*chih hao lai*

LEE YEONG INDUSTRIAL CO., LTD.,  
NO.2, KEJIA RD., DOULIU CITY, YUNLIN COUNTY 64057, TAIWAN    12.27.2016

**LEE YEONG INDUSTRIAL CO., LTD.**

NO.2, KEJIA RD., DOULIU CITY,  
YUNLIN COUNTY 64057, TAIWAN

TEL: 886-5-5518689 (REP)

Fax: 886-5-5518635

