

# AGP<sup>®</sup>

## Drill Motor

DM20

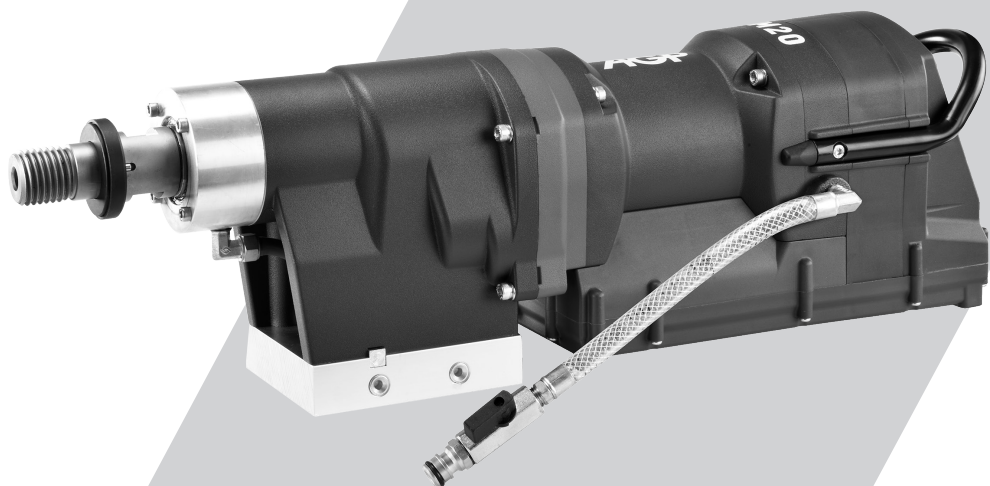

## Instruction Manual

CE CB



## TECHNICAL DATA

Power Input	16 A, 3700 W (230 V)
Voltage	220-240 V, 50-60 Hz
Rated Load Speeds	220 - 540 /min
Drilling Capacity	Ø 500 mm (20")
Gear Oil Type	90W
Spindle Thread	1-¼" UNC male
Insulation Class	Class 1 with RCD
Ingress Protection Class	IP55
Weight	16.7 kg (36.7 lb)

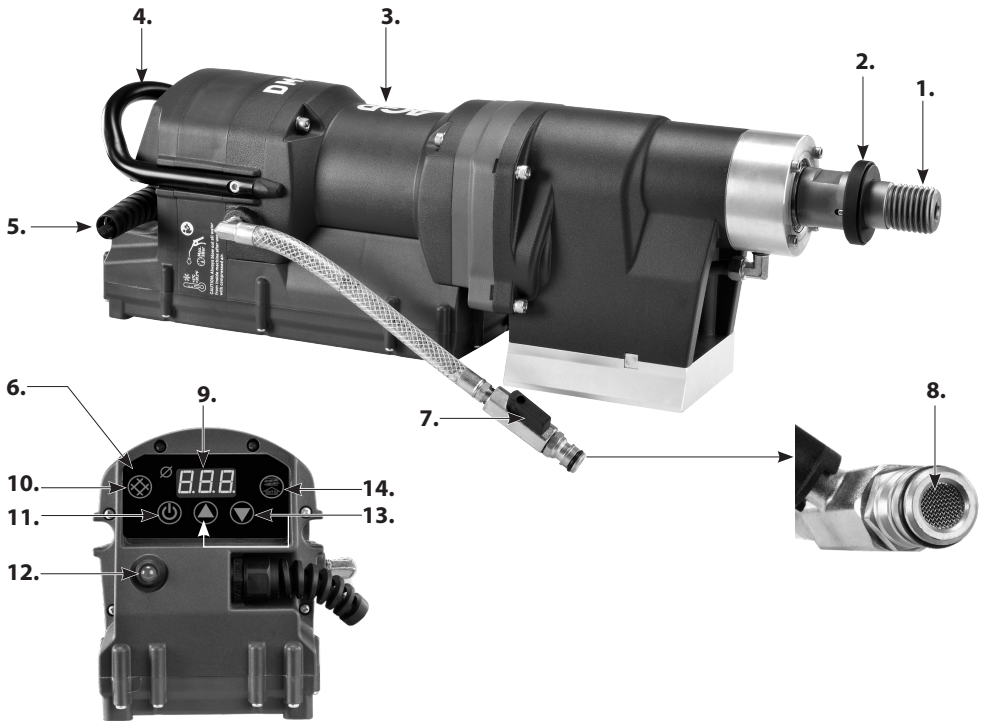

- |   |   |
|---|---|
| <ul style="list-style-type: none"> <li>1. Spindle</li> <li>2. Anti-Seize Ring</li> <li>3. Motor Unit</li> <li>4. Tail Handle</li> <li>5. Power Supply Cord</li> <li>6. Control Panel</li> <li>7. Water Feed Valve</li> <li>8. Water Inlet Strainer</li> </ul> | <ul style="list-style-type: none"> <li>9. Information Screen</li> <li>10. Rebar Assist Button<br/>(also used to change from mm to inch display)</li> <li>11. Motor On/Off Button (Starts and Stops the motor)</li> <li>12. LED Load Indicator</li> <li>13. Diameter Selector Buttons</li> <li>14. Bit Threading Button (only active when motor is OFF)</li> </ul> |
|---|---|

# GENERAL SAFETY RULES



**WARNING! Read all safety warnings and all instructions.** Failure to follow the warnings and instructions may result in electric shock, fire and/or serious injury.

**Save all warnings and instructions for future reference.**

The term “power tool” in the warnings refers to your mains-operated (corded) power tool or battery-operated (cordless) power tool.

## 1. WORK AREA SAFETY

- a. **Keep work area clean and well lit.** Cluttered and dark areas invite accidents.
- b. **Do not operate power tools in explosive atmospheres, such as in the presence of flammable liquids, gases or dust.** Power tools create sparks which may ignite the dust or fumes.
- c. **Keep children and bystanders away while operating a power tool.** Distractions can cause you to lose control.
- d. **Never leave the electric power tool unattended.** Only leave the machine when the tool in use has come to a complete standstill.

## 2. ELECTRICAL SAFETY

- a. **Power tool plugs must match the outlet. Never modify the plug in any way. Do not use any adapter plugs with earthed (grounded) power tools.** Unmodified plugs and matching outlets will reduce risk of electric shock.
- b. **Avoid body contact with earthed or grounded surfaces, such as pipes, radiators, ranges and refrigerators.** There is an increased risk of electric shock if your body is earthed or grounded.
- c. **Do not expose power tools to rain or wet conditions.** Water entering a power tool will increase the risk of electric shock.
- d. **Do not abuse the cord. Never use the cord for carrying, pulling or unplugging the power tool. Keep cord away from heat, oil, sharp edges or moving parts.** Damaged or entangled cords increase the risk of electric shock.
- e. **When operating a power tool outdoors, use an extension cord suitable for outdoor use.** Use of a cord suitable for outdoor use reduces the risk of electric shock.
- f. **If operating a power tool in a damp location is unavoidable, use a residual current device (RCD) protected supply.** Use of an RCD reduces the risk of electric shock.

## 3. PERSONAL SAFETY

- a. **Stay alert, watch what you are doing and use common sense when operating a power tool. Do not use a power tool while you are tired or under the influence of drugs, alcohol or medication.** A moment of inattention while operating power tools may result in serious personal injury.
- b. **Use personal protective equipment. Always wear eye protection.** Protective equipment such as dust mask, non-skid safety shoes, hard hat, or hearing protection used for appropriate conditions will reduce personal injuries.

- c. **Prevent unintentional starting. Ensure the switch is in the off-position before connecting to power source and/or battery pack, picking up or carrying the tool.** Carrying power tools with your finger on the switch or energising power tools that have the switch on invites accidents.
- d. **Remove any adjusting key or wrench before turning the power tool on.** A wrench or a key left attached to a rotating part of the power tool may result in personal injury.
- e. **Do not overreach. Keep proper footing and balance at all times.** This enables better control of the power tool in unexpected situations.
- f. **Dress properly. Do not wear loose clothing or jewellery. Keep your hair and clothing away from moving parts.** Loose clothes, jewellery or long hair can be caught in moving parts.
- g. **If devices are provided for the connection of dust extraction and collection facilities, ensure these are connected and properly used.** Use of dust collection can reduce dust related hazards.
- h. **Do not let familiarity gained from frequent use of tools allow you to become complacent and ignore tool safety principles.** A careless action can cause severe injury within a fraction of a second.

#### 4. POWER TOOL USE AND CARE

- a. **Do not force the power tool. Use the correct power tool for your application.** The correct power tool will do the job better and safer at the rate for which it was designed.
- b. **Do not use the power tool if the switch does not turn it on and off.** Any power tool that cannot be controlled with the switch is dangerous and must be repaired.
- c. **Disconnect the plug from the power source and/or battery pack from the power tool before making any adjustments, changing accessories, or storing power tools.** Such preventive safety measures reduce the risk of starting the power tool accidentally.
- d. **Store idle power tools out of the reach of children and do not allow persons unfamiliar with the power tool or these instructions to operate the power tool.** Power tools are dangerous in the hands of untrained users.
- e. **Maintain power tools. Check for misalignment or binding of moving parts, breakage of parts and any other condition that may affect the power tool's operation. If damaged, have the power tool repaired before use.** Many accidents are caused by poorly maintained power tools.
- f. **Keep cutting tools sharp and clean.** Properly maintained cutting tools with sharp cutting edges are less likely to bind and are easier to control.
- g. **Use the power tool, accessories and tool bits etc. in accordance with these instructions taking into account the working conditions and the work to be performed.** Use of the power tool for operations different from those intended could result in a hazardous situation.
- h. **Keep handles dry, clean and free of oil and grease.** Slippery handles do not allow for safe handling and control of the tool in unexpected situations.

#### 5. SERVICE

- a. **Have your power tool serviced by a qualified repair person using only identical replacement parts.** This will ensure that the safety of the power tool is maintained.
- b. **Only use original parts for repair and maintenance.** The use of incompatible accessories or spare parts can result in electric shocks or other injuries.

## Symbols used in this manual

V.....volts

A.....amperes

Hz.....hertz

W.....watt

~.....alternating current

n .....rated speed

min<sup>-1</sup>.....revolutions or reciprocation  
per minute



.....warning of general danger



.....with electrical earth



.....read these instructions



.....always wear eye protection



.....always wear a dust mask.



.....always wear hearing protection



.....wear safety-approved hard hat



do not dispose of electric tools,  
accessories and packaging together  
with household waste material

## DRILL SAFETY WARNINGS

- **Hold power tool by insulated gripping surfaces, when performing an operation where the cutting accessory may contact hidden wiring or its own cord.** Cutting accessory contacting a "live" wire may make exposed metal parts of the power tool "live" and could give the operator an electric shock.
- **Check the ground (earth) connection of the electrical plug.**
- **If you detect a leak in any part of the water supply system, shut the machine down immediately and repair the fault. Water pressure should not exceed 70 psi (4 bar).**
- **Take care not to damage gas, water, power and other conduits in the area of the drilling operation.** Drain or shut off these conduits as required.
- **Block off the working area and place warning signs on both sides of the wall when drilling through from one side to the other.**
- **Take appropriate precautions to ensure that, in the event of a drilling core dropping out, no personal injury or material damage will result.**
- **When drilling hollow components, check the flow route of the cooling water in order to prevent damage.**
- **WARNING: Pull the plug out of the socket before making device settings or changing accessories.** Many accidents are caused by accidental starting of power tools.
- **When mounting the stand, fix the base to a firm, level, surface or wall.** The power tool cannot be guided evenly and safely if the base can slip or shake.
- **This diamond core drill cannot be used for overhead drilling unless special water control equipment is used.**

**WARNING: Hazardous situation due to broken parts: Always check core bits before using. Deformed or damaged drill core bits must not be used;**

**WARNING: Use of non-recommended cutting tools can lead to injuries due to the loss of control. Only use drill core bits designed for this machine only. Follow the minimum and maximum diameter given on**

the specifications page and do not exceed the length of the core bits beyond the maximum allowed by the drill stand.

**WARNING: Incorrect clamping and positioning of the drill core bit may lead to dangerous situations by broken and ejected parts of the drill core bit. Core bits must be assembled correctly. Follow the instructions below under "Fastening the Core Bit"**

**WARNING: It is necessary to always wear suitable personal protective equipment, including:**

- **Hearing protection, to reduce the risk of induced hearing loss,**
- **Gloves, when handling core bits or rough materials, to reduce injuries by sharp edges,**
- **Safety glasses, to prevent injuries by flying particles,**
- **Non-slipping footwear, to prevent injuries caused by slippery surfaces;**

**WARNING: A wrongly assembled machine may cause a hazardous situation. Follow the instructions provided with the drill stand on how to fix the machine into the stand and fixing to the material to be drilled; See also the instructions below under "Mounting to a Drilling Stand"**

## **INTRODUCTION**

This machine is for the intended purpose of diamond core drilling of concrete, masonry, stone and similar materials. It must always be mounted on a drilling stand to operate. This machine is for professional use only, and only trained personnel may operate this machine. All other uses which are not for the intended purpose are prohibited.

It is equipped with a water feed system which is required for the diamond core drilling process. This water also serves to cool the motor.

The high frequency motor with integrated power converter runs on single phase supply and features a built-in RCD interrupter (residual current device). The rotation speed is electronically adjustable to suit various core bit diameters. The motor has electronics for soft start, overload protection and thermal (overheating) protection. There is an overload warning to alert the operator of load and overload conditions. Its gearbox is equipped with a mechanical safety clutch.

Additional features include spindle threading function to more easily install the bit, and rebar assist function to improve performance when embedded steel is encountered.

## **ELECTRICAL CONNECTION**

The network voltage must conform to the voltage indicated on the tool name plate.

Under no circumstances should the tool be used when the power supply cable is damaged. A damaged cable must be replaced immediately by an authorized Customer Service Center. Do not try to repair the damaged cable yourself. The use of damaged power cables can lead to an electric shock.

## LIST OF CONTENTS

- Diamond core drilling machine.
- Water feed assembly
- Wrench

## OPERATING INSTRUCTIONS

### 1) MOUNTING THE CORE BIT

**CAUTION: Ensure that the threads of the spindle and the core bit match. Attempting to mount mismatched threads will result in damage to both threads.**

The spindle thread is 1-1/4" UNC. Ensure both the core bit and the machine spindle are clean. Any debris could cause excessive run-out of the mounted core bit. Excessive run-out can cause premature failure of the core bit and/or a safety hazard.

Tighten the bit to the spindle using two wrenches.

### BIT THREADING FUNCTION

With heavy, large diameter bits, the Bit Threading function can assist in threading the bit onto the spindle. Align the spindle with the bit, and with the motor OFF, press the Bit Threading Button on the control panel. (This is a latching switch, so press once to activate, and once to stop.) A few moments after pressing the button, "CH" will be displayed on the information screen, and the spindle will continuously rotate slowly clockwise. When threading is completed, press the Bit Threading Button again to stop. Final tighten the bit with two wrenches.

### Choosing the correct core bit for the job

Ensure that the bit you are using is suitable for the material you are drilling. We recommend always using wet-type (sintered) bits with this machine.

### 2) WATER SUPPLY

Water is a basic requirement for diamond core drilling. The water serves as a coolant to avoid the working surface at the tip of the bit from overheating. In addition, the water is necessary to cool the motor and controller. Never use this machine without water feed.

To connect the water supply. Attach the quick-release water coupling to a water hose.

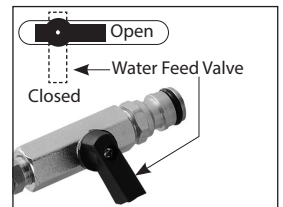

## THE WATER FEED ASSEMBLY

The water feed assembly may be mounted on either side of the motor unit as desired. To switch sides, exchange the plug on the unused side with the water feed assembly. Use about 3 turns of thread seal tape to seal each part when assembling.

**WARNING: Check all connections of the water feed system to ensure there are no leaks. Inspect hoses and other critical parts which could deteriorate.**

**WARNING: The maximum water pressure should not exceed 70 psi (4 bar).**

**CAUTION: Only use clean water! Contaminated water will clog the motor's cooling jacket, necessitating complete disassembly of the motor to rectify.**

**CAUTION: Ensure that the Water Inlet Strainer is in good condition. Never remove the strainer! The strainer is essential to help keep contaminants out of the motor's cooling jacket.**

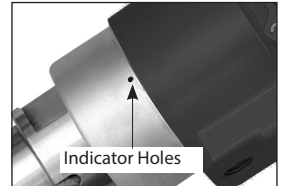

**CAUTION: Have the tool repaired immediately if cooling water is clogged in the motor. Do not operate the tool if water can not flow through the motor and exit from the spindle, or if there is an obviously reduced/restricted amount of water flowing through the motor.**

**CAUTION: There is a small indicator hole on the water feed collar. If this hole leaks water, it indicates that the water seals are worn out. Replace them immediately.**

**CAUTION: Never use this machine without water feed. Running dry will overheat its motor and destroy its water seals.**

Use a water collector with a wet vacuum to collect cooling water if nearby objects could be damaged by water.

**CAUTION: Never allow water to freeze inside the motor.** If working in temperatures near 0°C, always blow out all water from inside the motor's cooling passages with compressed air after use.

## 3) SELECTING SPEEDS

Speeds are selected by pressing the UP and DOWN Diameter Selector Buttons on the control panel. There are 17 speed settings, corresponding to diameters 102 mm up to 500 mm (or 4" up to 20"). The Information Screen will indicate the recommended bit diameter for each selection. Speeds can be selected with the motor at rest, or when it is running. The two smallest diameter settings will have reduced torque (to avoid over-stressing the smaller bits). The motor keeps the most recently selected speed setting in its memory until the next time the motor is plugged in.

**NOTE: The recommended speeds are based on average conditions. If the concrete is especially hard, or**



**with heavy reinforcement, a slower speed may be required.**

\* If a **slower** speed is required, select a **larger** diameter setting than the actual bit.

\* If a **faster** speed is required, then select a **smaller** diameter setting than the actual bit.

## CHANGING BETWEEN mm and inch DISPLAY

With the motor plugged in, but not running, press and hold the Rebar Assist Button continuously for 4 seconds. The displayed units will change. To change back, repeat the process.

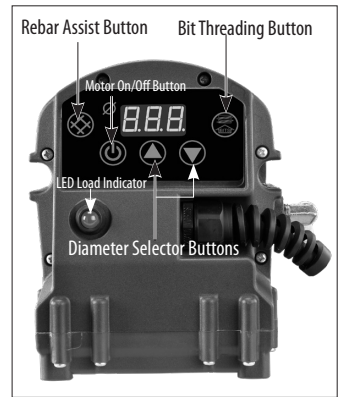

## ELECTRONIC SPEED SETTINGS WITH CORRESPONDING RATED LOAD SPEEDS

Speed Setting Ø (mm)	Rated Load rpm	Speed Setting Ø (inches)	Rated Load rpm
500 mm	220 /min	20"	220 /min
450 mm	225 /min	18"	225 /min
400 mm	230 /min	16"	230 /min
350 mm	240 /min	14"	240 /min
325 mm	253 /min	13"	253 /min
300 mm	274 /min	12"	274 /min
275 mm	300 /min	11"	300 /min
250 mm	329 /min	10"	329 /min
202 mm	407 /min	8"	407 /min
182 mm	451 /min	7"	451 /min
172 mm	478 /min	6.5"	478 /min
162 mm	507 /min	6.25"	507 /min
152 mm	525 /min	6"	525 /min
142 mm	532 /min	5.5"	532 /min
127 mm	540 /min	5"	540 /min
122 mm	540 /min*	4.5"	540 /min*
102 mm	540 /min*	4"	540 /min*

(\* Torque reduced to protect bit)

## 4) MOUNTING TO A DRILLING STAND (NOT INCLUDED)

**Warning: Do not attempt to mount to a rig that does not have a perfectly fitting mounting system.**

This motor has 2 mounting possibilities. It can use an AGP system six-bolt mounting plate, or just use the lower 4 bolt holes, which are in a standard bolt hole pattern for attaching most types of 4-bolt mounting plates. Use the mounting plate suitable for the drill stand you are using to mount your drill motor to your stand. (If there is not enough clearance between the motor's electronics box and the drill stand, use the optional 40mm

extension spacer kit, and place it between your stand's mounting plate and the motor). Tighten the four bolts evenly to 12Nm.

To mount to the stand, loosen the cradle lock bolt and place the mounting spacer squarely in the cradle. Then tighten the cradle lock bolt firmly to 17Nm.

The drill stand may be anchored to the work piece in one of three ways, with a mechanical anchor, with a vacuum base, or with a jack screw. (Follow the instructions provided with the drill stand.)

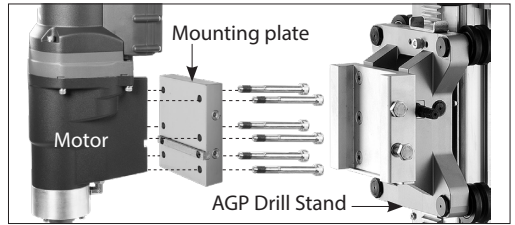

## TO INSTALL THE DRILL STAND

1. Measure the distance from the center of the intended cut to the location of the mounting slot in the base. Follow the concrete anchor manufacturer's instructions to install. Using an appropriate tool such as a rotary hammer, drill a correct sized hole to fit the anchor. Then drive in the anchor to below flush.

2. Move the base into position and screw in the anchor bolt, washer and nut, leaving it finger tight for the moment.

3. Using a spirit level, adjust the four leveling bolts to achieve a good level positioning, then fully tighten the center anchor bolt. The entire stand must be mounted solidly.

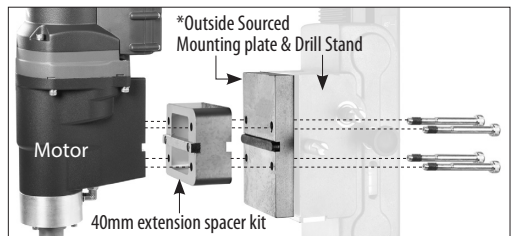

**WARNING: Never attempt to drill unless the stand is fixed securely beyond any doubt.**

## 5) TURNING THE TOOL ON AND OFF

When the motor is first plugged in, the Information Screen will briefly display "000", followed by the electronics board version code. Shortly after, the most recently selected core bit diameter is displayed. The LED Load Indicator will flash green continuously, showing that the motor is energized and ready to run.

To start the motor, press the ON/OFF button.

To stop the motor, press the ON/OFF button again.

## HOLE STARTING FUNCTION

Whenever the motor is first switched on, for the first 4 seconds, it will run at 50% rotation speed. This is to aid in starting the hole. After 4 seconds, it will increase to 100% of the selected rotation speed.

## 6) OVERLOAD PROTECTION AND OVERHEAT PROTECTION

### LED LOAD INDICATOR

The LED Load Indicator will flash green whenever the machine is plugged in (but not running), to indicate that the machine is energized.

It will glow solid green when it is running with the load within the normal range.

### OVERLOAD WARNING SYSTEM

When the load approaches overload conditions, the LED Load Indicator will flash red, and the motor may begin to slow down.

### OVERLOAD

If the excessive load is sustained too long, the motor will stop, and the LED Load Indicator will glow solid red. Also, the "E01" error code will be displayed on the Information Screen. In this case, the motor must be restarted.

### OVERHEAT THERMAL PROTECTION

If the temperature of the motor gets too high, the thermal protection system will stop the motor, and the LED Load Indicator will glow solid red.

The "E02" or "E08" error code will be displayed on the Information Screen. Allow cooling water to flow through the motor to bring the temperature down before continuing.

**CAUTION: The motor will be damaged if it is repeatedly overloaded or overheated.**

Always cool the motor by allowing cooling water to run through the motor for a few minutes whenever it stops from either overheat or overload.

### REBOOTING THE SYSTEM

In cases where the tool becomes unresponsive to any button inputs on the control panel, the system must be rebooted. This occasionally occurs when there is heavy vibration or overload. To reboot, simply unplug the power supply cord and wait for about 60 seconds (to allow the capacitors to discharge), then plug back in to restart the system.

## 7) SAFETY CLUTCH

This machine is equipped with a mechanical clutch to protect the operator and machine from excessive

torque forces. When the preset maximum torque level is reached, the clutch will slip. After the clutch slips many times, it will become worn and slip at lower and lower torque levels. When this happens, it must be serviced by an authorized service provider. The recommended torque of the clutch nut is 21 Nm.

**CAUTION: Always ease off the load immediately whenever the clutch slips. Do not allow the clutch to continue slipping or it will wear out prematurely.**

## DRILLING INSTRUCTIONS

1. Open the water valve and very gently begin the cut. Use very light feed pressure to prevent the bit from wandering until the bit is fully penetrated into the cut.
2. Make adjustments to the water feed as needed. The water leaving the cut should be a solid colored slurry with about the consistency of milk.
3. Once in the cut, use steady feed pressure.
4. When the bit is about to break through, reduce feed pressure.

## REBAR ASSIST BUTTON

When embedded steel reinforcing is encountered, press the Rebar Assist Button. "Lo" will be displayed on the Information Screen, and the rotational speed will be reduced. Reduce your feed pressure by about 1/3 and let the bit go at its own pace. (If there is too much vibration, the bit can be damaged). As soon as the rebar is passed, press the Rebar Assist Button again to return to normal operation.

## ABOUT DIAMOND BITS

The diamond impregnated segments in a wet type (sintered) diamond core bit operate on a principle of controlled erosion. The bond matrix holding the diamonds is continually worn away by abrasion with the work piece, exposing the harder diamonds to stand proud from the bond matrix. Without adequate water, the bit would overheat and be destroyed.

With too much water and not enough feed pressure, there would not be adequate erosion of the bond matrix and the bit becomes dull. This is called glazing. If the bit seems to refuse to cut anymore, it is glazed. **See below: "SHARPENING A GLAZED BIT"**

Don't feed too gently or the diamond segments will become glazed. Keep the bit steadily working. If the cut is very deep, the core plug may be obstructing the flow of cooling water. In this case, stop drilling, and chisel out the core plug before continuing.

**CAUTION: If the bit gets stuck, do not try to rock it loose by turning the switch on and off. That is hazardous and could damage the motor. Rather, unplug the machine and use a wrench on the bit mounting to work it loose.**

**CAUTION: Drilling operations are very stressful to the motor and at the end of the cut, the motor**

**temperature will be very hot, always allow cooling water to flow through the motor until the temperature returns to normal.**

## **RESHARPENING A GLAZED BIT**

If the bit becomes glazed, sharpen by dressing with an appropriate alumina oxide or silicon carbide dressing stone. Simply drill into the stone as many times as necessary to restore the bit's cutting performance.

## **VIBRATION TROUBLESHOOTING**

If vibration occurs and it is not caused by embedded steel, stop drilling to find the cause and remedy.

**CAUTION: Do not operate with vibration or there will be serious hazard and the diamond core bit will be destroyed.**

**Vibration is usually caused by:**

1. A bit with too much runout  
**SOLUTION:** Replace bit.
2. A bit with diamond segments broken off  
**SOLUTION:** Repair or replace bit.
3. Shifted base or loose gibs  
**SOLUTION:** Retighten mountings or adjust gibs as needed.

## **MAINTENANCE**

Always check for a damaged power supply cable, check for loose fasteners and always keep alert for unusual noises and vibration when operating.

**WARNING: Never operate a damaged machine. Always tag a damaged machine and take it out of service until repairs can be made.**

**CAUTION: Never allow water to freeze inside the motor. If working in temperatures near 0°C, always blow out all water from inside the motor's cooling passages with compressed air after use.**

**CAUTION: This machine is equipped with an oil bath gearbox. To avoid leakage of lubricating oil, whenever the gearbox is opened, the o-ring seal must be replaced with a new one.**

**CAUTION: If the gear oil is found to be leaking out, have the machine repaired by a qualified service center immediately. Running without sufficient oil will lead to certain damage of the gearbox.**

## CLEANING LIMESCALE

Over time, limescale deposits (mainly calcium carbonate) can build up in the motor's cooling jacket, resulting in less and less water flow as the limescale increases. If it is apparent that water flow through the motor is reduced, descaling is necessary.

To descale the motor, prepare a 5% citric acid descaling solution. To make a 5% solution, add 50 g (30 ml) of pure citric acid powder for every liter of water (16 tablespoons of powder to every gallon of water). Using a portable pressurized water supply tank, pump the descaling solution into the motor and allow it to soak for 15 minutes or so. After soaking, allow the remaining solution to circulate through the motor and collect in a bucket. Repeat until the solution flows freely. Once descaled, allow fresh water to flow through the motor for a few minutes to neutralize any acidity from the descaling solution.

Maintenance which should be performed by an authorized service center, include the following:

- Replace water seals as needed.
- Change the gear oil about every 100 hours of operation
- Replace the clutch discs and spring as needed.

**If the replacement of the power supply cord is necessary, this has to be done by the manufacturer or their agent in order to avoid a safety hazard.**

**WARNING: All repairs must be entrusted to an authorized service center.** Incorrectly performed repairs could lead to injury or death.

Do not throw electric power tools into the household waste! In accordance with the European Directive 2002/96/EG on Waste Electrical and Electronic Equipment and transposition into national law, used electric power tools must be collected separately and recycled in an environmentally friendly manner.

## ERROR CODES

Error Code	Condition	Corrective Action	Further Action
E01	Hardware current overload Motor tries to start and does not rotate for >1 second UVW motor terminals connected out of phase	Press On/Off switch to restart	If problem persists, bring to service center
E02	Controller temperature too high	Automatically clears when the temperature returns to normal	Keep cooling water flowing
E03	Voltage too low	Automatically clears when voltage returns to normal	Check electrical supply
E04	Voltage too high	Automatically clears when voltage returns to normal	Check electrical supply
E05	Voltage too high during braking	Press On/Off switch to restart	
E06	Current leakage sensor failure	Unplug / re-plug	If problem persists, bring to service center

<b>E07</b>	Angle sensor error	Unplug / re-plug	If problem persists, bring to service center to have sensor checked
<b>E08</b>	Motor temperature too high	Automatically clears when the temperature returns to normal	Keep cooling water flowing
<b>E11</b>	Current leakage detected	Unplug / re-plug	If problem persists, bring to service center
<b>E16</b>	Temperature sensor open circuit	Replace Sensor (service center)	
<b>E17</b>	Temperature sensor short circuit	Replace Sensor (service center)	
<b>E30</b>	Motor angular position not synchronized	Automatically clears after motor synch positioning (service center)	
<b>888</b>	Failed communication between the information screen and controller	Automatically clears when it receives controller signal	If problem persists, bring to service center

## **MOTOR ANGULAR POSITION SYNCHRONIZATION PROCEDURE**

If the motor has been disassembled, or if the E30 error code appears, the following steps are required:

1. Plug the tool in and allow it to go through its boot up sequence; you will see "000", then the code for the electronics board version, and finally the diameter setting.
2. DO NOT press the "ON" button. Instead, press, and hold down, both the "UP" and "DOWN" buttons simultaneously until you see "P0" and then "P1". The motor will start spinning.
3. You can now release the "UP" and "DOWN" buttons. "P1" will continue to be displayed and the motor will spin for a short time.
4. (If you see "P2" displayed, it means the synchronization was unsuccessful, so repeat steps 1-3.)
5. If you see "P3" displayed, press, and hold down, both the "UP" and "DOWN" buttons simultaneously until you see the diameter setting displayed as normal. Synchronization is now complete.

# Exploded View

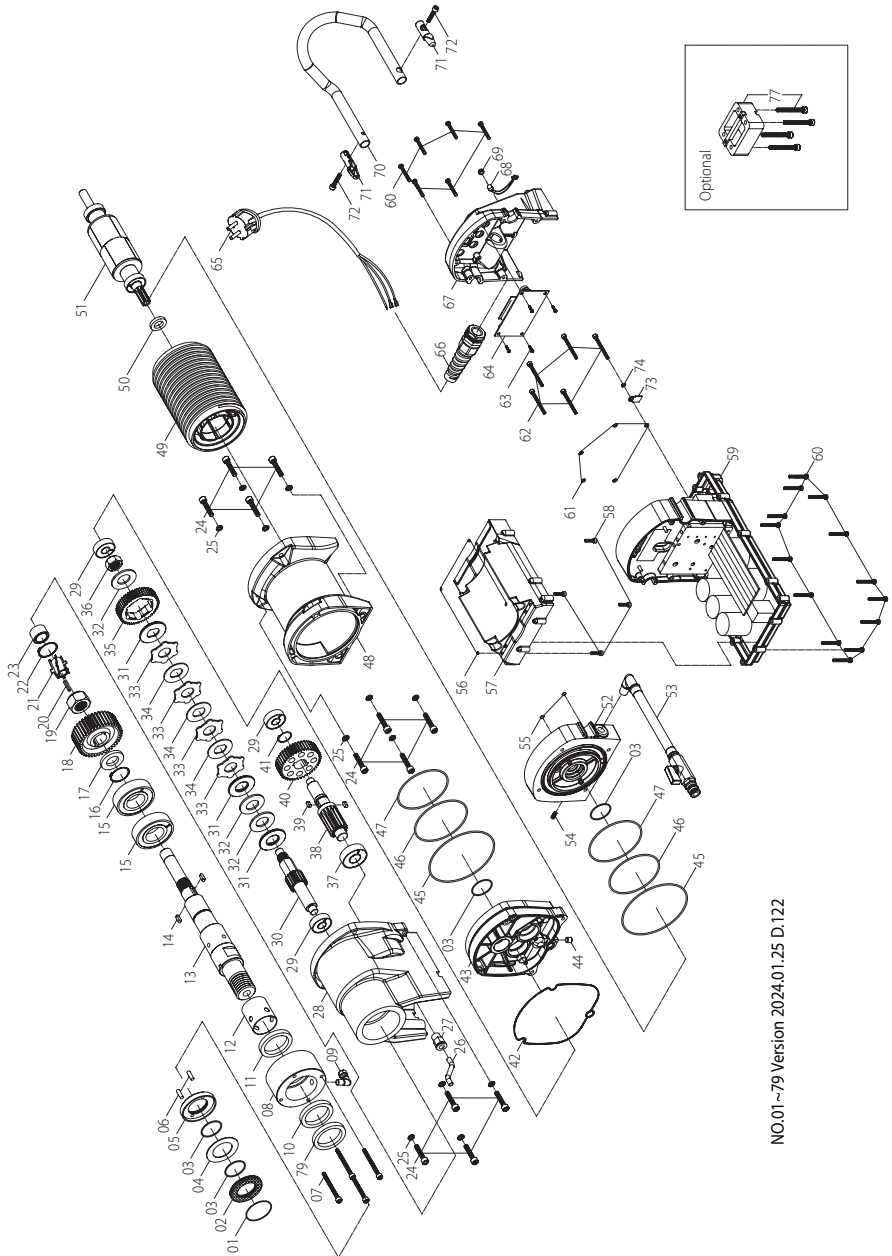

NO.01~79 Version 2024.01.25 D.122



## Parts List

NO.	Parts Name	Q'ty	NO.	Parts Name	Q'ty
1	O-RING (Ø45x1.5)	1	39	PARALLEL KEY (6x6x15)	2
2	ANTI-SEIZE RING	1	40	LAY GEAR (M1.5x40T)	1
3	O-RING (Ø32x1.5)	4	41	EXTERNAL CIRCLIP (S-20)	1
4	THRUST RING (3252)	1	42	GEAR CASE GASKET	1
5	ANTI-SEIZE CUP	1	43	GEAR PLATE	1
6	DOWEL PIN (Ø4x11.8)	2	44	SOCKET SET SCREW (M8x7xP1.25)	1
7	SOCKET CAP SCREW (M5-0.8 x 55)	4	45	O-RING (Ø105xØ109x2)	2
8	WATER FEED HOUSING	1	46	O-RING (Ø84xØ88x2)	2
9	ELBOW FITTING (PT1/4" x 3/8"U)	1	47	O-RING (Ø76xØ80x2)	2
10	OIL SEAL (Ø40xØ52x7)	1	48	MOTOR HOUSING	1
11	OIL SEAL (Ø40xØ50x7)	1	49	STATOR ASSEMBLY	1
12	STAINLESS BUSHING	1	50	OIL SEAL (Ø15xØ25.5x4.6)	1
13	OUTPUT SPINDLE	1	51	ARMATURE ASSY.	1
14	PARALLEL KEY (6x6x20)	2	52	MOTOR END CASTING	1
15	BALL BEARING (6206)	2	53	WATER FEED CONNECTOR KIT	1
16	EXTERNAL CIRCLIP (S-30)	1	54	SOCKET SET SCREW-SUS (PT1/4")	1
17	OIL SEAL (Ø30xØ55x7)	1	55	O-RING (Ø7.8x1.3)	2
18	OUTPUT GEAR	1	56	O-RING (Ø4.5x1)	4
19	NYLOOK NUT (M20xP1.5)	1	57	ELECTRONICS COVER	1
20	PARALLEL KEY (4x4x30)	1	58	SOCKET CAP SCREW (M4-0.7 x 16)	4
21	OIL IMPELLER	1	59	ELECTRONICS UNIT	1
22	EXTERNAL CIRCLIP (S-18)	1	60	PANHEAD TAPPING SCREW (M4x30)	20
23	NEEDLE BEARING (TA1815)	1	61	FLAT WASHER (Ø4xØ10x1)	5
24	SOCKET CAP SCREW (M6-1.0 x 30)	12	62	SOCKET CAP SCREW (M4-0.7 x 40)	5
25	SPRING WASHER (M6)	12	63	PANHEAD TAPPING SCREW (M4x8)	4
26	FLEXIBLE COOLANT NOZZLE (Ø6.4xØ10x0.12M)	1	64	LCD DISPLAY	1
27	FITTING (1/4" M x Ø10)	1	65	POWER SUPPLY CABLE (VDE-1.5x3Cx3.5M-H07RNF)	1
28	GEAR HOUSING	1	66	STRAIN RELIEF GLAND	1
29	BALL BEARING (6201)	3	67	TAIL COVER (GRAY-RAL7016)	1
30	CLUTCH PINION(M1.5x20T)	1	68	LED OVERLOAD LAMP (110V&220V)	1
31	PRESSURE DISC (Ø20.1xØ43x3)	3	69	PROTECTION FRAME	1
32	BELLEVILLE SPRING	3	70	HANDLE RETAINER	1
33	CLUTCH BRASS DISC (Ø20.1xØ41x2)	4	71	HANDLE RETAINER	2
34	CLUTCH STEEL PLATE	3	72	SOCKET CAP SCREW (M5-0.8 x 20)	2
35	INPUT GEAR (M1.25x51T)	1	73	EARTHING MARKING	1
36	HEX NUT (M16)	1	74	EXTERNAL STAR WASHER (M5)	1
37	BALL BEARING (6203)	1	77	EXTENSION SPACER	1
38	COUNTERSHAFT (M1.75x14T)	1	79	OIL SEAL (Ø40xØ55x7)	1

# WIRING

