

AGP[®]

Stone Cutting Circular Saw

SCS8



Instruction Manual

CE CB



SPECIFICATIONS

Model	SCS8
Power Input	1800 W (220 V), 1680 W (110 V)
Voltage, Frequency	220-240 V ~450-60 Hz or 110-120 V ~50-60 Hz
No Load Speed (n ₀)	6000 min ⁻¹
Arbor	22.23 mm (7/8")
Blade diameter	200 mm (8") or 180 mm (7")
Cutting Depth (0°)	70 mm (65 mm on rail) 200 mm blade
	60 mm (55 mm on rail) 180 mm blade
Cutting Depth (45°)	52 mm (47 mm on rail) 200 mm blade
	45 mm (40 mm on rail) 180 mm blade
Overload Protection	With
Insulation Class	Class I with PRCD / GFCI
Dimensions (LxWxH)	510 x 313 x 198 mm
Weight	5.7 kg (12.5 lb)

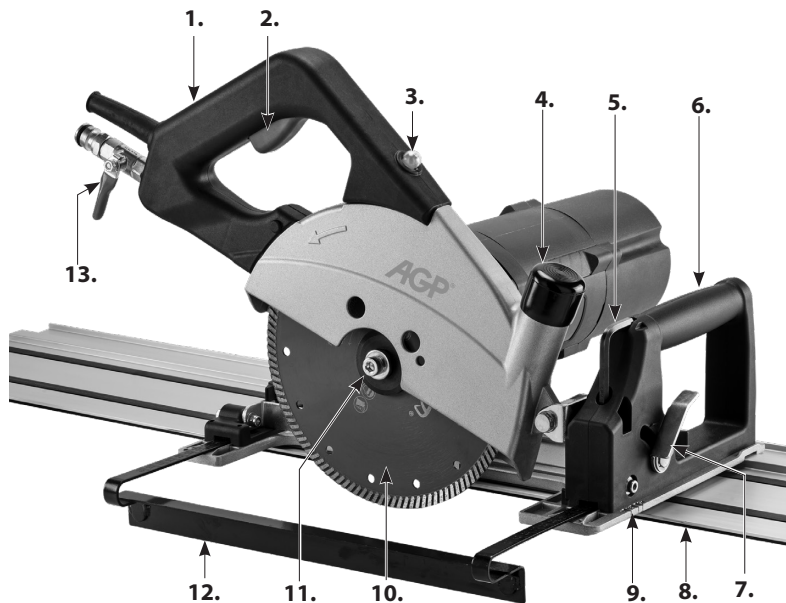

1. Main Handle
2. Trigger Switch
3. LED Load Indicator
4. Dust Port Cap
5. L-Hex Wrench
6. Front Handle
7. Bevel Lock Lever
8. Guide Rail (optional)
9. Sighting Notches
10. Diamond Blade (optional)
11. Arbor Screw
12. Parallel Guide
13. Water Feed Valve
14. Parallel Guide Lock Knobs
15. Depth Lock Lever
16. Bevel Scale
17. Arbor Lock
18. Depth Scale
19. Trigger Release Button

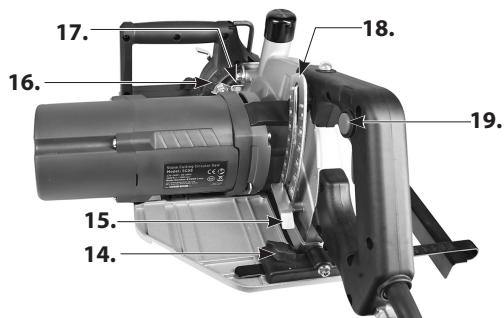

GENERAL SAFETY INSTRUCTIONS



WARNING! Read all safety warnings and all instructions. Failure to follow the warnings and instructions may result in electric shock, fire and/or serious injury.

Save all warnings and instructions for future reference. The term “power tool” in the warnings refers to your mains operated (corded) power tool or battery-operated (cordless) power tool.

1) WORK AREA SAFETY

- a. **Keep work area clean and well lit.** Cluttered or dark areas invite accidents.
- b. **Do not operate power tools in explosive atmospheres, such as in the presence of flammable liquids, gases or dust.** Power tools create sparks which may ignite the dust or fumes.
- c. **Keep children and bystanders away while operating a power tool.** Distractions can cause you to lose control.
- d. **Never leave the electric power tool unattended.** Only leave the machine when the tool in use has come to a complete standstill.

2) ELECTRICAL SAFETY

- a. **Power tool plugs must match the outlet. Never modify the plug in any way. Do not use any adapter plugs with earthed (grounded) power tools.**
Unmodified plugs and matching outlets will reduce risk of electric shock.
- b. **Avoid body contact with earthed or grounded surfaces such as pipes, radiators, ranges and refrigerators.** There is an increased risk of electric shock if your body is earthed or grounded.
- c. **Do not expose power tools to rain or wet conditions.** Water entering a power tool will increase the risk of electric shock.
- d. **Do not abuse the cord. Never use the cord for carrying, pulling or unplugging the power tool. Keep cord away from heat, oil, sharp edges or moving parts.** Damaged or entangled cords increase the risk of electric shock.
- e. **When operating a power tool outdoors, use an extension cord suitable for outdoor use.** Use of a cord suitable for outdoor use reduces the risk of electric shock.
- f. **If operating a power tool in a damp location is unavoidable, use an earth leakage circuit breaker.** Use of an earth leakage circuit breaker reduces the risk of electric shock.

3) PERSONAL SAFETY

- a. **Stay alert, watch what you are doing and use common sense when operating a power tool. Do not use a power tool while you are tired or under the influence of drugs, alcohol or medication.** A moment of inattention while operating power tools may result in serious personal injury.
- b. **Use personal protective equipment. Always wear eye protection.** Protective equipment such as dust mask, non-skid safety shoes, hard hat, or hearing protection used for appropriate conditions will reduce personal injuries.
- c. **Prevent unintentional starting. Ensure the switch is in the off-position before connecting to power source and/or battery pack, picking up or carrying the tool.** Carrying power tools with your finger on the switch or energising power tools that have the switch on invites accidents.

- d. **Remove any adjusting key or wrench before turning the power tool on.** A wrench or a key left attached to a rotating part of the power tool may result in personal injury.
- e. **Do not overreach. Keep proper footing and balance at all times.** This enables better control of the power tool in unexpected situations.
- f. **Dress properly. Do not wear loose clothing or jewelry. Keep your hair, clothing and gloves away from moving parts.** Loose clothes, jewelry or long hair can be caught in moving parts.
- g. **If devices are provided for the connection of dust extraction and collection facilities, ensure these are connected and properly used.** Use of dust collection can reduce dust-related hazards.
- h. **Do not let familiarity gained from frequent use of tools allow you to become complacent and ignore tool safety principles.** A careless action can cause severe injury within a fraction of a second.

4) POWER TOOL USE AND CARE

- a. **Do not force the power tool. Use the correct power tool for your application.** The correct power tool will do the job better and safer at the rate for which it was designed.
- b. **Do not use the power tool if the switch does not turn it on and off.** Any power tool that cannot be controlled with the switch is dangerous and must be repaired.
- c. **Disconnect the plug from the power source and/or the battery pack from the power tool before making any adjustments, changing accessories, or storing power tools.** Such preventive safety measures reduce the risk of starting the power tool accidentally.
- d. **Store idle power tools out of the reach of children and do not allow persons unfamiliar with the power tool or these instructions to operate the power tool.** Power tools are dangerous in the hands of untrained users.
- e. **Maintain power tools. Check for misalignment or binding of moving parts, breakage of parts and any other condition that may affect the power tool's operation. If damaged, have the power tool repaired before use.** Many accidents are caused by poorly maintained power tools.
- f. **Keep cutting tools sharp and clean.** Properly maintained cutting tools with sharp cutting edges are less likely to bind and are easier to control.
- g. **Use the power tool, accessories and tool bits etc., in accordance with these instructions, taking into account the working conditions and the work to be performed.** Use of the power tool for operations different from those intended could result in a hazardous situation.
- h. **Keep handles and grasping surfaces dry, clean and free from oil and grease.** Slippery handles and grasping surfaces do not allow for safe handling and control of the tool in unexpected situations.

5) SERVICE

Have your power tool serviced by a qualified repair person using only identical replacement parts. This will ensure that the safety of the power tool is maintained.

Symbols used in this manual

V.....volts

A.....amperes

Hz.....hertz

W.....watt

~.....alternating current

n_0no load speed

min^{-1}revolutions or reciprocation
per minute



.....warning of general danger



.....with electrical earth



.....read these instructions



.....always wear eye protection



.....always wear a dust mask.



.....always wear hearing protection



.....wear safety-approved hard hat



.....Keep hands clear – pinching hazard.



.....DANGER! Keep hands away from cutting area and the blade.



.....rotating parts - entanglement hazard. Keep hands, loose clothing and long hair away from moving parts



.....do not dispose of electric tools, accessories and packaging together with household waste material

SPECIFIC SAFETY RULES

- 1. Keep hands away from cutting area and blade at all times! Keep your second hand on an auxiliary handle.** If both hands are holding the saw, they cannot be cut by the blade.
- 2. Do not reach underneath the work.**
- 3. Hold tool by insulated gripping surfaces when performing an operation where the cutting tools may contact hidden wiring or its own cord.** Contact with a "live" wire will make exposed metal parts of the tool "live" and shock the operator.
- 4. Always use blades with correct size and shape arbor holes.** Blades that do not match the mounting hardware of the saw will run eccentrically, causing loss of control.
- 5. Never use damaged or incorrect arbor flanges or bolts.** The arbor flanges and bolt were specially designed for your saw, for best performance and safety of operation.
- 6. Maintain a firm grip on the saw and position your body and arm in a way that allows you to resist KICKBACK forces.** KICKBACK forces can be controlled by the operator, if proper precautions are taken.
- 7. Do not use a dull or damaged blade.**
- 8. Use only recommended blades,** rated at the machine's maximum rated RPM or higher with correct arbor hole.
- 9. Tighten blade retaining bolt** and all clamps before operating.
- 10. Check the inside surfaces** of the arbor flanges as well as the sides of the blade for freedom from any foreign matter.
- 11. Check the blade** for cracks or other damage before operation. Replace cracked or damaged blade immediately. Carry out a test run without load for at least 30 seconds before use.
- 12. Never start the tool** with the workpiece against the blade.
- 13. Allow the motor to achieve full speed** before cutting.
- 14. Important: After completing the cut,** release power switch and wait for coasting blade to stop

completely before putting the saw down

15. **Never operate** the tool in an area with flammable solids, liquids, or gases. Sparks from the commutator/ carbon brushes could cause a fire or explosion.
16. **There are certain applications for which this tool was designed.** The manufacturer strongly recommends that this tool NOT be modified and/or used for any application other than for which it was designed. If you have any questions relative to its application DO NOT use the tool until you have written the manufacturer and have been advised.
17. **Only use the machine for cutting in stone, concrete or masonry.**
18. **Use the auxiliary handles supplied with the tool.** Loss of control can cause personal injury.
19. **Use a residual current device (PRCD) (not included) to protect from current surges.**
20. **Keep power supply cord clear from the working range of the machine.** Always lead the cable away behind you.
21. **Immediately switch off the machine if unusual vibrations or if other malfunctions occur.** Check the machine in order to find out the cause.
22. **Only use and store diamond blades according to the Manufacturer's instructions.**
23. **Pay attention to the dimensions of the blades.** The diameter of the center bore must engage the arbor without play. If not use any necessary reduction pieces or adapters (supplied with the blade) to ensure a proper fit.
24. **Take care to avoid hidden electric lines, gas and water pipes.** Check your working area, e.g. with a metal detector before commencing work.
25. **The dust that arises when working with this tool can be harmful to health.** Use a dust absorption system and wear a suitable dust protection mask and remove deposited dust with a vacuum cleaner.

ELECTRICAL CONNECTION

The network voltage must conform to the voltage indicated on the tool name plate. Under no circumstances should the tool be used when the power supply cable is damaged. A damaged cable must be replaced immediately by an authorized Customer Service Center. Do not try to repair the damaged cable yourself. The use of damaged power cables can lead to an electric shock.

INTENDED USE

This saw is designed exclusively for wet or dry cutting of stone, concrete and masonry. This machine should not be used for cutting other materials. The machine should not be converted or modified, e.g. for any other form of use, other than as specified in these operating instructions. The user shall be liable for damages and accidents due to incorrect use.

EXTENSION CABLE

If an extension cable is required, it must have a sufficient cross-section so as to prevent an excessive drop in voltage or overheating. An excessive drop in voltage reduces the output and can lead to failure of the motor. Never use two extension cables together. Instead, use one long one.

UNPACKING

Carefully remove the tool and all loose items from the shipping container. Retain all packing materials until after you have inspected and satisfactorily operated the machine.

NOTE: An appropriate diamond blade must be mounted to the machine before operating. Refer to the section of this manual: "INSTALLING THE BLADE"

CARTON CONTENTS

- * Stone Cutting Circular Saw Machine
- * Vacuum hose connector
- * Parallel guide
- * Quick-release water hose coupling
- * L-hex wrench

TO INSTALL THE BLADE

1. Remove any accumulated debris in the guards and around the arbor.
2. First mount the Inner Flange, then the blade, making sure the direction of rotation arrow of the blade and the arrow on the machine are in the same direction.
3. Mount the Outer Flange, Washer and Arbor Bolt.
4. Press the Arbor Lock and rotate the spindle until the Arbor Lock engages. Then tighten the Arbor Bolt using the L-Hex Wrench.

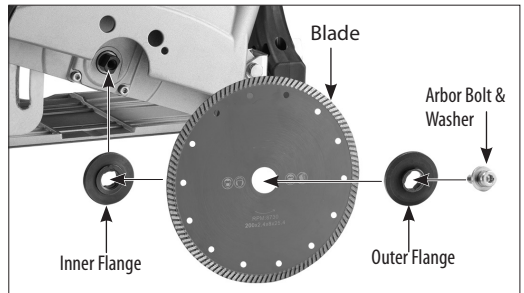

NOTE: Use blades that have an arbor bore which can fit, and that are rated for the machine's maximum rated speed or higher.

REMOVING THE BLADE

Removal is the opposite of installing the blade.

TO ADJUST THE BEVEL ANGLE

Loosen the Bevel Lock Lever by rotating it anticlockwise. Adjust to the desired bevel angle, observing the bevel scale. Tighten the Bevel Lock Lever.

NOTE: When the machine is cutting a bevel, its

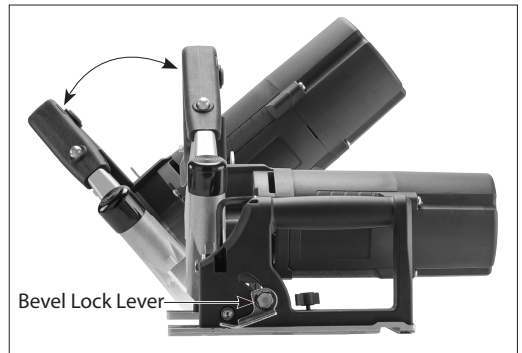

center of gravity will be inherently high and towards the right side: to counteract this, keep steady downforce on the left side handle. When pushing forwards use most of your thrust on the left handle, using the right handle to help guide only.

NOTE : The machine will be more stable if the depth of cut is set to its deepest position.

TO ADJUST THE DEPTH OF CUT

Loosen the Depth Lock Lever by rotating it anticlockwise and adjust the depth of cut to the desired amount. Then retighten the Lever. The scale on the left is for a 200 mm blade, and the one on the right is for a 180 mm blade.

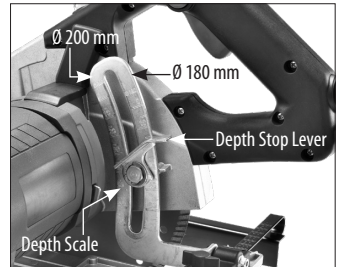

HOW TO USE THE SIGHTING NOTCH

To aid in free-hand cutting, a sighting notch is located at the front of the base plate. This mark corresponds to the blade's cutting line. There are marks for 0°, 30° & 45° bevels.

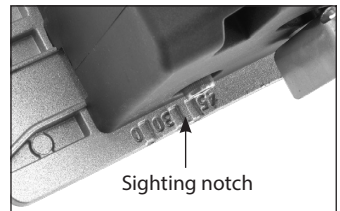

VACUUM DUST COLLECTION

There is a vacuum port provided on the blade cover to collect dust when operating. Simply attach the vacuum cleaner hose to the vacuum port. Keep the Cap in place when not in use.

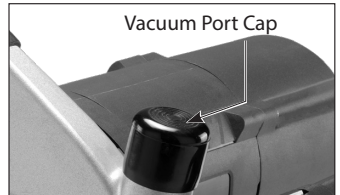

WATER FEED SYSTEM

WARNING: This machine is equipped with a Portable Residual Current Device (PRCD) also known as a Ground Fault Circuit Interrupter (GFCI). Always use this device whenever using the machine to reduce the risk of shock hazards. Always position the device PRCD as close as possible to the power source.

Test the PRCD device before each use. Press the "Test" button to test. Press the "Reset" button to energize the circuit to the machine.

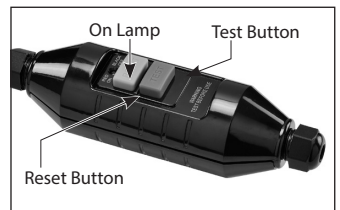

WARNING: Never use the machine without the PRCD fault-current safety switch supplied.

WARNING: Check all connections of the water feed system to ensure there are no leaks. Inspect hoses and other critical parts which could deteriorate.

WARNING: If you detect a leak in any part of the water supply

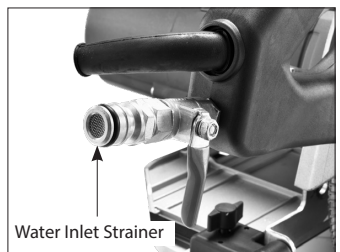

system, shut the machine down immediately and repair the fault.

WARNING: The maximum water pressure should not exceed 70 psi (4 bar).

The water feed system allows the machine to cut more effectively. Ensure that a PRCD interrupter unit is always used.

Mount the Quick Release Water Coupling to the water supply hose. Adjust the Water Valve for the desired amount of water flow.

WARNING: Great care must always be taken to avoid the risk of electrocution whenever using water. Never allow water to contact the electrical parts of the tool. Always use a PRCD Interrupter.

PARALLEL GUIDE

The Parallel Guide allows straight cuts to a desired distance from the edge.

To mount, insert the Parallel Guide into the slot in the Base Plate and tighten the Thumb Knobs at the desired position.

There is a scale indicating the width. The guide may be mounted upside down when not needed.

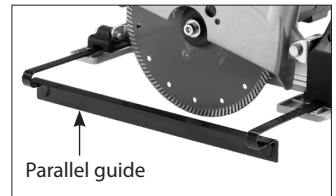

STARTING AND STOPPING TOOL

Make sure that the power circuit voltage is the same as that shown on the specification plate of the machine and that switch is "OFF" before connecting the tool to the power circuit

To switch on:

This machine is equipped with a "LOCK-OFF" switch. To press the switch, you must first press the release button. Then the trigger switch will be free to be pressed to start the machine.



To switch off:

Release the trigger switch to stop the machine. After the machine has been switched off, the blade will still rotate for a time, take care that parts of your body do not come into contact with the blade while it is still rotating !

OVERLOAD PROTECTION, OVERHEAT PROTECTION

Overload & Load Warning Lamp

When full load is reached, the load warning lamp will flash red. If full load is exceeded and sustained for too long, the motor will shut down and the load warning lamp will glow solid red. In this case, the motor must be first shut off and then restarted.



Thermal Protection

If the temperature of the motor gets too high, the thermal protection will shut the motor down. The switch must be first shut off and then restarted.

When this happens, do not immediately start cutting after restarting the motor. Always run the machine at no load for a few minutes to return to a normal operating temperature before continuing.

CAUTION: The motor will be damaged if it is repeatedly overloaded or overheated. Always cool the motor by running at no load for a few minutes whenever it stops from either overheat or overload.

SPEED STABILIZATION

This machine is equipped with an electronic speed stabilization system which maintains constant speed under load.

HOW TO USE THE TOOL

Support the work properly and to hold the saw firmly **WITH BOTH HANDS** to prevent loss of control which could cause personal injury.

OPERATION

1. Adjust the depth of cut.
2. Draw a cutting line before beginning cutting.
3. Place the machine in position on the workpiece.
4. While the blades are not yet in contact with the workpiece, press the lock button squeeze the trigger and allow the machine to reach full speed.
5. Holding firmly with both hands, slowly advance the machine until it makes contact with the workpiece. Begin moving forward along the line of cut Take care that the base remains firmly on the workpiece.

CAUTION: Take care not to cut in a curved line. This will likely damage the diamond blade causing a severe hazard.

6. When the cut is finished, allow the coasting blade to come to a full stop before setting down.

NOTE: Only operate the machine forwards relative to itself and never backwards. If you cut backwards there is the danger that the machine might be accelerated out of the cutting groove (recoil) and cause serious injury.

CAUTION: Keep the cord away from cutting area to prevent it from becoming entangled in the workpiece.

Do not force the cut. Let the saw do the cutting at the rate of speed permitted by the type of cut and workpiece.

SHARPENING DULL DIAMOND BLADES

If a lot of sparks are seen while cutting, this is a sign that the blade is becoming dull. To create better diamond exposure (sharpen), make several cuts in a special sharpening stone for diamond blades or alternately use calcareous sandstone.

MAINTENANCE

Every 50 hours of operation blow compressed air through the motor while running at no load to clean out accumulated dust. (If operating in especially dusty conditions, perform this operation more often.)

KEEP TOOL CLEAN

Periodically blow out all air passages with dry compressed air. All plastic parts should be cleaned with a soft damp cloth. NEVER use solvents to clean plastic parts. They could possibly dissolve or otherwise damage the material. Wear safety glasses while using compressed air.

THE CARBON BRUSHES

The carbon brushes are a normal wearing part and must be replaced when they reach their wear limit.

TO REPLACE

Remove the tail cover (4 screws) to gain access to the brushes. Withdraw the old brushes. Replace with new brushes (always replace as a pair) ensuring that they align properly and slide freely. Then replace the tail cover.

If the replacement of the power supply cord is necessary, this has to be done by the manufacturer or their agent in order to avoid a safety hazard.

WARNING: All repairs must be entrusted to an authorized service center. Incorrectly performed repairs could lead to injury or death.

EXPLODED VIEW

NO.01~84 Version 2023.12.08 D.122

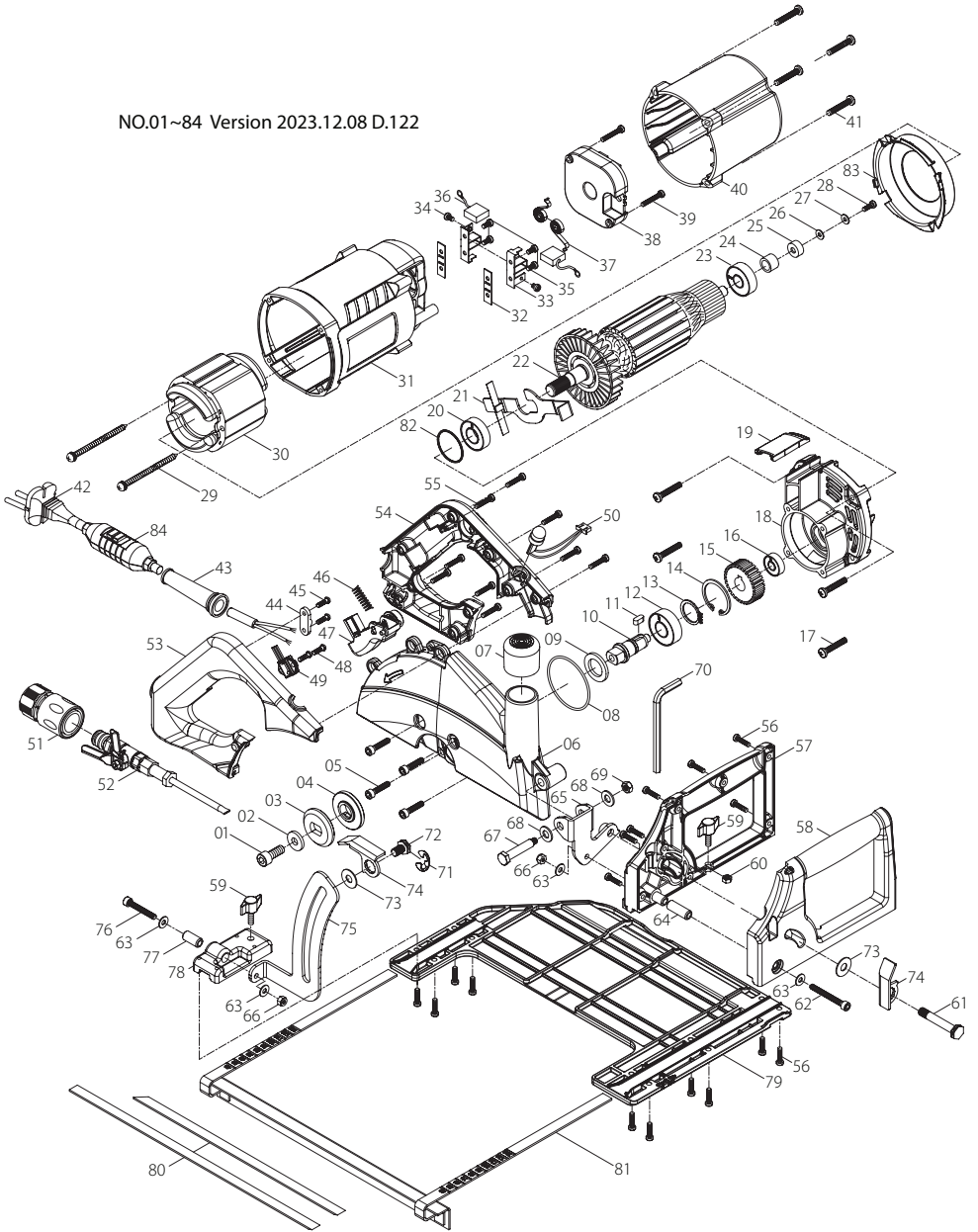

PARTS LIST

NO.	Parts Name	Q'TY	NO.	Parts Name	Q'TY
1	SOCKET CAP SCREW (M8-1.25 x 20)	1	43	CORD ARMOR	1
2	FLAT WASHER (Ø8xØ20x3)	1	44	CABLE CLIP	1
3	OUTER FLANGE	1	45	PANHEAD TAPPING SCREW (M4x14)	2
4	INNER FLANGE (Ø20/Ø25.4)	1	46	SPRING (Ø0.8 x Ø6.4 x Ø8 x 9T x 26L)	1
5	SOCKET CAP SCREW (M5-0.8 x 20)	4	47	SWITCH ACTUATOR (LOCK-OFF)	1
6	BLADE GUARD	1	48	PANHEAD TAPPING SCREW (M4x12)	4
7	END CAP	1	49	HALL EFFECT SWITCH	1
8	O-RING (Ø54x2)	1	50	LED INDICATOR LIGHT	1
9	FELT OILER (Ø19xØ30x3)	1	51	WATER COUPLING (1/2")/(3/4')	1
10	SPINDLE	1	52	WATER FEED CONNECTOR KIT	1
11	PARALLEL KEY (5x5x12)	1	53	HANDLE HALF-RIGHT	1
12	BALL BEARING (6202)	1	54	HANDLE HALF-LEFT	1
13	EXTERNAL CIRCLIP (S-15)	1	55	PANHEAD MACHINE SCREW (M4-0.7 x 20)	9
14	INTERNAL CIRCLIP (R-35)	1	56	PANHEAD MACHINE SCREW (M4-0.7 x 16)	17
15	OUTPUT GEAR (M1.25x30T)	1	57	SIDE HANDLE HALF-REAR	1
16	BALL BEARING (608)	1	58	SIDE HANDLE HALF-FRONT	1
17	PANHEAD MACHINE SCREW (M5-0.8 x 30)	4	59	THUMB SCREW (M5x16)	2
18	GEAR HOUSING	1	60	HEX NUT (M5-0.8)	1
19	COVER PIECE	1	61	ANGLE LOCK PIN (M8x11)	1
20	BALL BEARING (6002)	1	62	SOCKET CAP SCREW (M5-0.8 x 45)	1
21	SPINDLE LOCK	1	63	FLAT WASHER (Ø5xØ12x1)	4
22	ARMATURE(110V/220V-81x46.4x55)	1	64	PIVOT SLEEVE	1
23	BALL BEARING (6200)	1	65	BEVEL BRACKET	1
24	SPACER (Ø8xØ12x10.5)	1	66	NYLOCK NUT (M5-0.8)	2
25	PICKUP MAGNET (Ø8xØ15x5)	1	67	SHOULDER BOLT	1
26	RUBBER WASHER (Ø4xØ11x1)	1	68	FLAT WASHER (Ø8xØ14x1.5)	2
27	FLAT WASHER (Ø4xØ10x1)	1	69	NYLOCK NUT (M6-1.0)	1
28	PANHEAD MACHINE SCREW (M4-0.7 x 10)	1	70	HEX KEY (M6)	1
29	PANHEAD TAPPING SCREW (M5x70)	2	71	E-CLIP (E-10)	1
30	STATOR (110V/220V-81x46.4x55)	1	72	DEPTH LOCK PIN (M8x12)	1
31	MOTOR HOUSING	1	73	FLAT WASHER (Ø8xØ19x1)	2
32	INSULATION PLATE (10x38x1)	2	74	LOCK LEVER	2
33	CARBON BRUSH HOLDER (7x17)	2	75	DEPTH LOCK TRACK	1
34	PANHEAD MACHINE SCREW (M4-0.7 x 6)	2	76	SOCKET CAP SCREW (M5-0.8 x 30)	1
35	PANHEAD TAPPING SCREW (M4x10)	4	77	PIVOT SLEEVE	1
36	CARBON BRUSH (7x17x19)(110V/220V)	2	78	PIVOT BRACKET	1
37	BRUSH SPRING (0.4x4x3T)	2	79	BASE PLATE	1
38	ELECTRONICS UNIT (110V/220V)	1	80	ANTI-FRICTION STRIPS	1
39	PANHEAD TAPPING SCREW (M4x30)	2	81	PARALLEL GUIDE	1
40	TAIL COVER	1	82	O-RING (Ø32x1.5)	1
41	PANHEAD TAPPING SCREW (M5x30)	4	83	FAN BAFFLE	1
42	POWER SUPPLY CABLE	1	84	PRCD INTERRUPTER PROTECTION (110V/220V)	1

WIRING

