

AGP[®]

Electric Beveler

EB6



Instruction Manual

CE CB 



Power Input	1100 W
Voltage	See machine nameplate
No Load Speeds (n ₀)	3000 - 6000 min ⁻¹
Bevel Angle	45° (optional 30°)
Max. Chamfer Height (45°)	6 mm (0.236")
Min. Ø for Inside Bevels	20 mm (0.787")
Weight	4.6 kg (10.1 lb)

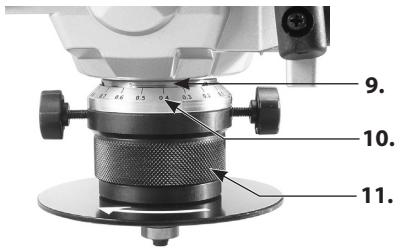
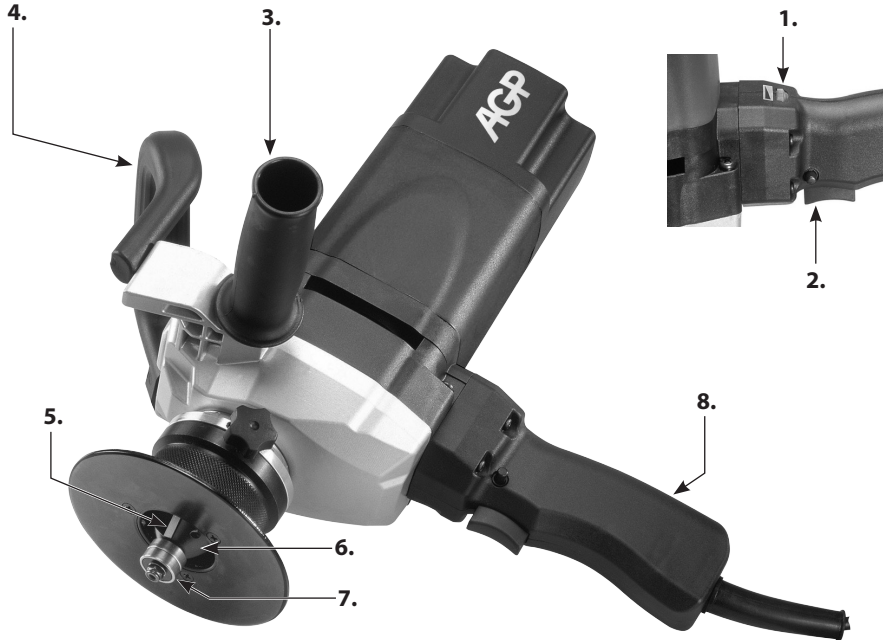

1. Variable speed wheel
2. On/off trigger switch with lock pin
3. Side Handle (Attach to either side)
4. Auxiliary handle
5. Indexable triangle carbide insert
6. Tool holder
7. Impeller
8. Main handle
9. Bevel height scale
10. Adjustable dial ring
11. Support deck

GENERAL SAFETY INSTRUCTIONS



WARNING! Read all safety warnings and all instructions. Failure to follow the warnings and instructions may result in electric shock, fire and/or serious injury.

Save all warnings and instructions for future reference. The term “power tool” in the warnings refers to your mains operated (corded) power tool or battery-operated (cordless) power tool.

1) WORK AREA SAFETY

- a. **Keep work area clean and well lit.** Cluttered or dark areas invite accidents.
- b. **Do not operate power tools in explosive atmospheres, such as in the presence of flammable liquids, gases or dust.** Power tools create sparks which may ignite the dust or fumes.
- c. **Keep children and bystanders away while operating a power tool.** Distractions can cause you to lose control.

2) ELECTRICAL SAFETY

- a. **Power tool plugs must match the outlet. Never modify the plug in any way. Do not use any adapter plugs with earthed (grounded) power tools.**
Unmodified plugs and matching outlets will reduce risk of electric shock.
- b. **Avoid body contact with earthed or grounded surfaces such as pipes, radiators, ranges and refrigerators.** There is an increased risk of electric shock if your body is earthed or grounded.
- c. **Do not expose power tools to rain or wet conditions.** Water entering a power tool will increase the risk of electric shock.
- d. **Do not abuse the cord. Never use the cord for carrying, pulling or unplugging the power tool. Keep cord away from heat, oil, sharp edges or moving parts.** Damaged or entangled cords increase the risk of electric shock.
- e. **When operating a power tool outdoors, use an extension cord suitable for outdoor use.** Use of a cord suitable for outdoor use reduces the risk of electric shock.
- f. **If operating a power tool in a damp location is unavoidable, use an earth leakage circuit breaker.** Use of an earth leakage circuit breaker reduces the risk of electric shock.

3) PERSONAL SAFETY

- a. **a) Stay alert, watch what you are doing and use common sense when operating a power tool. Do not use a power tool while you are tired or under the influence of drugs, alcohol or medication.** A moment of inattention while operating power tools may result in serious personal injury.
- b. **b) Use personal protective equipment. Always wear eye protection.** Protective equipment such as dust mask, non-skid safety shoes, hard hat, or hearing protection used for appropriate conditions will reduce personal injuries.
- c. **Prevent unintentional starting. Ensure the switch is in the off-position before connecting to power source and/or battery pack, picking up or carrying the tool.** Carrying power tools with your finger on the switch or energising power tools that have the switch on invites accidents.
- d. **Remove any adjusting key or wrench before turning the power tool on.** A wrench or a key left attached to a rotating part of the power tool may result in personal injury.
- e. **Do not overreach. Keep proper footing and balance at all times.** This enables better control of the power tool in unexpected situations.
- f. **Dress properly. Do not wear loose clothing or jewelry. Keep your hair, clothing and gloves away from moving parts.** Loose clothes, jewelry or long hair can be caught in moving parts.
- g. **If devices are provided for the connection of dust extraction and collection facilities, ensure these are connected and properly used.** Use of dust collection can reduce dust-related hazards.

4) POWER TOOL USE AND CARE

- a. **Do not force the power tool. Use the correct power tool for your application.** The correct power tool will do the job better and safer at the rate for which it was designed.
- b. **Do not use the power tool if the switch does not turn it on and off.** Any power tool that cannot be controlled with the switch is dangerous and must be repaired.
- c. **Disconnect the plug from the power source and/or the battery pack from the power tool before making any adjustments, changing accessories, or storing power tools.** Such preventive safety measures reduce the risk of starting the power tool accidentally.
- d. **Store idle power tools out of the reach of children and do not allow persons unfamiliar with the power tool or these instructions to operate the power tool.** Power tools are dangerous in the hands of untrained users.
- e. **Maintain power tools. Check for misalignment or binding of moving parts, breakage of parts and any other condition that may affect the power tool's operation. If damaged, have the power tool repaired before use.** Many accidents are caused by poorly maintained power tools.
- f. **Keep cutting tools sharp and clean.** Properly maintained cutting tools with sharp cutting edges are less likely to bind and are easier to control.
- g. **Use the power tool, accessories and tool bits etc., in accordance with these instructions, taking into account the working conditions and the work to be performed.** Use of the power tool for operations different from those intended could result in a hazardous situation.

5) SERVICE

Have your power tool serviced by a qualified repair person using only identical replacement parts. This will ensure that the safety of the power tool is maintained.

Symbols used in this manual

V.....volts

A.....amperes

Hz.....hertz

W.....watt

~.....alternating current

n_0no load speed

min^{-1}revolutions or reciprocation
per minute



.....warning of general danger



.....class II tool



.....read these instructions



.....always wear eye protection



.....always wear a dust mask.



.....always wear hearing protection



.....wear safety-approved hard hat



.....Keep hands clear – pinching hazard.



DANGER! Keep hands away from cutting area and the blade.



rotating parts - entanglement hazard. Keep hands, loose clothing and long hair away from moving parts



do not dispose of electric tools, accessories and packaging together with household waste material

SPECIFIC SAFETY RULES

1. **Never operate** the tool in an area with flammable solids, liquids, or gases. Sparks from the commutator/ carbon brushes could cause a fire or explosion.

**Warning : Risk of injury from high-temperature chips!
High-temperature chips are expelled at high speed.**

Never touch the tool holder and keep all vulnerable body parts clear while the machine is running.

2. **Always guide the machine away from the body while working.**
3. **Do not work holding the machine above your head.**

WARNING! Some dust created by power grinding contains chemicals known to cause cancer, birth defects or other reproductive harm.

An example of these chemicals are:
lead from lead-based paint

Your risk from these exposures varies, depending on how often you do this type of work. To reduce your exposure to these chemicals: work in a well ventilated area, and work with approved safety equipment, such as those dust masks that are specifically designed to filter out microscopic particles.

WARNING!: Never machine materials which contain asbestos.

4. **Use only recommended** carbide inserts, rated at the machine's maximum rated cutting rate or higher.
5. **Do not use dull or damaged** carbide inserts. Dull inserts cause excessive friction and binding and excessive load on the motor, leading to possible damage.
6. **Important: After completing the operation,** Wait for coasting tool holder to stop rotating completely before putting the machine down.
7. **Maintain labels and nameplates.** These carry important information. If unreadable or missing, obtain a replacement.

FUNCTIONAL DESCRIPTION INTENDED USE

This shape beveling and deburring tool is an electrically driven portable machine:

For machining workpieces in steel, chrome steel alloys, aluminum, aluminum alloys, brass and plastic. The machine is designed exclusively for Adding beveled edges, rounding off edges, removing burrs, and removing sharp corners on workpieces. The speed of the machine is variable to suit the needs of various materials and is equipped with a graduated, depth adjustable support deck. It comes with a standard 45 degree tool holder for use with triangle indexable carbide cutter inserts to achieve quick and easy beveling.

WARNING: The machine should not be converted or modified, e.g. for any other form of use, other than as specified in these operating instructions. The user shall be liable for damages and accidents due to incorrect use.

ELECTRICAL CONNECTION

The network voltage must conform to the voltage indicated on the tool name plate. Under no circumstances should the tool be used when the power supply cable is damaged. A damaged cable must be replaced immediately by an authorized Customer Service Center. Do not try to repair the damaged cable yourself. The use of damaged power cables can lead to an electric shock.

EXTENSION CABLE

If an extension cable is required, it must have a sufficient cross-section so as to prevent an excessive drop in voltage or overheating. An excessive drop in voltage reduces the output and can lead to failure of the motor. The following table shows you the correct cable diameter as a function of the cable length for this machine. Use only U.L. and CSA listed extension cables. Never use two extension cables together. Instead, use one long one.

Total Extension Cord Length (feet)	Cord Size (AWG)
25	16
50	12
100	10
150	8
200	6

UNPACKING

Carefully remove the tool and all loose items from the shipping container. Retain all packing materials until after you have inspected and satisfactorily operated the machine.

CARTON CONTENTS

1. Torx Wrench
2. Hook Spanner Wrench
3. Spindle Lock Bar

DO NOT OPERATE THIS TOOL UNTIL YOU READ AND UNDERSTAND THE ENTIRE INSTRUCTION MANUAL.

SETTING THE CHAMFER HEIGHT-DISCONNECT TOOL FROM POWER SOURCE.

1. Loosen the 2 lock knobs
2. Referring to the fixed dial scale and the dial ring on the support deck, turn the entire support deck assembly to set the chamfer height as desired.
3. retighten the 2 lock knobs.

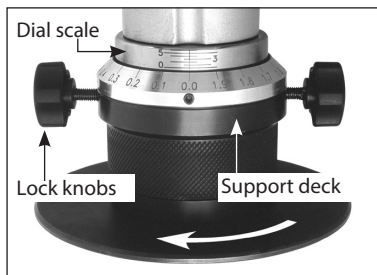

ZEROING-IN THE CHAMFER HEIGHT- DISCONNECT TOOL FROM POWER SOURCE.

Note: The machine's chamfer height is set at zero from the factory. If the setting is disturbed, it must be zeroed in. Follow the instructions below for zeroing-in.

1. Loosen the 2 lock knobs then loosen the support deck assembly so that the inserts are below flush level.
2. Use a steel ruler or other accurate device with a right angle. While keeping the ruler square with the impeller and the support deck, slowly adjust the support deck until the ruler just touches the carbide insert. This is the zero point.

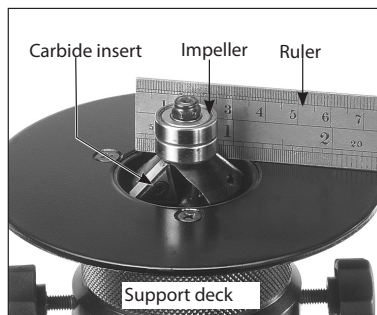

- Once the zero point is found, loosen the small set screw and turn the dial ring to indicate zero on the scale. Then retighten the set screw.

CHANGING THE INDEXABLE CARBIDE INSERTS - DISCONNECT TOOL FROM POWER SOURCE.

WARNING: Danger of Burns! Tool holder and carbide inserts become hot in operation. Wear gloves and take precautions to prevent burns when working with this part of the machine.

Note: indexable carbide inserts have multiple edges. When one edge is dull simply rotate to the next sharp edge. Once all edges are dull, replace with new inserts.

NOTE: Make sure the indexable carbide inserts are installed in the correct direction, incorrect installation of indexable carbide inserts can cause the failure of chamfering or even rupture of the indexable carbide inserts. Please refer to the front of the machine for rotating direction, and install the indexable carbide inserts accordingly.

- Using the supplied L-type torx wrench, Loosen fixing screw and remove the carbide insert.
- Index the carbide insert to the next sharp edge or insert new one as needed.
- Retighten carbide insert with its torx fixing screw.

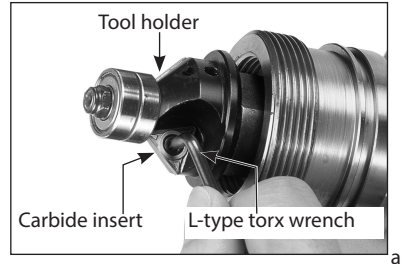

REMOVING THE TOOL HOLDER - DISCONNECT TOOL FROM POWER SOURCE.

WARNING: Danger of Burns! Tool holder and carbide inserts become hot in operation.

Wear gloves and take precautions to prevent burns when working with this part of the machine. If it is necessary to change from the standard 45 deg. Tool holder to an optional 30 deg. Tool holder, the entire tool holder must be changed.

- Loosen the 2 lock knobs and fully unscrew and remove the support deck assembly.
- Using the supplied spindle lock bar, secure the spindle. (You will need to turn the spindle to allow the spindle lock bar to engage).
- Using the supplied hook spanner wrench, engage one of the holes in the tool holder and loosen the tool holder from the spindle.
- Assembly is the reverse of disassembly
- Replace and adjust the support deck assembly.

STARTING AND STOPPING TOOL

Make sure that the power circuit voltage is the same as that shown on the specification plate of the machine and that switch is "OFF" before connecting the tool to the power circuit.

Switching the machine on and off

To switch on:

Press the trigger switch to start.

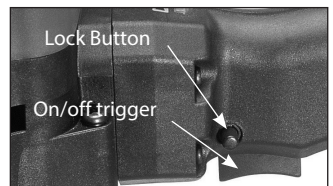

To lock the switch on, press the lock pin next to the switch.

To switch off

Squeeze and release the trigger switch to unlock the switch and switch off.

After the machine has been switched off, the arbor will still rotate for a time. Take care that parts of your body do not come into contact with the rotating parts or set the machine down while it is still rotating!

SPEED CONTROL WHEEL

There is a progressive variable speed wheel. By turning the wheel to the right,, the speed will gradually increase.

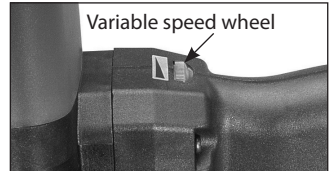

HOW TO USE THE TOOL

- Effective control of this powerful tool requires two-handed operation at all times for maximum control and safety.
- Do not use this tool continuously over 30 minutes.
- Protect your eyes from injury with safety glasses or goggles.

OPERATION

The machine must reach full speed before beveling/deburring begins.

- Hold the machine keeping the support deck flat and securely to the workpiece. From the operator's perspective, the spindle is spinning clockwise, so always operate in the direction from left to right (up mill).
- When performing inside bevels, work in a clockwise direction only.
- Do not bevel more than about 2mm per pass. If more depth is needed, make multiple passes until the desired bevel height is reached

MAINTENANCE

Every 50 hours of operation blow compressed air through the motor while running at no load to clean out accumulated dust. (If operating in especially dusty conditions, perform this operation more often.)

1.Keep tool clean

Periodically blow out all air passages with dry compressed air. All plastic parts should be cleaned with a soft damp cloth. NEVER use solvents to clean plastic parts. They could possibly dissolve or otherwise damage the material.

Wear safety glasses while using compressed air.

2. Lubrication

Every 100 hours of operation, have the gearbox grease replaced by a qualified service technician.

3. Replace the impeller when worn

When the impeller becomes worn the workpiece surfaces will be machined unevenly. Replace when worn as follows:

1. Using the supplied hook spanner wrench, engage one of the holes in the tool holder to immobilize it.
2. Using an appropriate sized wrench loosen the nut securing the impeller and remove.
3. Replacement is the reverse of removal.

THE CARBON BRUSHES

The carbon brushes are a normal wearing part and must be replaced when they reach their wear limit.

Caution: Always replace the brushes as a pair

To replace

First unplug the machine. Carefully remove the 4 screws to separate the rear handle halves and then remove the 4 screws which connect the handle to the motor housing. Lift away the left-hand handle half first. There will still be wires connected to the rear handle, so take care that these are not stressed. Simply hold the rear handle off to one side.

Using pliers, rotate the brush spring out of the way and slide old carbon brush out of the brush holder. Unplug the spade connector to remove the brush lead. The old carbon brush may now be lifted away. Replacing is the reverse of removal. When Replacing the rear handle to the motor housing, take great care that all wires are in place and not in a position to be pinched when it is retightened.

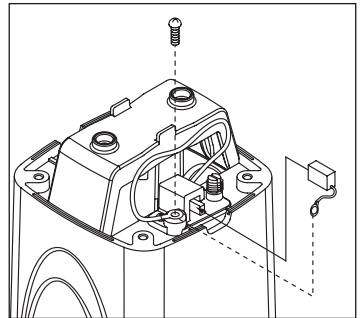

If the replacement of the power supply cord is necessary, this has to be done by the manufacturer or their agent in order to avoid a safety hazard.

WARNING: All repairs must be entrusted to an authorized service center. Incorrectly performed repairs could lead to injury or death.

EXPLODED VIEW

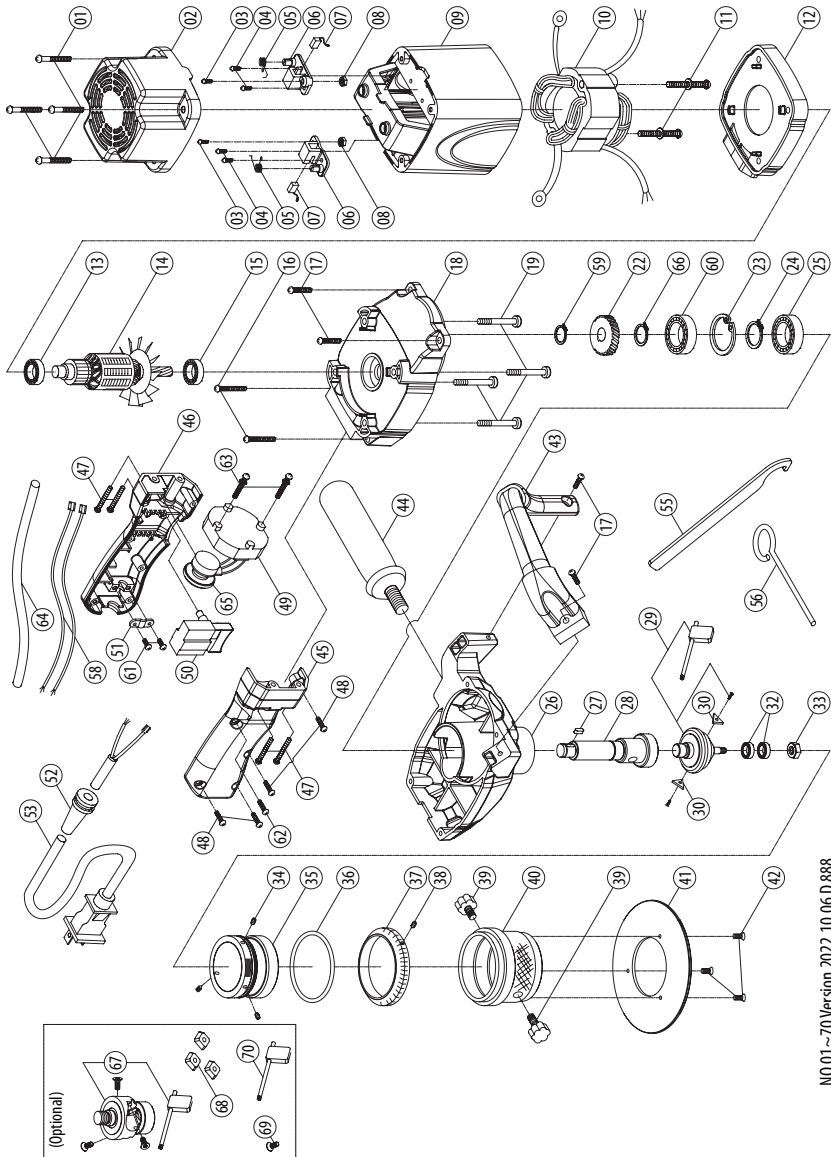

NO.01 ~70 Version 2022.10.06 D.888

PARTS LIST

NO.	Parts Name	Q'TY	NO.	Parts Name	Q'TY
1	PANHEAD TAPPING SCREW-B (M5x25)	4	37	DIAL RING	1
2	MOTOR TAIL CASTING	1	38	SOCKET SET SCREW (M4x4xP0.7)	1
3	PANHEAD MACHINE SCREW (M4x10xP0.7)	2	39	THUMB SCREW (M5x16)	2
4	PANHEAD TAPPING SCREW (M4x12)	4	40	SUPPORT DECK BODY	1
5	BRUSH SPRING (0.35x3x3T)	2	41	SUPPORT DECK PLATE	1
6	CARBON BRUSH HOLDER (7x11)	2	42	FLAT HEAD MACHINE SCREW (M4x10xP0.7)	3
7	CARBON BRUSH (7x11x17)	2	43	AUX. HANDLE	1
8	HEX NUT (M4xP0.7)	2	44	FRONT HANDLE (M12xP1.75)	1
9	MOTOR HOUSING	1	45	HANDLE HALF-RIGHT	1
10	STATOR (110V/220V-73x42x45)	1	46	HANDLE HALF-LEFT (BLACK)	1
11	PANHEAD TAPPING SCREW (M5x60)	2	47	PANHEAD TAPPING SCREW (5/32"x1 1/2")	4
12	FAN BAFFLE	1	48	PANHEAD TAPPING SCREW (M4x20)	4
13	BALL BEARING (608)	1	49	SPEED CONTROL UNIT & EMC (110V/220V)	1
14	ARMATURE (110V/220V-73x42x45)	1	50	TRIGGER SWITCH	1
15	BALL BEARING (6001)	1	51	CABLE CLIP	1
16	PANHEAD MACHINE SCREW (M5x35xP0.8)	2	52	CORD ARMOR	1
17	PANHEAD MACHINE SCREW (M5x20xP0.8)	4	53	POWER SUPPLY CABLE	1
18	GEAR PLATE	1	55	HOOK SPANNER WRENCH	1
19	PANHEAD TAPPING SCREW (M5x40)	4	56	SPINDLE LOCK BAR	1
22	OUTPUT GEAR (M1.0x30T)	1	58	WIRE LEAD (1015-16#50CM)	2
23	INTERNAL CIRCLIP (R-35)	1	59	EXTERNAL CIRCLIP (S-12)	1
24	EXTERNAL CIRCLIP (S-17)	1	60	BALL BEARING (6202)	1
25	BALL BEARING (6003)	1	61	PANHEAD TAPPING SCREW (M4x14)	2
26	GEAR HOUSING	1	62	PANHEAD TAPPING SCREW (M4x16)	1
27	PARALLEL KEY (4x4x10)	1	63	PANHEAD TAPPING SCREW (M4x30)	2
28	SPINDLE (M12xP1.5)	1	64	WIRE SLEEVE (Ø6x20CM)	1
29	TOOL HOLDER (45°C)	1	65	THUMB WHEEL	1
30	INDEXABLE CARBIDE INSERT	2	66	EXTERNAL CIRCLIP (S-15)	1
32	BALL BEARING (626)	2	67	TOOL HOLDER ASSEMBLY (30°)	1
33	NYLOCK NUT (M5xP0.8)	1	68	INDEXABLE CARBIDE INSERT	3
34	SOCKET SET SCREW (M5x6xP0.8)	3	69	TORX FLAT HEAD SOCKET CAP SCREW (M3.5x8xP0.6)	3
35	INNER SUPPORT BARREL	1	70	TORX WRENCH (T15)	1
36	O-RING (3050)	1			

WIRING

