



DM52P

Dry + Wet Diamond Core Drill Motor

Jan. 2025

Internal & Confidential

AGP | DM52P Dry + Wet Diamond Core Drill Motor

AGP TAIWAN

Lee Yeong Industrial Co., Ltd.

No.2, Kejia Rd., Douliu City, 64057, Taiwan

Tel : 886-5-5518689 Fax : 886-5-5518635

AGP EUROPE BV

Evenbroekveld 16D, 9420 Erpe-Mere, Belgium

Tel : +32 53 21 62 22 Fax : +32 53 83 88 20

Introduction

Target group & Applications

DM52P Introduction

The DM52P is a versatile two-speed dry drilling motor with soft percussion. It is designed for efficient dry drilling of brick and similar materials. Its soft percussion keeps the bit's diamond segments sharp and the integrated dust extraction keeps dust flowing out of the kerf. It uses a 1-1/4" spindle for maximum airflow for the vacuum. With the optional M16 Dust Extractor, it can also use M16 banana slot type bits. Although this is primarily a dry drilling motor, with the supplied water supply kit, the tool can also be used for small diameter wet drilling up to 82 mm.

Target Group & Applications

This tool will be suitable for plumbers, HVAC installers, electricians, and anyone who needs to efficiently dry drill in brick and similar materials.



Sales Arguments



1 Integrated Dust Extraction
Collects the dust through the spindle, minimizing dust while cooling the diamond segments.

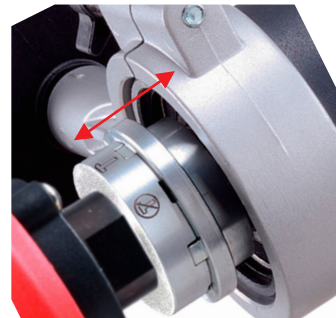

2 Switchable Soft Percussion
keeps the diamond segments sharp for more efficient dry drilling. Can be turned off when not needed.



3 Side Handle
is inline with the spindle for best control.

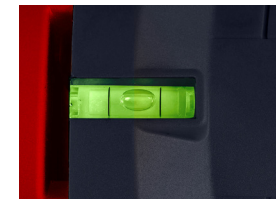

4 Tubular Spirit Level
ensures accurate drilling angle.



Convertible from dry to wet drilling mode with the bayonet mount port on gear case.

Sales Arguments

Optional ADD Quick-Release Dry Drilling Equipment

The ADD system allows for quick and tool-free changing of bits with our special bayonet mount coupling. The large orifice allows maximum airflow. The system includes an extension and a centering pilot.

Optional M16 Dry Drilling Equipment

The M16 Dust Extractor works with banana slot type bits which are favored for socket drilling. Externally ventilated M16 bits can use the M16 adaptor. The system also includes a centering pilot suitable for 85 mm length bits.

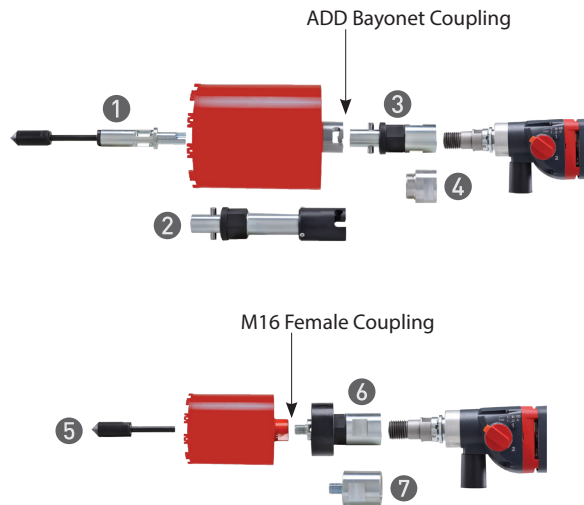

ADD quick release dry drilling equipment			Part Number
①	Centering pilot, ADD		0202-0111-00000-013
②	Extension 200 mm		0299-0114-00000-006
③	ADD quick release		0299-0114-00000-007
④	1-1/4" to ADD M42 Adaptor		301-03022-000-005
Dry Diamond Core Bits with ADD M42 Coupling			Part Number
Diameter(mm)	Coupling	Useful Length(mm)	
56	ADD	200	305-91042-200-056
68	ADD	200	305-91042-200-068
82	ADD	200	305-91042-200-082
102	ADD	200	305-91042-200-102
112	ADD	200	305-91042-200-112
132	ADD	200	305-91042-200-132
162	ADD	200	305-91042-200-162
172	ADD	200	305-91042-200-172
182	ADD	200	305-91042-200-182
M16 dry drilling equipment			Part Number
⑤	Centering Pilot		0202-0111-00000-008
⑥	M16 Dust Extractor (for banana slot bits)		0299-0114-00000-008
⑦	1-1/4" to M16 Adaptor		301-03022-000-005
Dry Diamond Core Bits with M16 Coupling			Part Number
Diameter(mm)	Coupling	Useful Length(mm)	
68	M16	85	305-91016-085-068
82	M16	85	305-91016-085-082
102	M16	85	305-91016-085-102
112	M16	85	305-91016-085-112

Technical Specifications

Model	DM52P
Power Input	1800 W
Voltage	110-120 V~ 50-60 Hz or 220-240 V~ 50-60 Hz
No Load (Rated Load) Speed	Speed 1 : 1800 (1080) min ⁻¹ Speed 2 : 3600 (2160) min ⁻¹
Percussion Frequency, No Load (Rated Load)	Speed 1 : 29 000 b/min (18 850 b/min) Speed 2 : 56 000 b/min (36 400 b/min)
Arbor Thread	1-1/4" UNC male & 1/2" BSP female
Capacity-Dry	182 mm (7-1/4")
Capacity-Wet	82 mm (3-1/4")
Dimensions (LxWxH)	450 x 105 x 280 mm
Neck Diameter	60 mm
Weight	4.9 kg

- 1 Side Handle
- 2 Lock Screw (Side Handle)
- 3 Release Button
- 4 Tubular Spirit Level
- 5 Spindle
- 6 Percussion Selector
- 7 Gear Selector
- 8 Motor
- 9 Trigger Switch
- 10 Main Handle
- 11 Lock Button
- 12 Power Supply Cable
- 13 Bayonet Mount Port
- 14 Vacuum Adapter Head
- 15 Water Feed Adapter Head
- 16 Hammer Symbol (Percussion On)
- 17 No Hammer Symbol (Percussion Off)

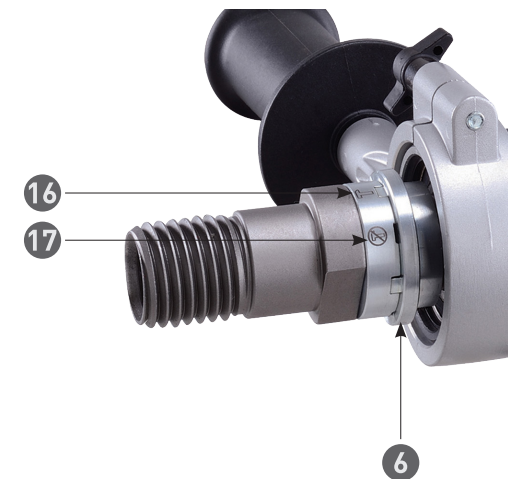

Ideal Operating Window

Dry Drilling in Brick

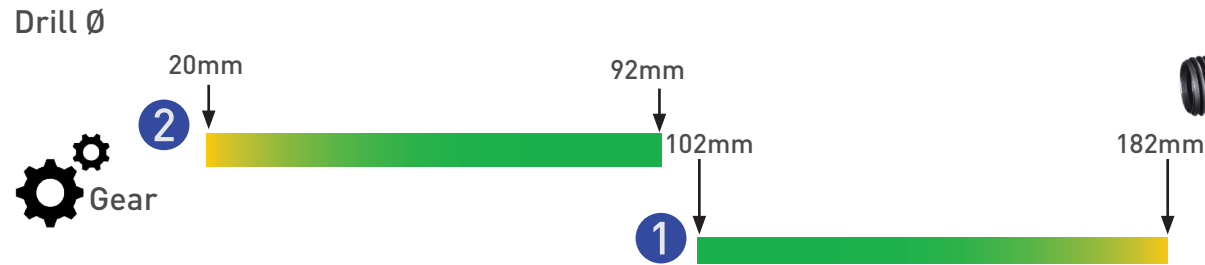

Wet Drilling in Reinforced Concrete

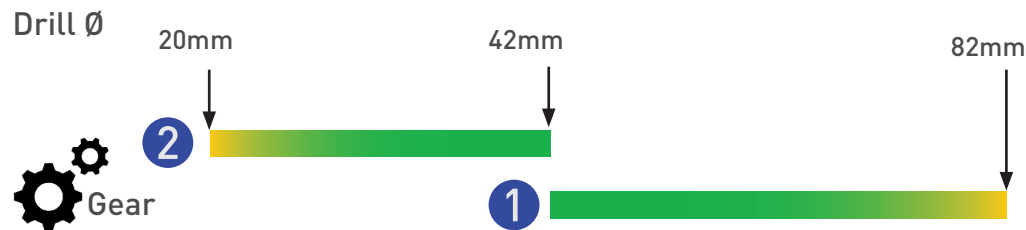

Offer Content

Standard Accessories

- ① DM52P Dry Diamond Core Drill Motor
- ② Side Handle
- ③ Vacuum Adapter Head
- ④ Water Feed Adapter Head
- ⑤ Blow Molded Case

Optional Accessories

- ⑥ Soft Grip Side Handle
- ⑦ Vacuum Collector Pad (Small up to 75 mm)
- ⑧ Vacuum Collector Pad (large up to 130 mm)
- ⑨ M16 Dry Drilling Equipment
- ⑩ ADD Quick-Release Dry Drilling Equipment
- ⑪ SDS Pilot Drill Socket



Comparison Table

Brand

AGP

AEG

Milwaukee

BAIER
Elektro-
werkzeuge

EIBENSTOCK

CARDI

General Dry Drilling in Brick



Model	DM52P	DB1500-2XE	DD2-160XE	BDB 823 A	EHD 2000 S	P 2000 MS13
Power	220-240 V: 1800 W	220-240 V: 1510 W	220-240 V: 1510 W	220-240 V: 1800 W	220-240 V: 1700 W	220-240 V: 2000 W
RPM (rated load)	Gear 1: 1080 /min Gear 2: 2160 /min	Gear 1: 0~890 /min Gear 2: 0~1770 /min	Gear 1: 0~890 /min Gear 2: 0~1770 /min	1650 /min	Gear 1: 0~1000 /min Gear 2: 0~2000 /min	1350 /min
Percussion Frequency (rated load)	Gear 1: 18 850 b/min Gear 2: 36 400 b/min	Gear 1: 24 000 bpm Gear 2: 48 000 bpm	Gear 1: 24 000 b/min Gear 2: 48 000 b/min	33 000 b/min	N/A	34 000 b/min
Capacity-Dry	182 mm	162 mm	162 mm	150 mm	132 mm	162 mm
Capacity-Wet	82 mm	N/A	N/A	N/A	N/A	N/A
Spindle	1-1/4" UNC male & 1/2" BSP female	M18-2.5	M18-2.5	M18-2.5	M18-2.5	M18-2.5
Switchable Percussion	YES	YES	YES	YES	NO	YES
2 Speed Gearbox	YES	YES	YES	NO	YES	NO
Blowcase	YES	YES	YES	YES	YES	YES
Anti-Vibration Side Handle	Optional	YES	YES	NO	NO	NO
Built-in Level	YES	NO	NO	YES	NO	NO
Variable Speed Switch	NO	YES	YES	NO	YES	NO
Weight	5 kg	4.2 kg	4.2 kg	5.2 kg	5.5 kg	4.8 kg
Dust Collector Description	For 1-1/4" thread unventilated bits	Not Available	For 1-1/4" thread, unventilated bits only. No limitation on length.	For M16 thread, short socket bits with side vents only.	For M16 thread, short socket bits with banana slot vents only, 1-1/4" bits not limited on length.	For 1-1/4" thread, unventilated bits only. No M16 dust collector sold.
Centering Aid	Optional	Not Available	Optional	Optional	Optional	Optional
Dust Collector	Integrated	Not Available	M18- 1-1/4"	M18-M16	M18-M16 M18- 1-1/4"	M18- 1-1/4"
Conclusion	The AGP brings together all the features for the ideal dry drill, with the power, percussion, ideal rpm, and level to allow optimal drilling. The AGP 1-1/4" spindle allows better air flow for superior dust extraction. It is the only tool here with additional water feed function for occasional wet drilling. The AGP provides the best function and value in this segment.					

AGP | DM52P Dry + Wet Diamond Core Drill Motor

Tool Dimensions