



NS250 Drill Stand

Dec. 2023

Internal & Confidential

AGP TAIWAN

Lee Yeong Industrial Co., Ltd.
No.2, Kejia Rd., Douliu City, 64057, Taiwan
Tel : 886-5-5518689 Fax : 886-5-5518635

AGP EUROPE BV

Evenbroekveld 16D, 9420 Erpe-Mere, Belgium
Tel : +32 53 21 62 22 Fax : +32 53 83 88 20



Sales Arguments

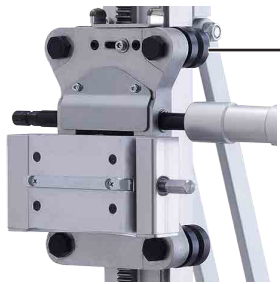

Roller Carriage Guidance
V-groove type low-friction and zero backlash roller guidance with eccentric adjustment.



Large Drilling Capacity
Fits 250 mm bits in stock form, without needing to use any extension spacers.



Steel Box Section Base
The heavy duty steel base gives reliable stability with large diameters.



Steel-Reinforced Aluminum Column
Only the wearing surfaces, (the gear rack and roller tracks) are steel, for maximum strength and manageable weight.



M12 Control Elements
For the convenience of the operator, all control elements on the stand are M12 head, and the crank handle can also be used as a wrench for these.



Technical Specifications

Model	NS250
Capacity (without spacers)	250 mm
Effective Stroke (mm)	660 mm
Dimensions (LxWxH)	400 x 245 x 984 mm
Weight	14.9 kg

- 1 Column
- 2 Carriage Lock
- 3 Carriage
- 4 Motor Mount
- 5 Leveling Screws
- 6 Steel Base
- 7 Buttress Bars
- 8 Guide Roller
- 9 Cradle Lock
- 10 Crank Spindle
- 11 Tilt Lock
- 12 Handle
- 13 Tilt Scale

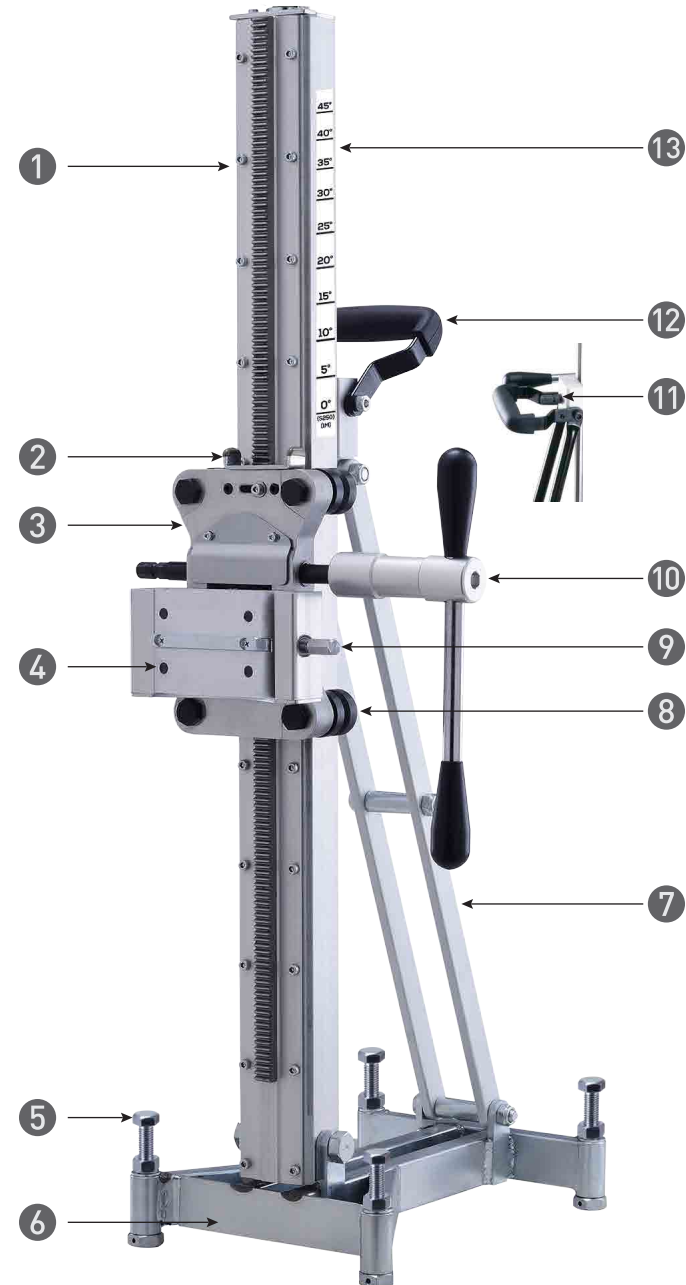

Offer Content

Standard Accessories













- ① S250 Drill Stand
- ② Crank Handle, 2 spoke sliding
- ③ Motor Mount, 4 bolt
- ④ M19 Open End Wrench

Optional Accessory















- ⑤ 40 mm Spacer Kit
- ⑥ 60 mm Clamp Bracket (for hand-held motors)
- ⑦ Anchoring Plate
- ⑧ Laser Aiming Device, 1/2" BSP
- ⑨ Laser Aiming Device, 1-1/4" & Ø 60 mm
- ⑩ VP140 Vacuum Pump
- ⑪ VB400 Vacuum Plate
- ⑫ Vacuum Tank
- ⑬ Fixing Kit, M12 anchors
- ⑭ Jack Screw



Comparison Table

Brand						
250 mm Drill Stands						
Model	NS250	DRA 250	KF 250	L250	DS 250	BST 250
Capacity Ø (without spacers)	250 mm	250 mm	250 mm	250 mm	250 mm	250 mm
Stroke	660 mm (usable stroke)	600 mm	590 mm	702 mm	686 mm	not listed
Tilt Angle	0°- 45°	0°- 45°	60° front and back	0°- 45°	0°- 60°	0°- 45°
Motor Mount	dovetail type	Tyrolit ModulDrill quick-release	quick-release type	Cardi Rapid Lock6	dovetail type	dovetail type
Carriage	4 rollers (w/ eccentric adjustment)	4 rollers (w/ eccentric adjustment)	4 stainless rollers	sliding pads	4 rollers (w/ eccentric adjustment)	sliding pads
Buttress Bars	aluminum (2), braced	steel (2)	optional	steel (2)	aluminum, rectangular (1)	steel (2)
Feed Handle	2 spoke sliding, multipurpose, M12	4 spoke sliding (not multipurpose)	3 spoke, square drive	2 spoke sliding, multipurpose, M19	2 spoke multipurpose, w/ springs	2 spoke sliding, multipurpose, D coupler
Crank Gearing	1:1 on both sides	1:1 on one side, 3.5:1 on the other	1:1 on both sides	1:1 on both sides	1:1 both sides, 2:1 one side	1:1 both sides
Functional Fastener Size	all M12 head	all M19 head	mix of square drive and M19 head	all M19 head	all M17 head	special D couplers
Base	anchor type, steel	anchor type, steel	anchor type, steel	anchor type, aluminum	combination type, aluminum	anchor type, aluminum

Comparison Table

Brand						
250 mm Drill Stands						
Model	NS250	DRA 250	KF 250	L250	DS 250	BST 250
Leveling Screws	19 mm hex head (4)	19 mm hex head (4)	tool-free type (4)	19 mm hex head (4)	17 mm hex head (4)	tommy bar type (4)
Column	aluminum, steel reinforced	aluminum	stainless steel	steel	aluminum	aluminum
Spirit Levels	no	no	no	2	no	2
Carry Handle	yes	 yes	yes	no	yes	no
Vacuum Base Compatible	yes (separate vacuum plate)	 no	no	yes (separate vacuum plate)	combination type base	yes (separate vacuum plate)
Water Collector Compatible	yes	yes	yes	yes	yes	no
Wheels	no	no	optional	yes	optional	optional
Weight	14.9 kg	14.0 kg	16.0 kg	16.3 kg	17.0 kg	15.5 kg
Dimensions L x W x H	400 x 245 x 984 mm	350 x 205 x 933 mm	330 x 200 x 950 mm	440 x 260 x 1000 mm	545 x 266 x 1052 mm	430 x 330 x 995 mm
Street Price, EU w/o tax		908,75 €	1157,32 €	638,36 €	1023,80 €	673,32 €
Conclusion	<p>The AGP NS250 is specifically designed for rig-mount type drill motors up to 250 mm, and is also suitable for hand-held motors with an optional clamp bracket. The AGP uses the superior roller carriage system, rather than the sliding pad type. The carriage system is adjustable to always ensure stability and precision. The more common sliding pad system is less stable and less precise. For convenience, all the operative elements of the stand are the same head size, and the crank handle can be used as a wrench for these. The AGP has braced buttress bars for additional stability and use of aluminum is maximized for manageable weight while using steel when necessary, such as in the base, to provide optimal strength. The AGP is clearly an excellent choice for drilling up to 250 mm.</p>					

Tool Dimensions (mm)

