



C16 Concrete saw

May. 2024

Internal & Confidential

AGP | C16 Concrete Saw

AGP TAIWAN

Lee Yeong Industrial Co., Ltd.

No.2, Kejia Rd., Douliu City, 64057, Taiwan

Tel : 886-5-5518689 Fax : 886-5-5518635

AGP EUROPE BV

Evenbroekveld 16D, 9420 Erpe-Mere, Belgium

Tel : +32 53 21 62 22 Fax : +32 53 83 88 20



Introduction

Target group & Applications

Introduction & Target Group

This saw is an indispensable tool for concrete cutters, construction professionals, or anyone who needs to cut reinforced concrete, especially indoors. Its 3200 W motor provides the power for the fastest possible cutting and its electronic controls grant excellent performance, motor protection, and operator useability. It incorporates a variety of useful features to maximize work efficiency.

Applications

This saw is a concrete cutter's go-to tool, being the fastest and most economical solution in most situations. It uses a 16" blade for up to 150 mm depth of cut. With the required flange and blade, it is also capable of flush cutting. The tool can perform wet cutting as well as dry cutting and can use the highly effective dust skid.

Being electric, this tool is essential for any indoor cutting applications, especially in basements, where the more common petrol cutters are strictly not allowed. Another big advantage of electric over petrol is for applications when the saw is needed to make a series of quick cuts, with other work needed to be done in between each cut. In such conditions, it's very inconvenient to be restarting the petrol engine each time another cut is needed.

The C16 is the essential tool in any concrete cutter's arsenal.



Sales Arguments



LED Load Indicator

Allows the operator to maintain maximum work efficiency. The motor features overload and overheat protection.



Flush Cut Capability (optional)

Special design allows very close to flush cutting



Waterproof Hall Effect Switch

Is impervious to dust or water



Guide Rollers

Allow perpendicular cuts while reducing operator fatigue. They are tool-free detachable.

Sales Arguments



Dust Skid (optional)

Allows excellent dust control for dry cutting



Integrated Water Feed System

With fine adjustable flow and quick release coupling.



Splash Guard

The spring-loaded splash guard and brush follow the work surface. They are tool-free detachable for flush cutting.



Toggle Latches

Allow tool-free removal of the outer blade guard for quick conversion to flush cutting.

Technical Specifications



Model	C16
Power Input	3200 W (230-240 V), 3000 W (220 V), 2800 W (110-120 V)
Voltage, Frequency	220~240 V~ 50-60 Hz or 110~120 V~ 50-60 Hz
No Load Speed	3900 min ⁻¹
Linear speed with 16"blade	82.7 m/s (no load), 53.9 m/s (rated)
Blade Diameter	406 mm (16")
Arbor	25.4 mm (1")
Max. Cutting Depth	150 mm (6")
Insulation Class	Class I, (220-240 V models with PRCD / GFCI)
Dimensions (LxWxH)	660 x 259 x 280 mm
Weight	9.6 kg (21.1 lb), 10 kg (22.2 lb) with guide rollers

Offer Content

Standard Accessories

- ① C16 Concrete Saw
- ② M3 L-hex wrench
- ③ M17 Combination Wrench
- ④ PRCD / GFCI Interruptor (220-240 V models only)







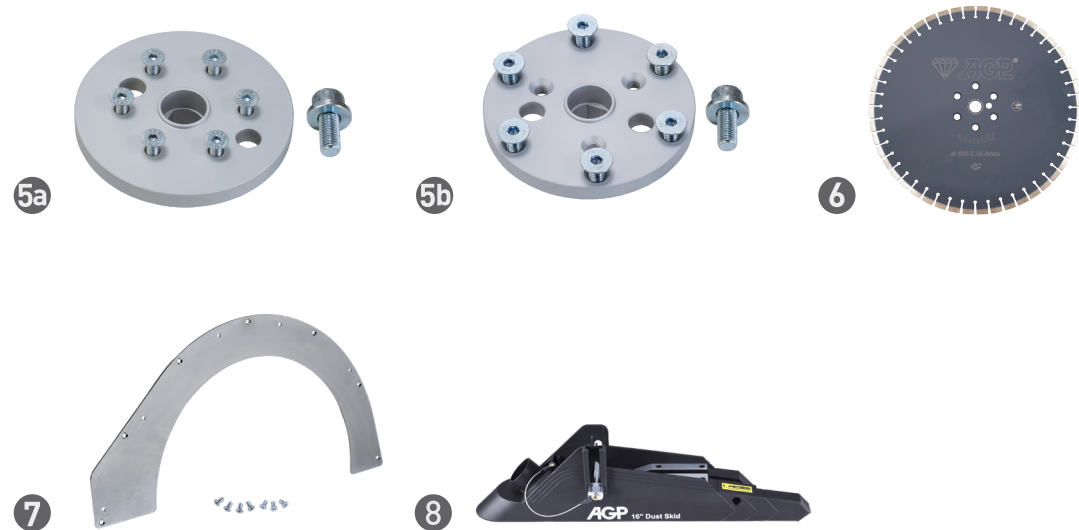











Optional Accessories

- ⑤a Flush Cutting Flange Kit - 60 mm bolt hole circle
- ⑤b Flush Cutting Flange Kit - 88.9 mm bolt hole circle + 3-bolt
- ⑥ 406 mm Flush Cutting Blade (88.9 mm bolt hole circle)
- ⑦ Flush Cut Cover Set
- ⑧ Dust Skid 16"



Comparison Table

Brand					
					
Model	C16	TP 400	PE 401	ETR 400.1 P	4114S (modified)
Power Input	3200 W (230 V)	3000 W (230 V)	3420 W (230 V)	2850 W (230 V)	2400 W (230V)
Blade Diameter	406 mm (16")	405 mm (16")	405 mm (16")	400 mm (16")	405 mm (355 mm originally)
No Load RPM	3900 min ⁻¹	2530 min ⁻¹	2870 min ⁻¹	3000 min ⁻¹	3500 min ⁻¹
Linear speed with 16" blade	82.7 m/s	53.6 m/s	60.8 m/s	63.6 m/s	74.2 m/s
Max. Cutting Depth	150 mm	160 mm	135 mm (160 mm w/o dust skid)	152 mm	150 mm
Blade Direction	Clockwise (down cut)	Clockwise (down cut)	Clockwise (down cut)	Anticlockwise (up cut)	Clockwise (down cut)
Waterproof / Dustproof Switch	Yes, Hall-Effect Type 	No, (traditional type)	No, (traditional type)	No, (traditional type)	No, (traditional type)
Weight (w/o blade)	9.1 kg (9.6 kg w/guide rollers)	11 kg	14.5 kg	13.4 kg	Around 12.2 kg (with flush cutting blade guard)
Blade Guard Material	Aluminum	Aluminum	Aluminum & Steel	Aluminum & Steel	Steel
LED Load Indicator	Yes 	No	No	Yes	No
Guide Rollers	Yes, standard (does not effect cutting capacity) 	Yes	Yes	Yes	No
Spring-Loaded Splash Guard and removable brush	Yes 	No, rigid splash guard (gives poor protection)	No	No	No, rubber flap
Vacuum port for dry cutting	Yes	No	Yes	Yes	Yes
Dry Cutting Dust Skid	Optional 	No	Yes	No	No
Flush Cut Capable	Optional 	Optional	Standard	Optional	Optional (aftermarket)

Comparison Table

Brand					
					
Model	C16	TP 400	PE 401	ETR 400.1 P	4114S (modified)
Flush Cut Bolt Hole Pattern	3 types available: 1" Longyear,  Cardi 3-bolt, 60mm 6-bolt	Cardi 3-bolt	Cardi 3-bolt	60mm 6 bolt	60mm 6 bolt
Flush cut quick-change blade guard system	Yes as standard 	No	No	No	Optional (aftermarket)
Water Feed	Yes (Both sides), Maintenance free	Yes (spindle mounted - water seals require periodic replacement)	Yes (spindle mounted - water seals require periodic replacement)	Yes (central)	Yes-(one side only)
PRCD	Yes (but no PRCD in 110V)	Yes	Yes	Yes	Yes
Street Price w/o tax (as of 2022.05)		1,153.57 €	1,915.50 €	1,146.84 €	507.45 € (+ aftermarket guard)

Conclusion

The **AGP C16** is a unique product which combines good design, excellent power, higher rpm and light weight. Its features, convenience and excellent price make it the ideal choice for a 16" concrete saw with flush cutting capability. It has all the excellent features of the C14, plus the addition of flush cutting capability. Once set up, the C16 flush cutting system allows fast conversion between standard and flush cutting modes.

The **Cardi** is heavier, less convenient, more expensive and doesn't have the features of the C16 like load warning lamp. Its lower rpm results in slower cutting. Although it has 10mm extra cutting depth, this comes at the cost of using a transverse motor orientation, which makes the saw unwieldy, wide and unbalanced. There is no possibility of quickly changing between standard and flush cutting. Each time you must loosen and tighten 5 screws. A drawback of the TP400 is the rigid splash guard, which at any angle other than tail down, will throw slurry back at the operator. The spindle mounted water feed system is a maintenance issue because the water seals will require frequent replacement. If they leak, water could enter its gearbox.

The **Makita** is a vendor-modified unit based on a 14" saw. It is heavier, severely underpowered and doesn't have the features of the **AGP C16** like guide wheels, load warning lamp, or dry cutting dust extraction.

The **AGP C16** provides the best performance, features, and value in this segment.

Tool Dimensions

