

AGP®



C14 Concrete saw

May. 2024

Internal & Confidential

AGP | C14 Concrete Saw

AGP TAIWAN

Lee Yeong Industrial Co., Ltd.

No.2, Kejia Rd., Douliu City, 64057, Taiwan

Tel : 886-5-5518689 Fax : 886-5-5518635

AGP EUROPE BV

Evenbroekveld 16D, 9420 Erpe-Mere, Belgium

Tel : +32 53 21 62 22 Fax : +32 53 83 88 20



Introduction

Target group & Applications

Introduction & Target Group

This saw is an indispensable tool for concrete cutters, construction professionals, or anyone who needs to cut reinforced concrete, especially indoors. Its 3000 W motor provides the power for the fastest possible cutting and its electronic controls grant excellent performance, motor protection, and operator usability. It incorporates a variety of useful features to maximize work efficiency.

Applications

This saw is a concrete cutter's go-to tool, being the fastest and most economical solution in most situations. It uses economical and readily available 14" blades for up to 125 mm depth of cut. The tool can perform wet cutting as well as dry cutting and can use the highly effective dust skid.

Being electric, this tool is essential for any indoor cutting applications, especially in basements, where the more common petrol cutters are strictly not allowed. Another big advantage of electric over petrol is for applications when the saw is needed to make a series of quick cuts, with other work needed to be done in between each cut. In such conditions, it's very inconvenient to be restarting the petrol engine each time another cut is needed.

The C14 is the essential tool in any concrete cutter's arsenal.



Sales Arguments



LED Load Indicator

Allows the operator to maintain maximum work efficiency. The motor features overload and overheat protection.



Dust Skid (optional)

Allows excellent dust control for dry cutting



Waterproof Hall Effect Switch

Is impervious to dust or water



Splash Guard

The spring-loaded splash guard and brush follow the work surface. They are tool-free detachable for flush cutting.



Guide Rollers

Allow perpendicular cuts while reducing operator fatigue. They are tool-free detachable.

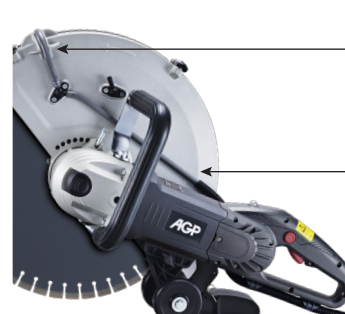

Integrated Water Feed System

With fine adjustable flow and quick release coupling.

Technical Specifications



Model	C14
Power Input	3000 W (230-240 V), 2800 W (220 V), 2300 W (110-120 V)
Voltage, Frequency	230~240 V~ 50-60 Hz or 220 V~ 50-60 Hz or 110~120 V~ 50-60 Hz
No Load Speed	4500 min ⁻¹
Linear speed with 16"blade	83.6 m/s (no load), 54.3 m/s (rated)
Blade Diameter	355 mm (14")
Arbor	25.4 mm (1")
Max. Cutting Depth	125 mm (5")
Insulation Class	Class I, (220-240 V models with PRCD / GFCI)
Dimensions (LxWxH)	611 x 245 x 280 mm
Weight	7.9 kg (17 lb), 8.3 kg (18 lb) with guide rollers

Offer Content

Standard Accessories

- ① C16 Concrete Saw
- ② M17 Combination Wrench
- ③ PRCD / GFCI Interruptor



















Optional Accessories

- ④ 355 mm (14") Diamond Blade
- ⑤ Dust Skid 14"



Comparison Table

Brand									
Model Number	C14	K4000	PE 350	DRS HS-351	4114	CM12Y	ETR 350.1 P	DCH 300 X	PCD-3060
Blade Diameter	355 mm (14")	355 mm (14")	355 mm (14")	355 mm (14")	355 mm (14")	305 mm (12")	355 mm (14")	305 mm (12")	255 mm (10")
Power Input	2 800 W	2 700 W	3 000 W	2 200 W	2 400 W	2 400 W	2 700 W	2 600 W	1 430 W
Depth of Cut	125 mm	125 mm (119 mm w/ dust shoe)	140 mm	140 mm	125 mm	100 mm	130 mm	120 mm	75 mm
No Load Speed	4 500 /min	3 900 /min	3 250 /min	3 800 /min	3 500 /min	5 000 /min	2 200 /min	4 900 /min	4 500 /min
Weight (w/o blade)	7,9 kg (8,3 kg w/guide rollers)	7,6 kg	11,5 kg	9,8 kg	10,8 kg	11,5 kg	12,9 kg	9,4 kg	9,6 kg
Cutting Direction	Down Cut	Down Cut	Down Cut	Down Cut	Down Cut	Down Cut	Up Cut	Up Cut	Down Cut
Waterproof / Dustproof Switch	Yes, Hall-Effect Type 	No (traditional type)	No (traditional type)	No (traditional type)	No (traditional type)	No (traditional type)	No (traditional type)	No (traditional type)	No (traditional type)
LED Overload Indicator	Yes 	No	No	No	No	No	Yes	No	No
Adjustable Blade Guard Angle	Yes 	Yes	No (adjustable depth)	No (adjustable depth)	No	Yes	Yes	Yes	Yes
Guide Rollers	Yes 	No	Yes	No	No	No	Yes	Yes	Yes
Splash Guard	Yes 	Yes	No	No	No	No	No	No	No
Slurry Control Brush	Yes 	No	No	No	No	No	No	No	No
Vacuum Port for Dust Collection	Yes 	No	No	No	Yes	Yes	Yes	Yes	No
Dust Skid	Optional	Optional	No	No	No	No	No	No	No
Water Feed	Yes	Yes	Yes	Yes (w/ flow indicator)	No	No	No	Yes	No
PRCD	Yes	Yes	Yes	Yes	No	No	No	No	No
Conclusion	<p>The AGP C14 has a more powerful motor & has larger module (more robust) gear design than the Husqvarna K4000. It also has many important features which are missing on the K4000 & others, such as the guide rollers, LED load warning lamp, and combined wet and dry capability in one tool-at no extra cost.</p> <p>Comparing to the AGP C14, the Makita and Hitachi are completely outclassed. They are an old-style, clumsy, heavy design with no water feed which does not have the cutting versatility of the others.</p> <p>The Makita's lower rpm and lower power make it cut much more slowly. While the Eibenstock, despite having adequate power, will also cut very slowly due to its very low RPM. The Hikoki and Hilti are limited by their 305mm blade, with the Ryobi even more limited by its 255 mm blade.</p> <p>The AGP C14 is the obvious best choice.</p>								

Tool Dimensions

